

## 5. MAINTENANCE CHART

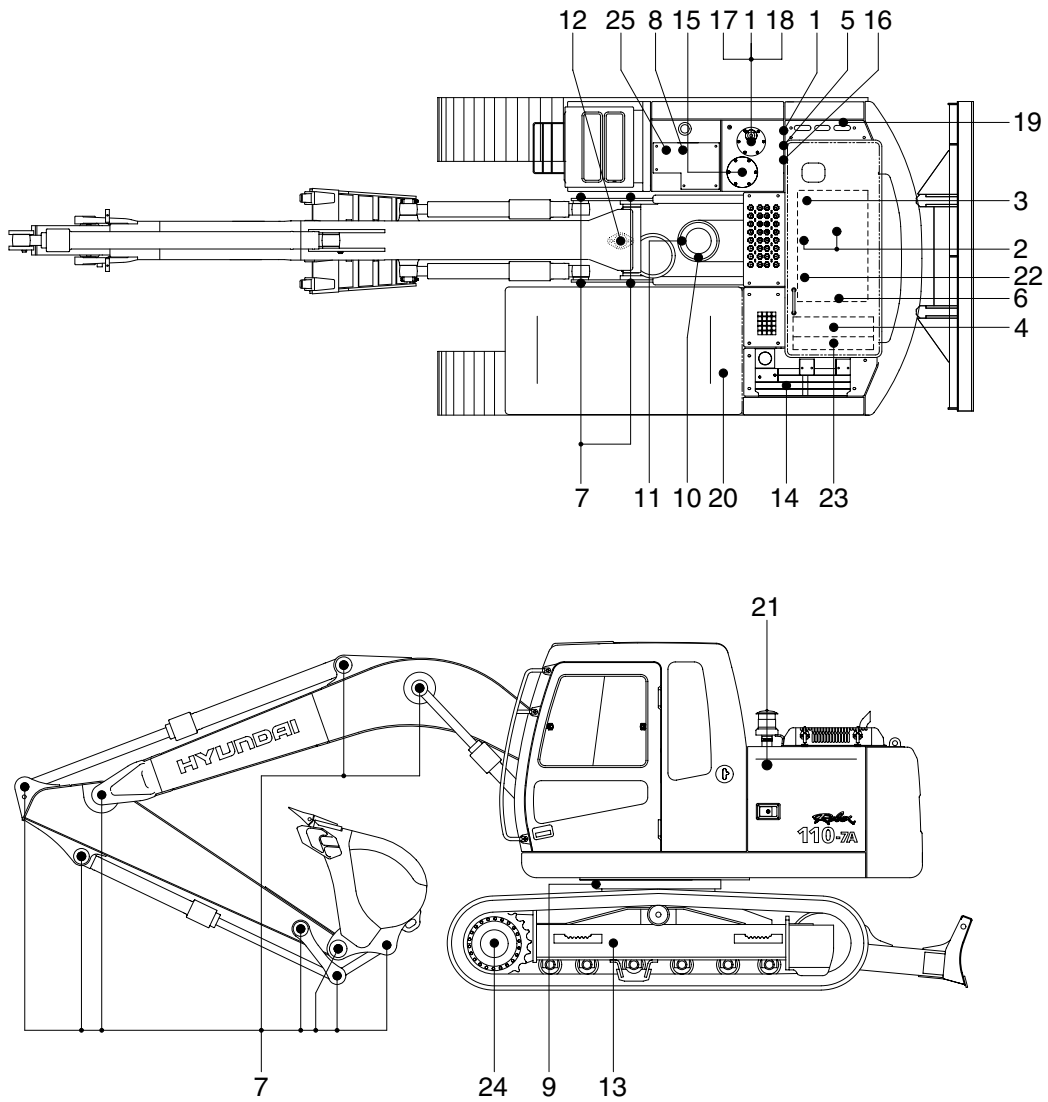

1107A6MA05

### Caution

1. Service intervals are based on the hour meter reading.
2. The number of each item shows the lubrication point on the machine.
3. Stop engine while filling oil, and use no open flames.
4. For other details, refer to the service manual.

Service interval	No.	Description	Service action	Oil symbol	Capacity l (U.S.gal)	Service points No.
10 Hours or daily	1	Hydraulic oil level	Check, Add	HO	100(26.4)	1
	2	Engine oil level	Check, Add	EO	18.5(4.9)	1
	4	Radiator coolant	Check, Add	C	22(5.8)	1
	5	Prefilter(water, element)	Check, Clean	-	-	1
	6	Fan belt tension & damage	Check, Adjust	-	-	1
	25	Fuel tank oil	Check, Refill	DF	256(67.6)	1
50 Hours or weekly	7	Attachment pins & chamber	Check, Add	PGL	-	17
	8	Fuel tank (water, sediment)	Check, Clean	-	-	1
	9	Swing bearing grease	Check, Add	PGL	-	3
	10	Swing reduction gear case	Check, Add	GO	2.5(0.66)	1
	13	Track tension	Check, Adjust	PGL	-	2
250 Hours	14	Battery(electrolyte)	Check, Add	-	-	2
	17	Air breather element	Replace	-	-	1
	20	Aircon & heater flesh filler	Check, Clean	-	-	1
500 Hours	2	Engine oil	Change	EO	18.5(4.9)	1
	3	Engine oil filter	Replace	-	-	1
	5	Prefilter	Replace	-	-	1
	21	Air cleaner element(primary)	Clean	-	-	1
	22	Fuel filter element	Replace	-	-	1
	23	Radiator, Oil cooler, Charge air cooler	Clean	-	-	3
1000 Hours	10	Swing reduction gear case	Change	GO	2.5(0.66)	1
	12	Swing gear and pinion grease	Change	PGL	4.0kg(8.7lb)	1
	15	Hydraulic oil return filter	Replace	-	-	1
	16	Drain filter cartridge	Replace	-	-	1
	19	Pilot line filter element	Replace	-	-	1
	24	Travel reduction gear case	Change	GO	2.5(0.66)	2
2000 Hours	1	Hydraulic oil	Change	HO	100(26.4)	1
	4	Radiator coolant	Change	C	22(5.8)	1
	18	Hydraulic oil suction strainer	Check, Clean	-	-	1
As required	20	Aircon & heater recirculation filter	Clean, Replace	-	-	1
	20	Aircon & heater fresh filter	Replace	-	-	1
	21	Air cleaner element(safety)	Replace	-	-	1
	21	Air cleaner element(primary)	Replace	-	-	1

※ **Oil symbol**

Please refer to the recommended lubricants for specification.

DF : Diesel fuel    PGL : Grease    C : Coolant

HO : Hydraulic oil    GO : Gear oil    EO : Engine oil