

2. DIMENSION AND WEIGHT

1) ROBEX 110-7

(1) Base machine

Mark	Description	Unit	Specification
L	Length	mm(ft-in)	3800(12' 6")
H	Height	mm(ft-in)	2800(9' 2")
Wd	Width	mm(ft-in)	2490(8' 2")
Wt	Weight	kg(lb)	9280(20460)

※ With 500mm(20") triple grouser shoes and 1450kg(3200lb) counterweight.

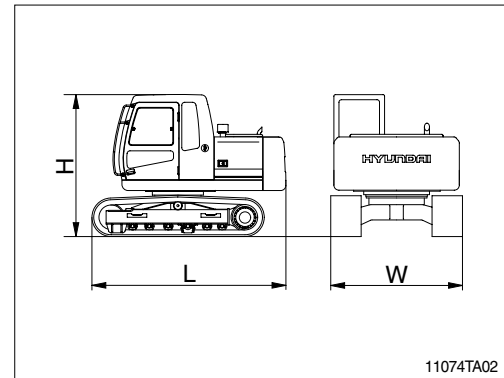

(2) Boom assembly

Mark	Description	Unit	Specification
L	Length	mm(ft-in)	1340(4' 5")
H	Height	mm(ft-in)	4450(14' 7")
W	Width	mm(ft-in)	520(1' 8")
Wt	Weight	kg(lb)	950(2090)

※ 4.3m(14' 1") boom with arm cylinder(Included piping and pins).

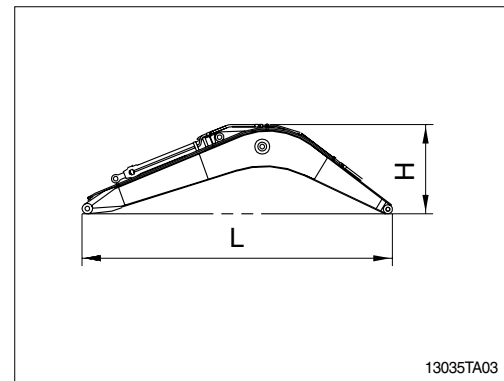

(3) Arm assembly

Mark	Description	Unit	Specification
L	Length	mm(ft-in)	2970(9' 9")
H	Height	mm(ft-in)	680(2' 3")
W	Width	mm(ft-in)	380(1' 3")
Wt	Weight	kg(lb)	530(1170)

※ 2.26m(7' 5") arm with bucket cylinder(Included linkage and pins).

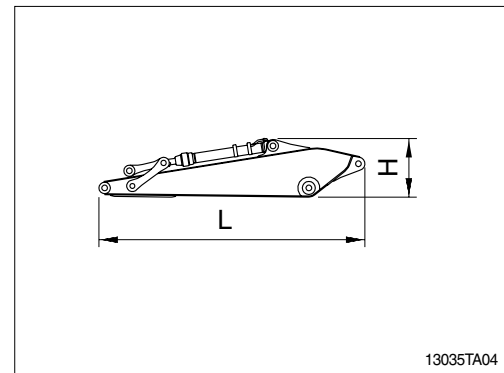

(4) Bucket assembly

Mark	Description	Unit	Specification
L	Length	mm(ft-in)	1350(4' 5")
H	Height	mm(ft-in)	920(3' 0")
W	Width	mm(ft-in)	940(3' 1")
Wt	Weight	kg(lb)	440(970)

※ 0.45m³(0.52yd³) SAE heaped bucket(Included tooth and side cutters).

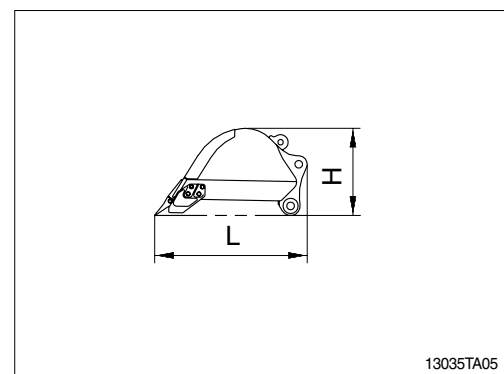

(5) Boom cylinder

Mark	Description	Unit	Specification
L	Length	mm(ft-in)	1650(5' 5")
H	Height	mm(ft-in)	216(0' 9")
W	Width	mm(ft-in)	310(1' 0")
Wt	Weight(2EA)	kg(lb)	230(510)

※ Included piping.

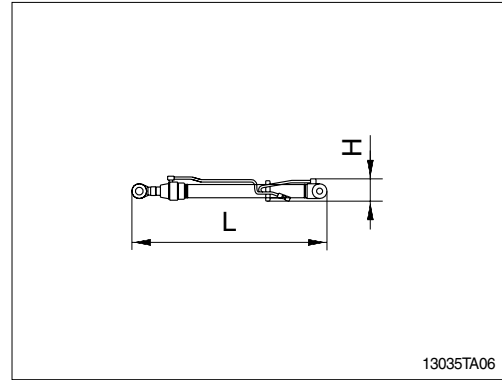

(6) Cab assembly

Mark	Description	Unit	Specification
L	Length	mm(ft-in)	1962(6' 5")
H	Height	mm(ft-in)	1676(5' 6")
W	Width	mm(ft-in)	1288(4' 3")
Wt	Weight	kg(lb)	310(680)

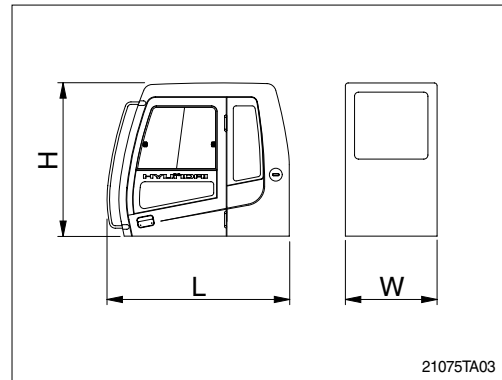

(7) Counterweight

Mark	Description	Unit	Specification
L	Length	mm(ft-in)	2460(8' 1")
H	Height	mm(ft-in)	1050(3' 5")
W	Width	mm(ft-in)	445(1' 6")
Wt	Weight	kg(lb)	1450(3200)

