

3. CONTROL DEVICES

1. LOCATIONS

1) MECHANICAL TYPE

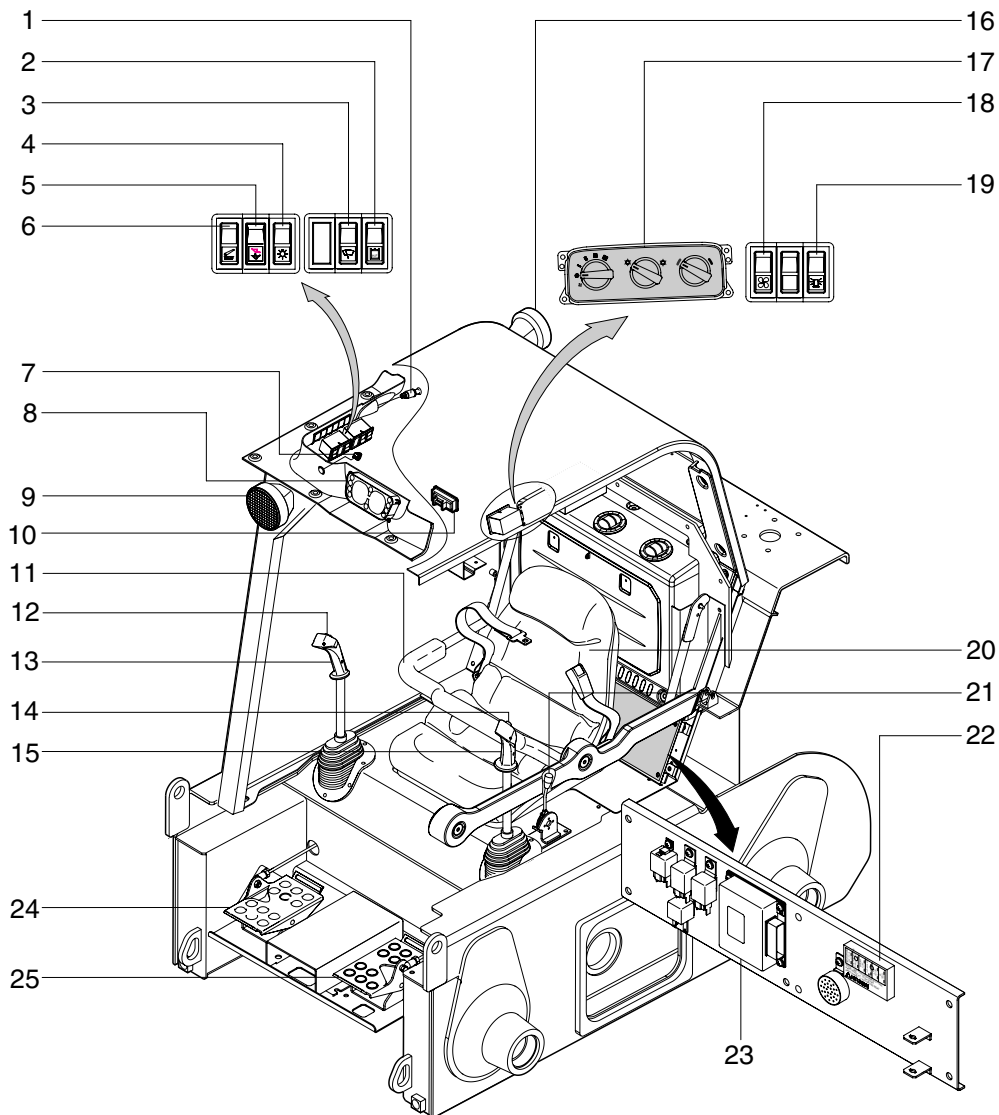

6507A3CD07

- | | | | |
|----|-----------------------------|----|--|
| 1 | Cigar lighter | 14 | Buzzer stop switch |
| 2 | High flow switch(Optional) | 15 | LH control lever |
| 3 | Wiper switch(Optional) | 16 | Rear work light(Optional) |
| 4 | Main light switch | 17 | Aircon & heater controller(Cab type, option) |
| 5 | Self level switch(Optional) | 18 | Heater switch(Cab type, option) |
| 6 | Reset switch | 19 | Beacon switch(Optional) |
| 7 | Start key switch | 20 | Operator's seat |
| 8 | Warning indicator panel | 21 | Engine throttle lever |
| 9 | Front work light(LH, RH) | 22 | Fuse box |
| 10 | Room lamp | 23 | Control unit |
| 11 | Seat bar | 24 | Bucket control pedal |
| 12 | Horn switch | 25 | Boom control pedal |
| 13 | RH control lever | | |

2) JOYSTICK TYPE (Pilot, option)

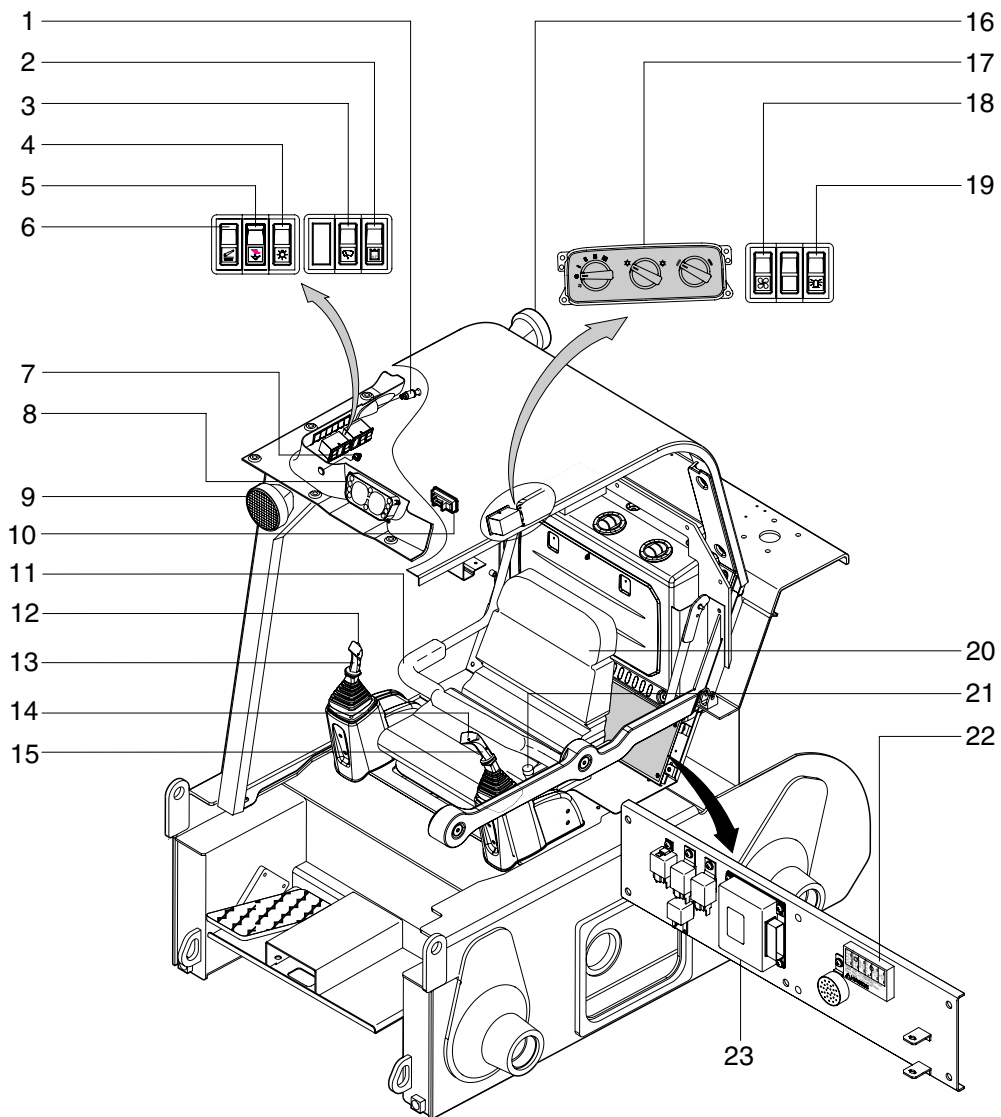

6507A3CD01A

- | | |
|-------------------------------|---|
| 1 Cigar lighter | 13 RH control lever |
| 2 High flow switch(Optional) | 14 Buzzer stop switch |
| 3 Wiper switch(Optional) | 15 LH control lever |
| 4 Main light switch | 16 Rear work light(Optional) |
| 5 Self level switch(Optional) | 17 Aircon & heater controller(Cab type, option) |
| 6 Reset switch | 18 Heater switch(Cab type, option) |
| 7 Start key switch | 19 Beacon switch(Optional) |
| 8 Warning indicator panel | 20 Operator's seat |
| 9 Front work light(LH, RH) | 21 Engine throttle lever |
| 10 Room lamp | 22 Fuse box |
| 11 Seat bar | 23 Control unit |
| 12 Horn switch | |

2. WARNING INDICATOR PANEL

The indicator panel consists of gauges and monitors as shown below, to warn the operator in case of abnormal machine operation or conditions for the appropriate operation and inspection.

- Gauges : Indicate operating status of the machine.
- Warning lamp : Indicate abnormality of the machine.
- Pilot lamp : Indicate operating status of the machine.

※ The monitor installed on this machine does not entirely guarantee the condition of the machine. Daily inspection should be performed according to chapter 6, MAINTENANCE.

※ When the monitor provides a warning immediately check the problem, and perform the required action.

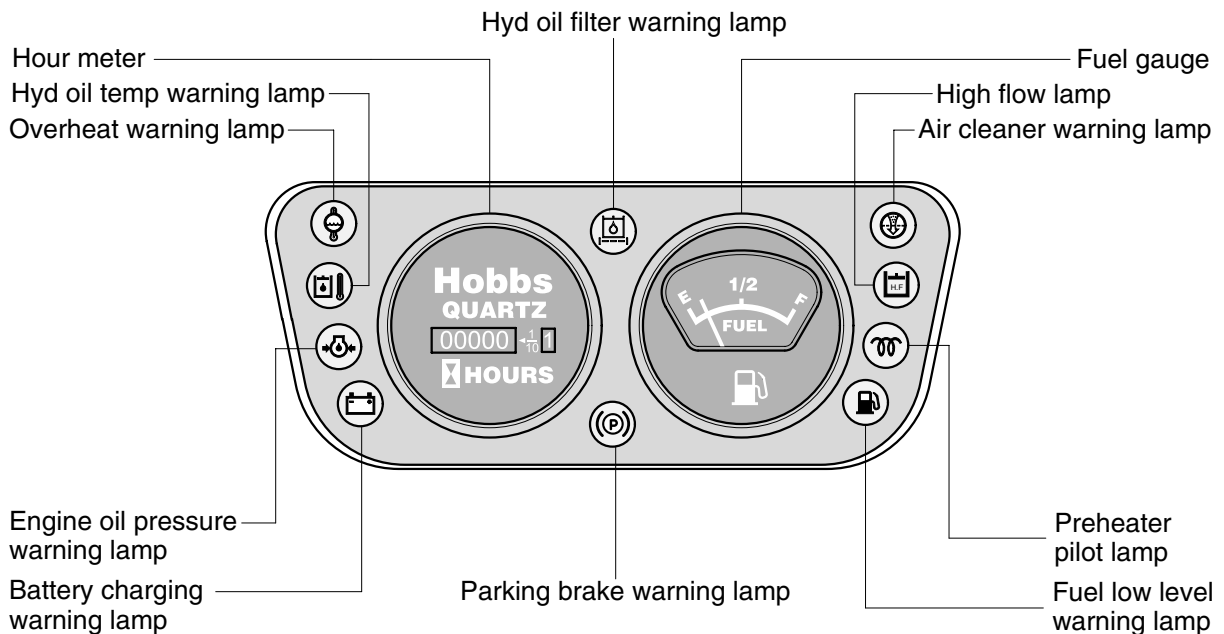

6507A3CD02

1) FUEL GAUGE

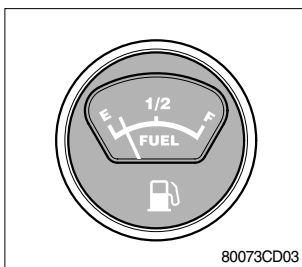

- (1) Indicates the quantity of fuel in the fuel tank.
- (2) It operates when the start switch is ON. **F** indicates full and **E** indicates empty.
- (3) To avoid getting air into the fuel system, refuel before the indicator reaches **E**.

2) HOUR METER

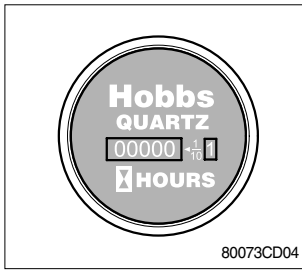

- (1) Records engine operating hours and has a total read out of 9999.9 hours.
- (2) It only operates when the engine is running.

3) HYDRAULIC OIL FILTER WARNING LAMP

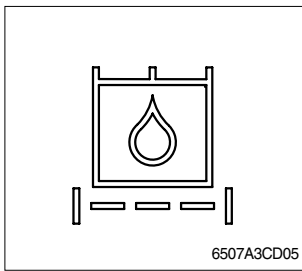

- (1) This lamp is turned ON when the filter of hydraulic oil is clogged.
- (2) Check the filter and replace it.

4) OVERHEAT WARNING LAMP

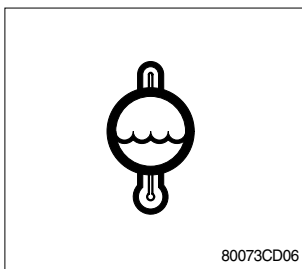

- (1) This lamp is turned ON when the temperature of cooling water is over the 104°C(219°F).
- (2) Check the cooling system when the lamp is ON.

5) HYD OIL TEMPERATURE WARNING LAMP

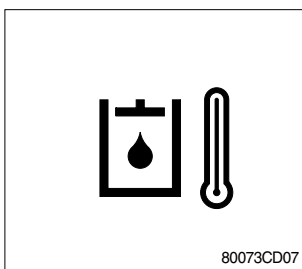

- (1) This warning lamp operates and the buzzer sounds when the temperature of hydraulic oil is over 105°C(221°F).
- (2) Check the hydraulic oil level when the lamp is turned ON.
- (3) Check for debris between oil cooler and radiator.

6) ENGINE OIL PRESSURE WARNING LAMP

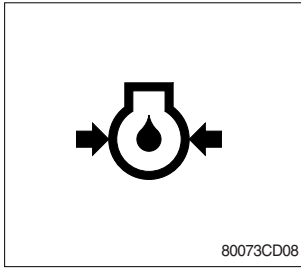

- (1) Light to indicate low engine oil pressure and the buzzer sounds.
 - (2) The lamp comes ON when the start switch is turned ON and should go off when the engine starts.
- ※ **If the lamp comes ON during engine operation, this indicates a malfunction in the lubrications system or an oil shortage, stop operation immediately and have the machine inspected or repaired.**

7) BATTERY CHARGING WARNING LAMP

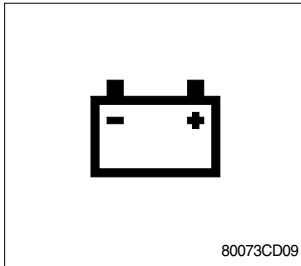

- (1) This lamp is ON when key ON, it is turned OFF after starting the engine.
- (2) Check the battery charging circuit when this lamp comes ON, during engine operation.

8) PARKING BRAKE WARNING LAMP

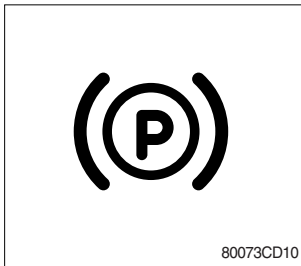

- (1) When the parking brake is actuated, the lamp lights ON.
- ※ **Check the lamp is OFF before driving.**
- (2) When you lower the seat bar and operate the reset switch, this warning lamp is turned OFF.(Ready for operation)

9) AIR CLEANER WARNING LAMP

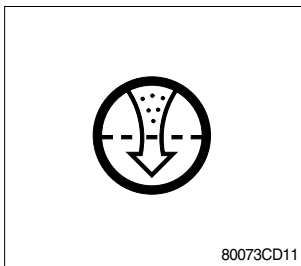

- (1) This lamp operates by the vacuum caused inside when the filter of air cleaner is clogged and the buzzer sounds.
- (2) Check the filter and clean or replace it when the lamp is ON.

10) HIGH FLOW LAMP (Option)

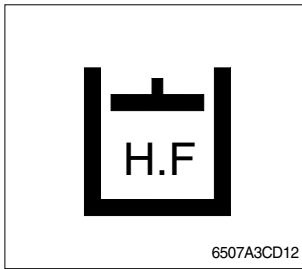

(1) This lamp lights ON when high flow switch is pressed.

11) PREHEATER PILOT LAMP

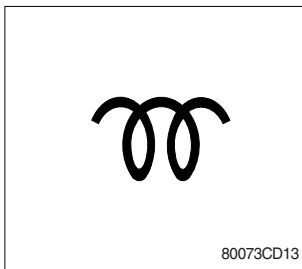

(1) This lamp lights ON when start switch is turned clockwise to the ON position. Light will turn off after approximately 5~20 seconds, depending on engine coolant temperature, indicating that preheating is completed.

(2) When the lamp goes out the operator should start cranking the engine.

※ Refer to page 4-4.

12) FUEL LOW LEVEL WARNING LAMP

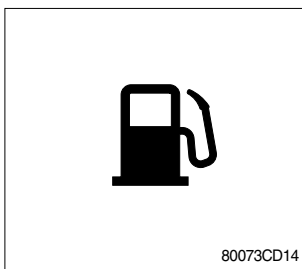

(1) Fill the fuel immediately when the lamp is turned ON.

3. SWITCHES

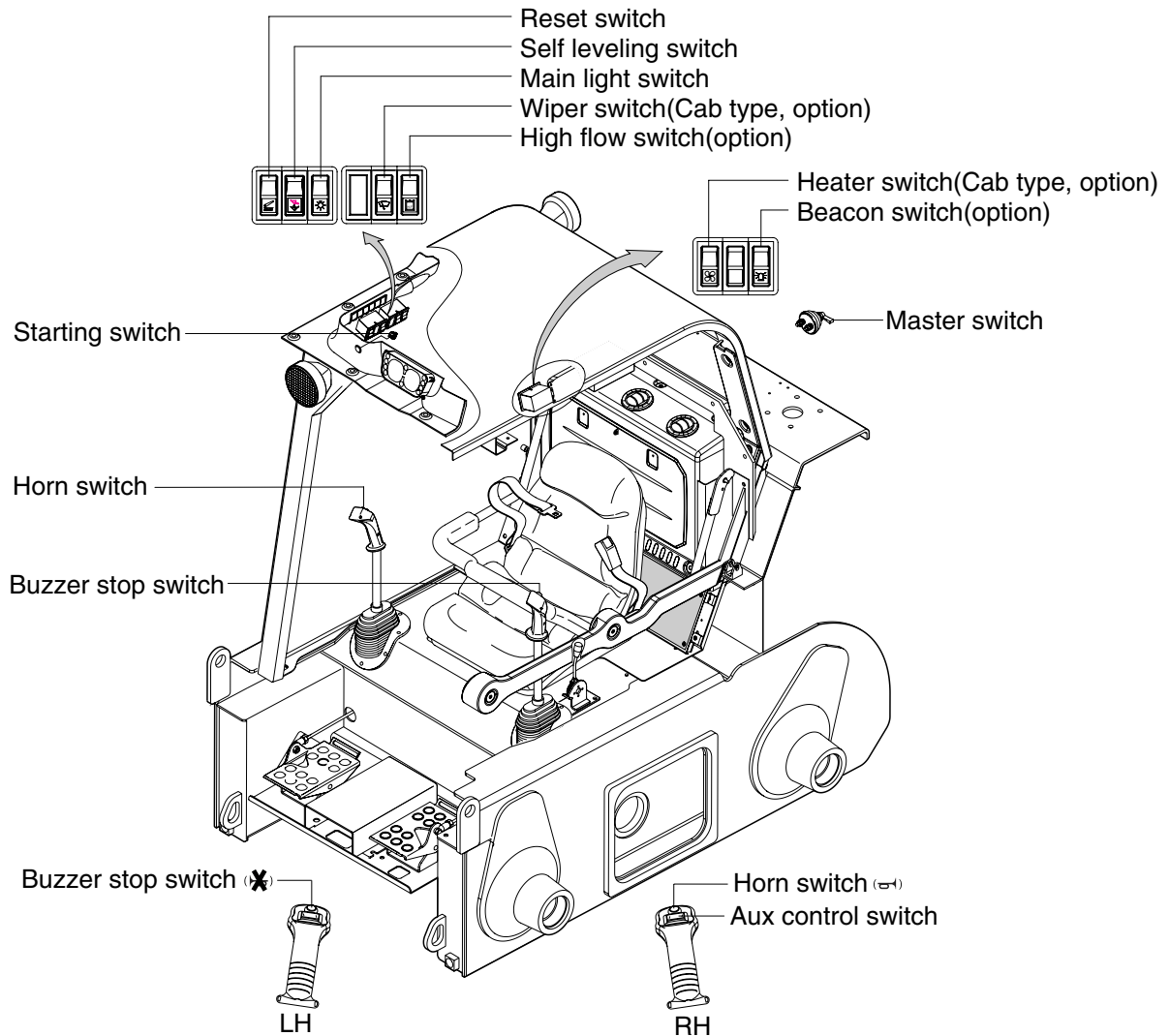

6507A3CD08A

1) STARTING SWITCH

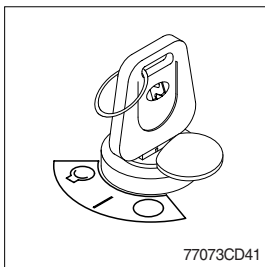

(1) There are three positions, OFF, ON and START.

- ○ (OFF) : None of electrical circuits activate.
- | (ON) : All the systems of machine operate.
- Ⓚ (START) : Use when starting the engine.

Release key immediately after starting.

※ **Key must be in the ON position with engine running maintain electrical and hydraulic function and prevent serious machine damage.**

※ **Turning the key switch to START position while the engine is running, anti-restart function prevents the engine from restarting.**

2) BUZZER STOP SWITCH

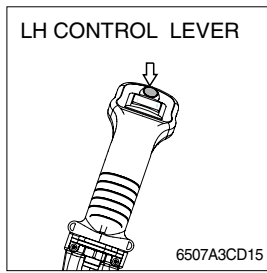

- (1) The buzzer sounds when the machine has a problem.
In this case, if the switch is pressed, the buzzer will be stopped. Be sure to check machine for problems.
- (2) Wait until the lamp is turned OFF, if the warning lamp lights ON after the buzzer stopped.
If not, stop engine and check the system.

3) WIPER SWITCH(Cab type, option)

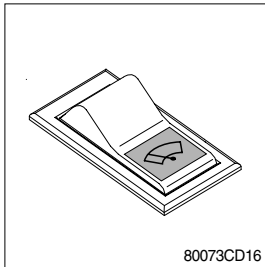

- (1) The switch is used to operate the wiper and washer by two step.
 - First step : The front wiper operates.
 - Second step : The washer liquid is sprayed and the front wiper is operated only while pressing. If release the switch, return to the first step position.
- (2) The below indicator lamp is turned ON when operating this switch.

4) MAIN LIGHT SWITCH

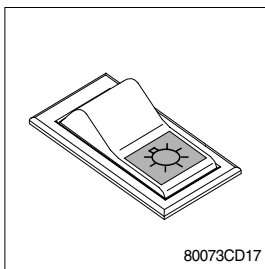

- (1) The switch is used to operate the front and rear work light.
 - First step : Front work lights, cigar light lamp and fuel gauge lamp comes ON.
 - Second step : Rear work light(Optional) comes ON.
- (2) The below indicator lamp is turned ON when operating this switch.

5) RESET SWITCH

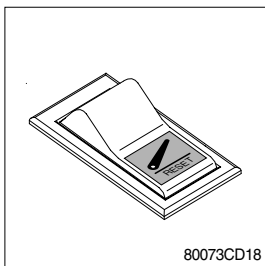

- (1) With seat belt secured, seat bar down and engine running, the operator must momentarily press the reset button before the loader boom raise/lower hydraulic system can be functional.
- (2) The loader boom raise/lower hydraulic system will remain active until the seat bar is raised or the start switch is turned OFF.

6) HEATER SWITCH(Cab type, option)

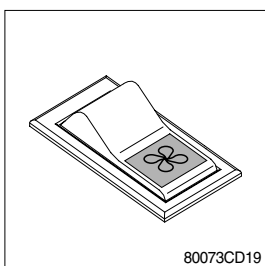

- (1) This switch is used to operate the heater.
- (2) The below indicator lamp is turned ON when operating this switch.

7) SELF LEVEL SWITCH(Optional)

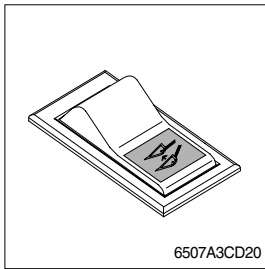

- (1) This switch is used to operate the self leveling.
- (2) The below indicator lamp is turned ON when operating this switch.

8) BEACON SWITCH(Optional)

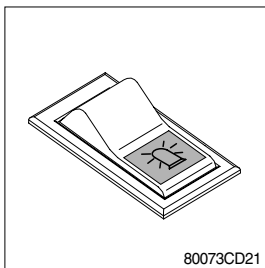

- (1) This switch turns ON the rotary light on the cab roof.
- (2) The below indicator lamp is turned ON when operating this switch.

9) HIGH FLOW SWITCH(Optional)

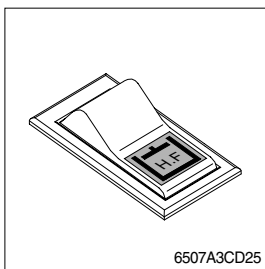

- (1) This switch is used to operate the high flow hydraulic system.
- (2) When turned ON, the discharged oil from the high flow pump flows into the high flow hydraulic system.

10) HORN SWITCH

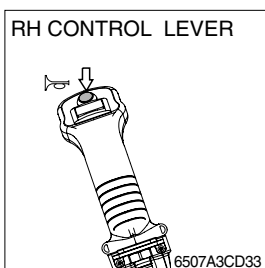

- (1) If you press the bottom on the top of the RH control lever, the horn will sound.

11) AUX CONTROL SWITCH

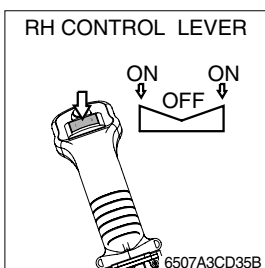

- (1) This switch is used to operate the optional auxiliary attachment.
 - (2) The auxiliary attachment is operated only while pressing the switch to the ON position. When released the switch returns to OFF position automatically.
- ※ **Confirm the switch position and operation of the aux attachment.**

12) MASTER SWITCH

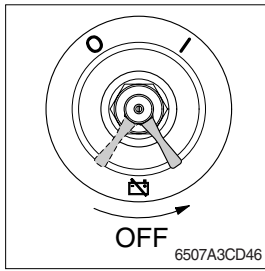

- (1) This switch is used to shut off the entire electrical system.
 - (2) I : The battery remains connected to the electrical system.
O : The battery is disconnected to the electrical system.
- ※ **Never turn the master switch to O(OFF) with the engine running.**
Engine and electrical system damage could result.

4. CONTROL DEVICES

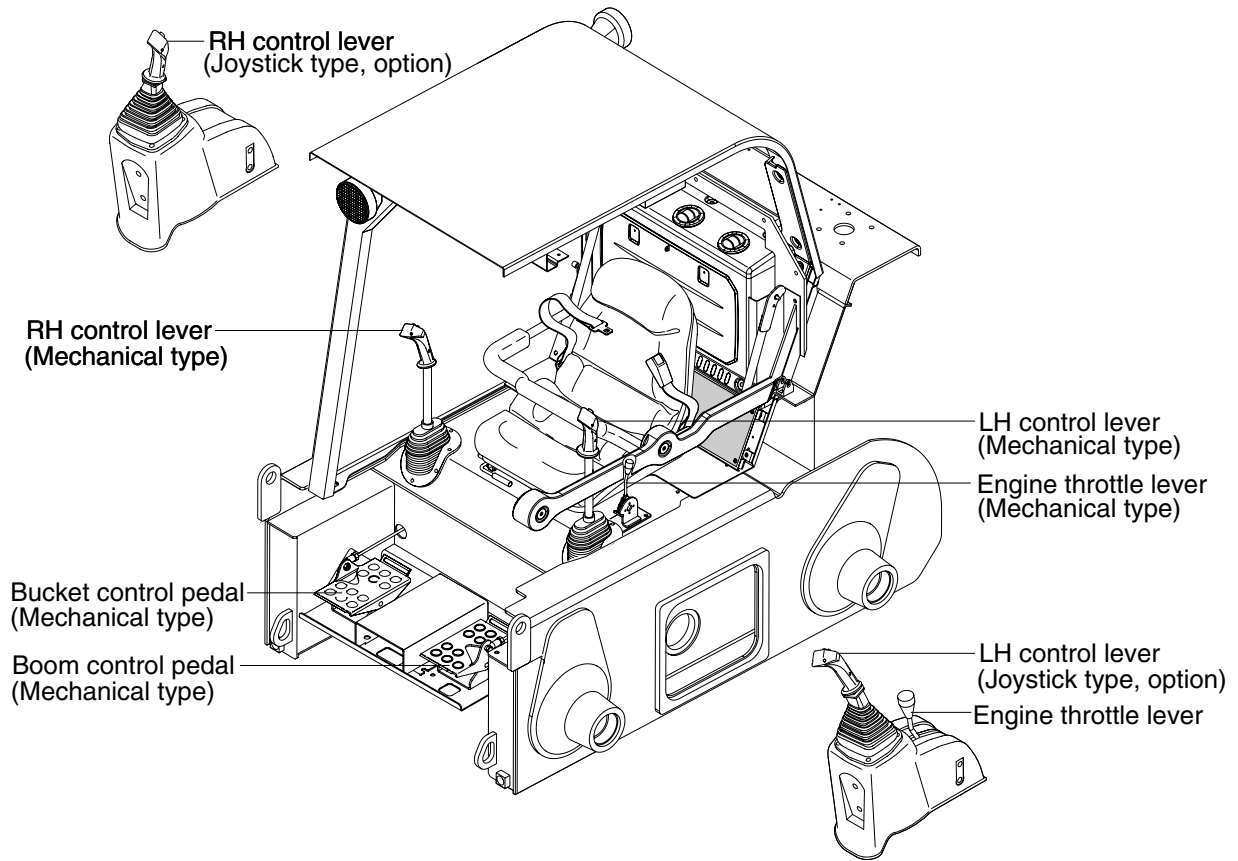

6507A3CD10A

1) ENGINE THROTTLE LEVER

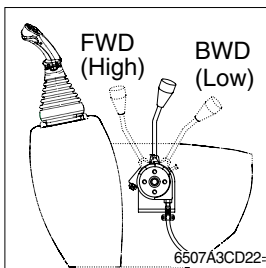

- (1) The engine throttle lever is located the left side of the operator's seat.
- (2) Engine speed is controlled by moving throttle lever forward to increase the engine speed and backward to decrease the engine speed.

▲ Set the engine throttle lever to high position after engine is stopped when tilting the cab.

2) LH CONTROL LEVER(Mechanical type)

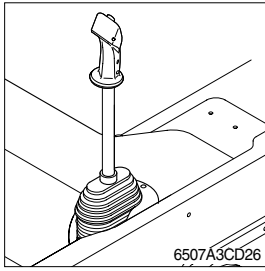

- (1) This control lever is used to control the traveling forward or backward of the left side wheels.
- (2) The speed is adjusted by the degree of lever operation.
※ Refer to operation of working device at page 4-8 for detail.

3) RH CONTROL LEVER(Mechanical type)

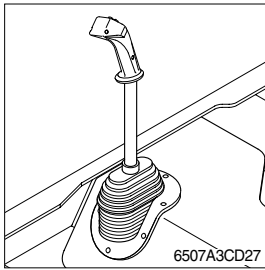

- (1) This control lever is used to control the traveling forward or backward of the right side wheels.
- (2) The speed is adjusted by the degree of lever operation.
※ Refer to operation of working device at page 4-8 for detail.
- (3) Also, this control lever is used to control the optional auxiliary attachment by pressing aux control switch.
※ Refer to page 3-9, 11) Aux control switch.

4) LH CONTROL LEVER(Joystick type, opt)

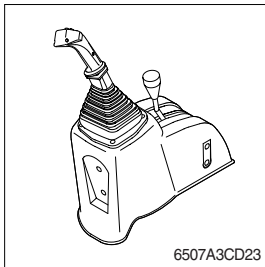

- (1) This control lever is used to control the steering and the traveling.
※ Refer to operation of working device at page 4-9 for detail.

5) RH CONTROL LEVER(Joystick type, opt)

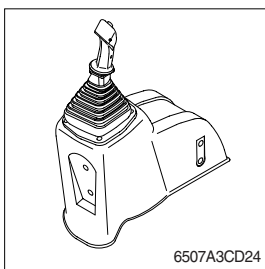

- (1) This control lever is used to control the boom and the bucket.
※ Refer to operation of working device at page 4-9 for detail.
- (2) Also, this control lever is used to control the optional auxiliary attachment by pressing aux control switch.
※ Refer to page 3-9, 11) Aux control switch.

6) BOOM CONTROL PEDAL(Mechanical type)

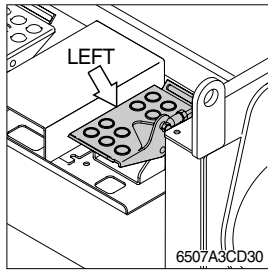

This foot pedal is used to control the boom up and down.

(1) Boom up

Press the rear of the left foot pedal to raise the boom.

(2) Boom down

Press the front of the left foot pedal to lower the boom.

(3) Float

Pressing the front of the left foot pedal all the way down until you feel it lock the pedal in the detent position.

This allows the boom to float an implement with the contour of the ground. Depress the rear of the left foot pedal to release from the float position.

The float position may be used as follows.

- With a bucket when back-dragging.
- With an optional auger implement it allows the boom to lower it the same rate that the auger is digging.
- With an optional broom implement, it allows the boom to float the broom with the contour of the ground.

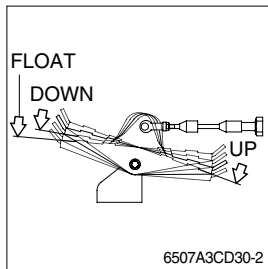

7) BUCKET CONTROL PEDAL(Mechanical type)

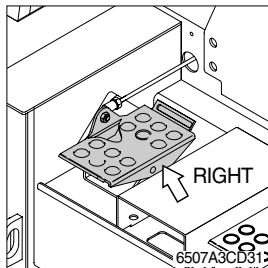

This foot pedal is used to control the bucket dump and roll back.

(1) Bucket dump

Press the front of the right foot pedal to tilt the attachment holder forward.

(2) Bucket roll back

Press the rear of the right foot pedal to tilt the attachment holder backward.

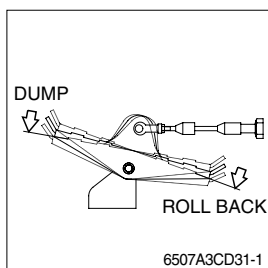

5. AIR CONDITIONER AND HEATER(CAB TYPE)

Air conditioner and heater are equipped for pleasant operation against outside temperature.

- Location of air outlet

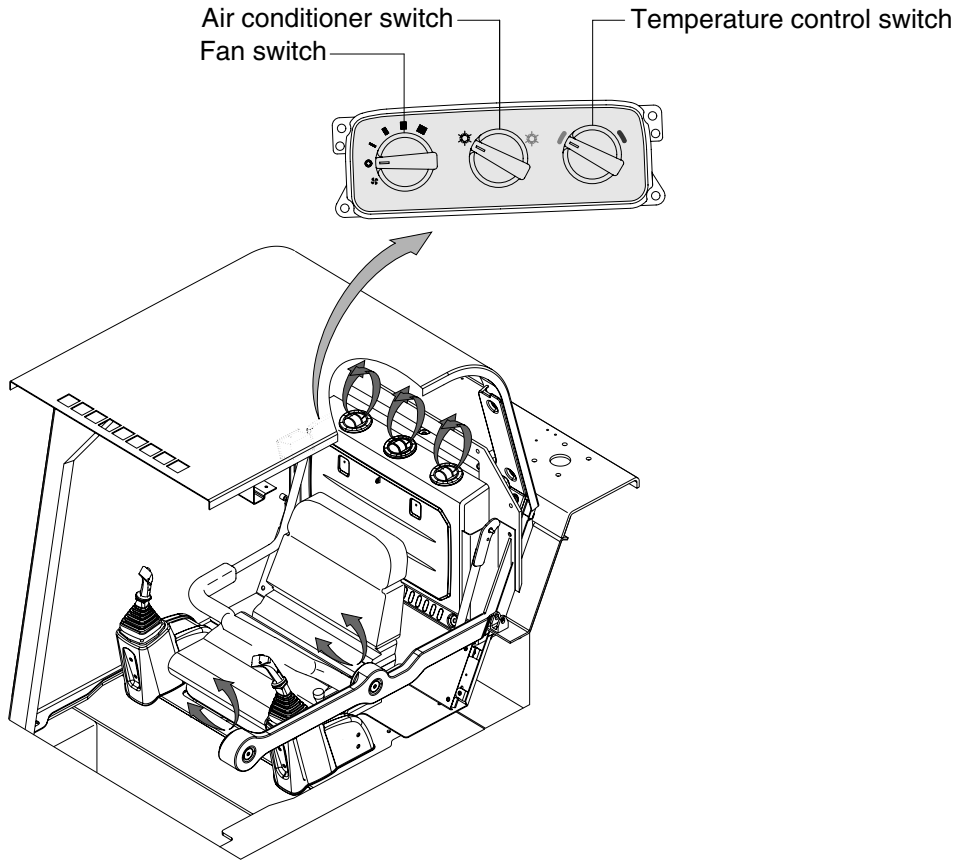



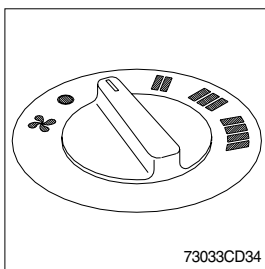

6507A3CD29

1) FAN SWITCH





It is possible to control the fan to four steps.

-  : Low
-  : Medium-Low
-  : Medium-High
-  : High

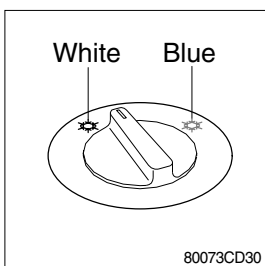
2) AIR CONDITIONER SWITCH



This switch use to operates the air conditioner.

-  (White) : Air conditioner ON
-  (Blue) : Air conditioner OFF

3) TEMPERATURE CONTROL SWITCH

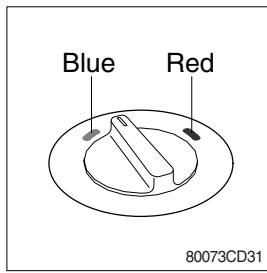

(1) Cooling(Air conditioner switch : ON)

- ① Turned ON the air conditioner switch on the controller.
- ② Turn the control switch into blue range to decrease output air temperature.

(2) Heating(Air conditioner switch : OFF)

- ① Turned OFF the air conditioner switch on the controller.
- ② Turn the control switch into red range to increase temperature.

4) OUTLET CONTROL LOUVER

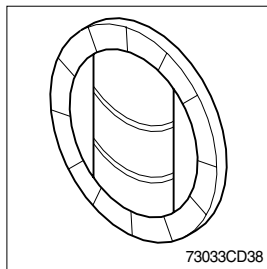

(1) The direction of air can be controlled.

(2) It can be closed or opened.

6. OTHERS

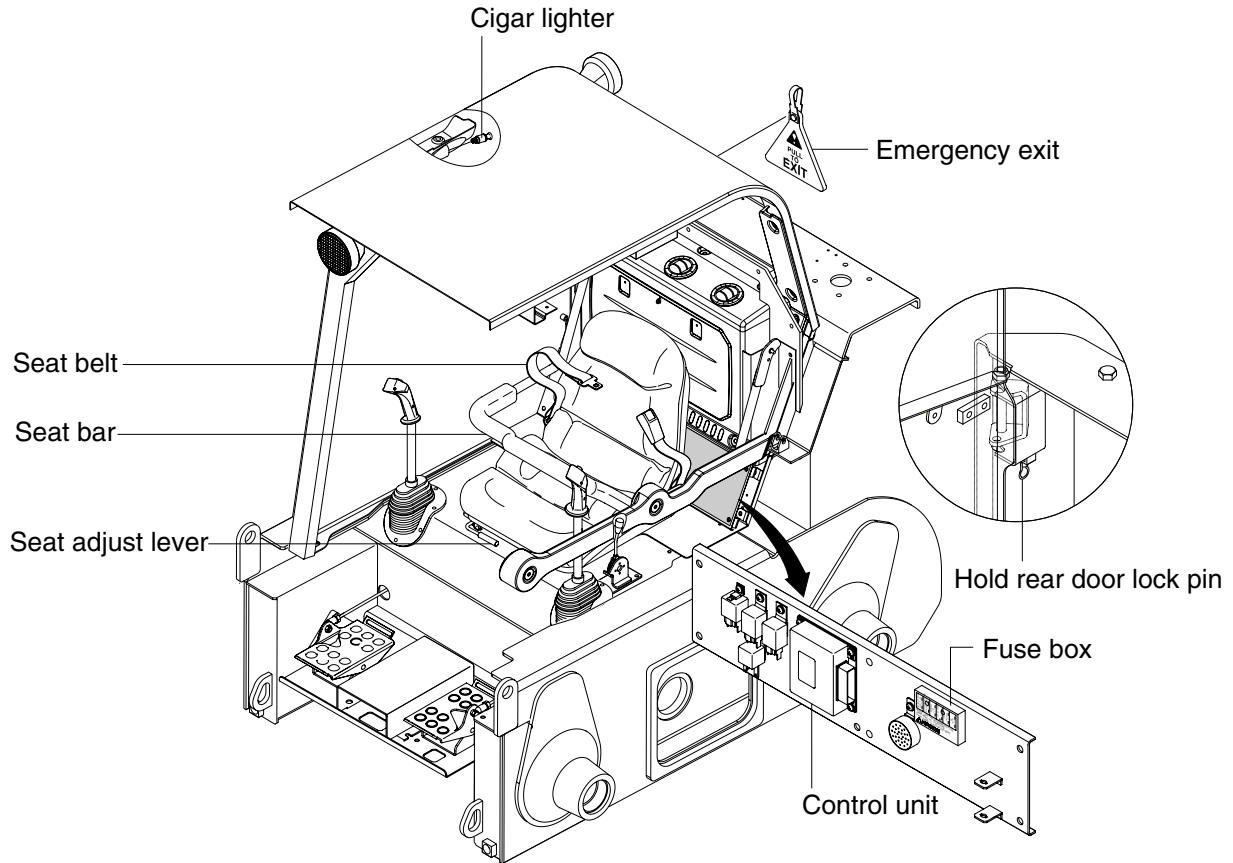

6507A3CD09

1) CIGAR LIGHTER

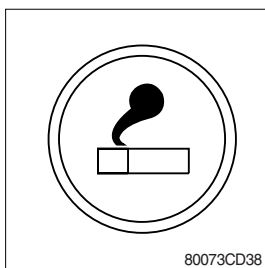

- (1) This can be used when the engine starting switch is ON.
- (2) The lighter can be used when it springs out in a short while after being pressed down.
- (3) The indicator lamp is turned ON when the main light switch is pressed by first step.

※ **Service socket**

**Use cigar lighter socket when you need emergency power.
Do not use the lighter exceeding 12V, 120W**

2) SEAT BAR

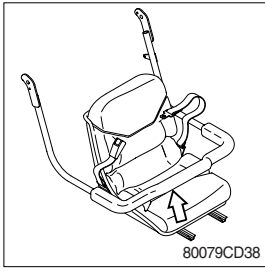

- (1) With your seat belt fastened, the seat bar raised and the engine running ; Loader does not move when you move either control lever forward or backward.
- (2) Parking brake must engage(ON) when you raise the bar and disengage(OFF) when you lower the bar and operate the reset switch.

※ **Especially when leaving the driver's seat, be absolutely careful for the following points:**

- Always return the control lever to its neutral position if it remains in the floating stage.
- Make certain there are no articles on the operator's seat.
- Disconnect the seat belt.
- Make sure the start switch is turned OFF.
- Raise the seat bar.
- Carefully exit the loader using the hand holds.

3) SEAT BELT

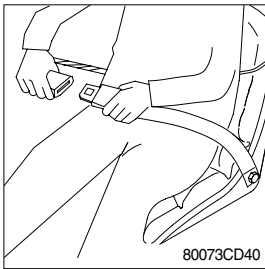

- (1) When buckling the belt, make sure that it is not twisted and insert the plate on the right side into the buckle on the left until it clicks to the position.
- (2) When the belt length is short, lengthen the belt by adjusting it as illustrated.
- (3) Pull the belt to eliminate any slack, as illustrated.

▲ Always buckle the seat belt when operating the machine.

▲ Always make sure the seat belt is disconnected when leaving the operator's seat.

4) OPERATORS SEAT

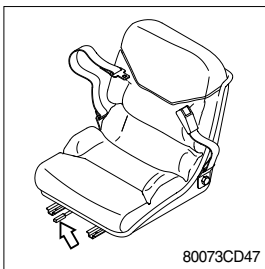

- (1) Forward and backward adjustment is possible using the adjust lever.
- (2) The seat can be moved forward and backward over 150mm(5.9in).
- (3) Adjust to a comfortable operating position.

5) FUSE BOX

 HYUNDAI	안전 솔레노이드 SAFETY SOL. — 15A —
	엔진스톱 솔 옵션 CIGAR, OPTION — 20A —
	라이트 LIGHT — 25A —
	실내등, 계기판 ROOM & INDICATOR — 20A —
	옵션 OPTION — 20A —
	혼 HORN — 15A —

NOTE : USE THE DESIGNATED FUSE.
 PART NO(품번) : 21S4-01040
 PART NAME : 퓨즈박스 (FUSE BOX)

80073CD41

- (1) The fuses protect the electrical parts and wiring from burning out.
- (2) The fuse box cover indicates the capacity of each fuse and circuit it protects.

※ Replace a fuse with another of the same capacity.

▲ Before replacing a fuse, be sure to turn OFF the starting switch.

6) CONTROL UNIT

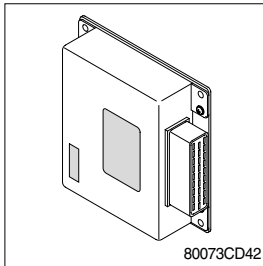

80073CD42

- (1) It consists of electronic parts and controls all lamps and buzzers on indicator panel in accordance with signals transmitted from the switches, the engine and the hydraulic pressure sensors.

7) EMERGENCY EXIT

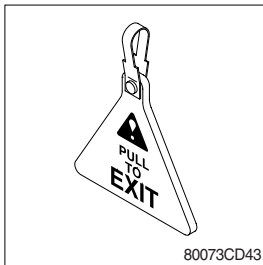

80073CD43

- (1) The front opening on the operator cab and rear window provide exits.
- (2) To exit through the rear window, use the following procedure.
 - ① Pull on the tag at the rear window to remove the rubber cord.
 - ② Push the rear window out of the rear of the operation cab.
 - ③ Exit through the rear of the cab.

8) HOLD REAR DOOR IN OPENING

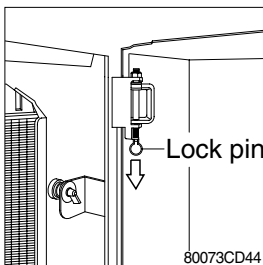

80073CD44

- (1) Open the rear door fully(about 95°), then the rear door is hold automatically by lock pin and pull down the lock pin to close the rear door.