

### 1. INSTRUCTION

#### 1) INTERVAL OF MAINTENANCE

- (1) You may inspect and service the machine by the period as described at page 6-11 based on hour meter at control panel.
- (2) Shorten the interval of inspect and service depending on site condition.(Such as dusty area, quarry, sea shore and etc.)
- (3) Practice the entire related details at the same time when the service interval is doubled.  
For example, in case of 500 hours, carry out all the maintenance 「Each 500 hours, each 250 hours, each 50 hours and daily service」 at the same time.

#### 2) PRECAUTION

- (1) Start maintenance after you have the full knowledge of machine.
- (2) The warning indicator panel installed on this machine does not entirely guarantee the condition of the machine.  
Daily inspection should be performed according to **chapter 6, maintenance**.
- (3) Engine and hydraulic components have been preset in the factory.  
Do not allow unauthorized personnel to reset them.
- (4) Ask to your local dealer or Hyundai for the maintenance advise if unknown.
- (5) Drain the used oil and coolant in a container and handle according to the method of handling for industrial waste to meet with regulations of each province or country.

### 3) PROPER MAINTENANCE

#### (1) Replace and repair of parts

It is required to replace the wearable and consumable parts such as bucket, filter and etc., regularly.

Replace damaged or worn parts at proper time to keep the performance of machine.

- (2) Use genuine parts.
- (3) Use the recommended oil.
- (4) Remove the dust or water around the inlet of oil tank before supplying oil.
- (5) Drain oil when the temperature of oil is warm.
- (6) Do not repair anything while operating the engine.  
Stop the engine when you fill the oil.
- (7) Relieve hydraulic system of the pressure by opening of breather when repairing the hydraulic system.
- (8) For more detail information of maintenance, please contact local Hyundai dealer.

※ **Be sure to start the maintenance after fully understand the chapter 1, safety hints.**

### 4) PRECAUTION WHEN INSTALLING HYDRAULIC HOSES OR PIPES

- (1) Be particularly careful that the joint of hose, pipe and functioning item are not damaged.  
Avoid contamination.
- (2) Assemble after cleaning the hose, pipe and joint of functioning item.
- (3) Use genuine parts.
- (4) Do not assemble the hose in the condition of twisted or sharp radius.
- (5) Keep the specified tighten torque.

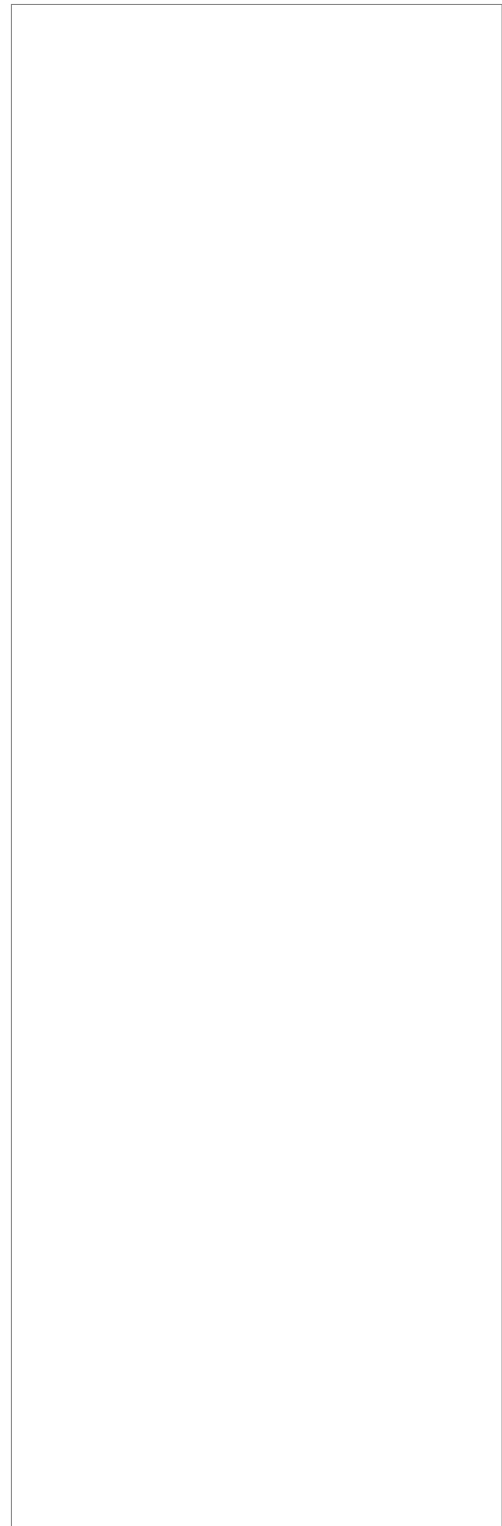

## 2. GENERAL MAINTENANCE

**▲ Do not perform service or maintenance on the loader with the engine running. Contact with moving parts can cause injury or death.**

### SAFETY CHECK LIST

Inspect the following safety equipment daily.

#### 1) SEAT BELT

Check for frayed and cut webbing, damaged buckles, or loose mounting brackets.

#### 2) ROLL OVER PROTECTIVE STRUCTURE(ROPS)

Check for damage or loose mountings. If the ROPS has been damaged, replacement must be made only by and authorized Hyundai dealer.

#### 3) SAFETY TREADS

Keep treads clean. Replace if worn, damaged, or missing.

#### 4) SHIELDS

Keep all protective shields in place.

#### 5) SEAT BAR

Check operation.

#### 6) ATTACHMENT ASSEMBLY

Make sure assembly is pinned securely to the tilt cylinder and boom.

If an attachment is installed, check that lock pins are inserted completely into the attachment.

#### 7) BOOM LOCKS

Check operation.

#### 8) OPERATING LIGHTS

Turn the light switch to the right to **First step** and **Second step** and check operation of work lights.

Replace any that are not functional.

#### 9) ENGINE

Check cleanliness.

Remove all dirt or debris and all flammable material before running the engine.

### 3. TIGHTENING TORQUE

Use following table for unspecified torque.

#### 1) BOLT AND NUT

##### (1) Coarse thread

Bolt size	8T		10T	
	kgf · m	lbf · ft	kgf · m	lbf · ft
M 6 × 1.0	0.85 ~ 1.25	6.15 ~ 9.04	1.14 ~ 1.74	8.2 ~ 12.6
M 8 × 1.25	2.0 ~ 3.0	14.5 ~ 21.7	2.73 ~ 4.12	19.7 ~ 29.8
M10 × 1.5	4.0 ~ 6.0	28.9 ~ 43.4	5.5 ~ 8.3	39.8 ~ 60
M12 × 1.75	7.4 ~ 11.2	53.5 ~ 79.5	9.8 ~ 15.8	71 ~ 114
M14 × 2.0	12.2 ~ 16.6	88.2 ~ 120	16.7 ~ 22.5	121 ~ 167
M16 × 2.0	18.6 ~ 25.2	135 ~ 182	25.2 ~ 34.2	182 ~ 247
M18 × 2.5	25.8 ~ 35.0	187 ~ 253	35.1 ~ 47.5	254 ~ 343
M20 × 2.5	36.2 ~ 49.0	262 ~ 354	49.2 ~ 66.6	356 ~ 482
M22 × 2.5	48.3 ~ 63.3	350 ~ 457	65.8 ~ 98.0	476 ~ 709
M24 × 3.0	62.5 ~ 84.5	452 ~ 611	85.0 ~ 115	615 ~ 832
M30 × 3.5	124 ~ 168	898 ~ 1214	169 ~ 229	1223 ~ 1655
M36 × 4.0	174 ~ 236	1261 ~ 1703	250 ~ 310	1808 ~ 2242

##### (2) Fine thread

Bolt size	8T		10T	
	kgf · m	lbf · ft	kgf · m	lbf · ft
M 8 × 1.0	2.17 ~ 3.37	15.7 ~ 24.3	3.04 ~ 4.44	22.0 ~ 32.0
M10 × 1.25	4.46 ~ 6.66	32.3 ~ 48.2	5.93 ~ 8.93	42.9 ~ 64.6
M12 × 1.25	7.78 ~ 11.58	76.3 ~ 83.7	10.6 ~ 16.0	76.6 ~ 115
M14 × 1.5	13.3 ~ 18.1	96.2 ~ 130	17.9 ~ 24.1	130 ~ 174
M16 × 1.5	19.9 ~ 26.9	144 ~ 194	26.6 ~ 36.0	193 ~ 260
M18 × 1.5	28.6 ~ 43.6	207 ~ 315	38.4 ~ 52.0	278 ~ 376
M20 × 1.5	40.0 ~ 54.0	289 ~ 390	53.4 ~ 72.2	386 ~ 522
M22 × 1.5	52.7 ~ 71.3	381 ~ 515	70.7 ~ 95.7	512 ~ 692
M24 × 2.0	67.9 ~ 91.9	491 ~ 664	90.9 ~ 123	658 ~ 890
M30 × 2.0	137 ~ 185	990 ~ 1338	182 ~ 248	1314 ~ 1795
M36 × 3.0	192 ~ 260	1389 ~ 1879	262 ~ 354	1893 ~ 2561

## 2) PIPE AND HOSE(FLARE TYPE)

Thread size(PF)	Width across flat(mm)	kgf · m	lbf · ft
1/4"	19	4	28.9
3/8"	22	5	36.2
1/2"	27	9.5	68.7
3/4"	36	18	130
1"	41	21	152
1-1/4"	50	35	253

## 3) PIPE AND HOSE(ORFS TYPE)

Thread size(UNF)	Width across flat(mm)	kgf · m	lbf · ft
9/16-18	19	4	28.9
11/16-16	22	5	36.2
13/16-16	27	9.5	68.7
1-3/16-12	36	18	130
1-7/16-12	41	21	152
1-11/16-12	50	35	253

## 4) FITTING

Thread size(PF)	Width across flat(mm)	kgf · m	lbf · ft
1/4"	19	4	28.9
3/8"	22	5	36.2
1/2"	27	9.5	68.7
3/4"	36	18	130
1"	41	21	152
1-1/4"	50	35	253

## 4. SPECIFICATION OF FUEL, COOLANT AND LUBRICANTS

### 1) NEW MACHINE

New machine used and filled with following lubricants.

Description	Specification
Engine oil	SAE 15W-40(API CH-4)
Hydraulic oil	ISO VG 46
Chain case	SAE 15W-40
Grease	Lithium base grease NLGI NO.2
Fuel	ASTM D975-No.2
Coolant	Mixture of 50% ethylene glycol base antifreeze and 50% water

**SAE** : Society of Automotive Engineers

**API** : American Petroleum Institute

**ISO** : International Organization for Standardization

**NLGI** : National Lubricating Grease Institute

**ASTM** : American Society of Testing and Material

## 2) RECOMMENDED OILS

Use only oils listed below or equivalent.

Do not mix different brand oil.

Service point	OKind of fluid	Capacity l (U.S. gal)	Ambient temperature °C( °F)						
			-20 (-4)	-10 (14)	0 (32)	10 (50)	20 (68)	30 (86)	40 (104)
Engine oil pan	Engine oil	13.2(3.5)	SAE 15W-40						
			SAE 30						
			SAE 10W						
			SAE 10W-30						
Chain case	Engine oil	Right : 9.2(2.4) Left : 9.2(2.4)	SAE 10W-30						
Hydraulic tank	Hydraulic oil	Tank; 56(14.8) System; 68(18.0)	ISO VG 32						
			ISO VG 46						
			ISO VG 68						
Fuel tank	Diesel fuel	83(21.9)	ASTM D975 NO.1						
			ASTM D975 NO.2						
Fitting (Grease nipple)	Grease	As required	NLGI NO.1						
			NLGI NO.2						
Radiator	Mixture of antifreeze and water 50 : 50	10.3(2.7)	Ethylene glycol base permanent type						

## 5. MAINTENANCE CHECK LIST

### 1) 10 HOURS OR DAILY SERVICE

Check items	Service	Page
Hydraulic oil level	Check, Add	6-20
Seat bar(Function)	Check	-
Radiator coolant level	Check, Add	6-13
Engine oil level	Check, Add	6-12
Grease pin	Check, Add	6-25
Fan belt(Tension, damage)	Check	6-16
Water separator	Check	6-19
Wheel nut(Torque)	Check, Tight	6-23
Tire(Air)	Check, Add	6-22

### 2) INITIAL 50 HOURS SERVICE

Check items	Service	Page
Battery(Voltage)	Check	6-26
Engine oil	Change	6-12
Engine oil filter	Replace	6-13
Hydraulic oil	Change	6-20
Hydraulic oil return filter	Replace	6-21
Chain case oil	Check, Add	6-24

### 3) 50 HOURS SERVICE

Check items	Service	Page
Hydraulic tank air breather	Check, Clean	6-21
Water separator	Check, Clean	6-19

### 4) 250 HOURS SERVICE

Check items	Service	Page
Battery(Voltage)	Check	6-26
Hydraulic oil return filter	Replace	6-20
Fuel filter	Check, Clean	6-18

### 5) 500 HOURS SERVICE

Check items	Service	Page
Air cleaner(Element)	Check, Clean	6-17
Engine oil	Change	6-12
Engine oil filter	Replace	6-13
Fuel filter	Replace	6-18

### 6) 1000 HOURS SERVICE

Check items	Service	Page
Hydraulic oil	Change	6-21
Radiator coolant	Change	6-14, 15
Hydraulic oil suction strainer	Check, Clean	6-21
Chain case oil	Change	6-24

## 6. MAINTENANCE CHART

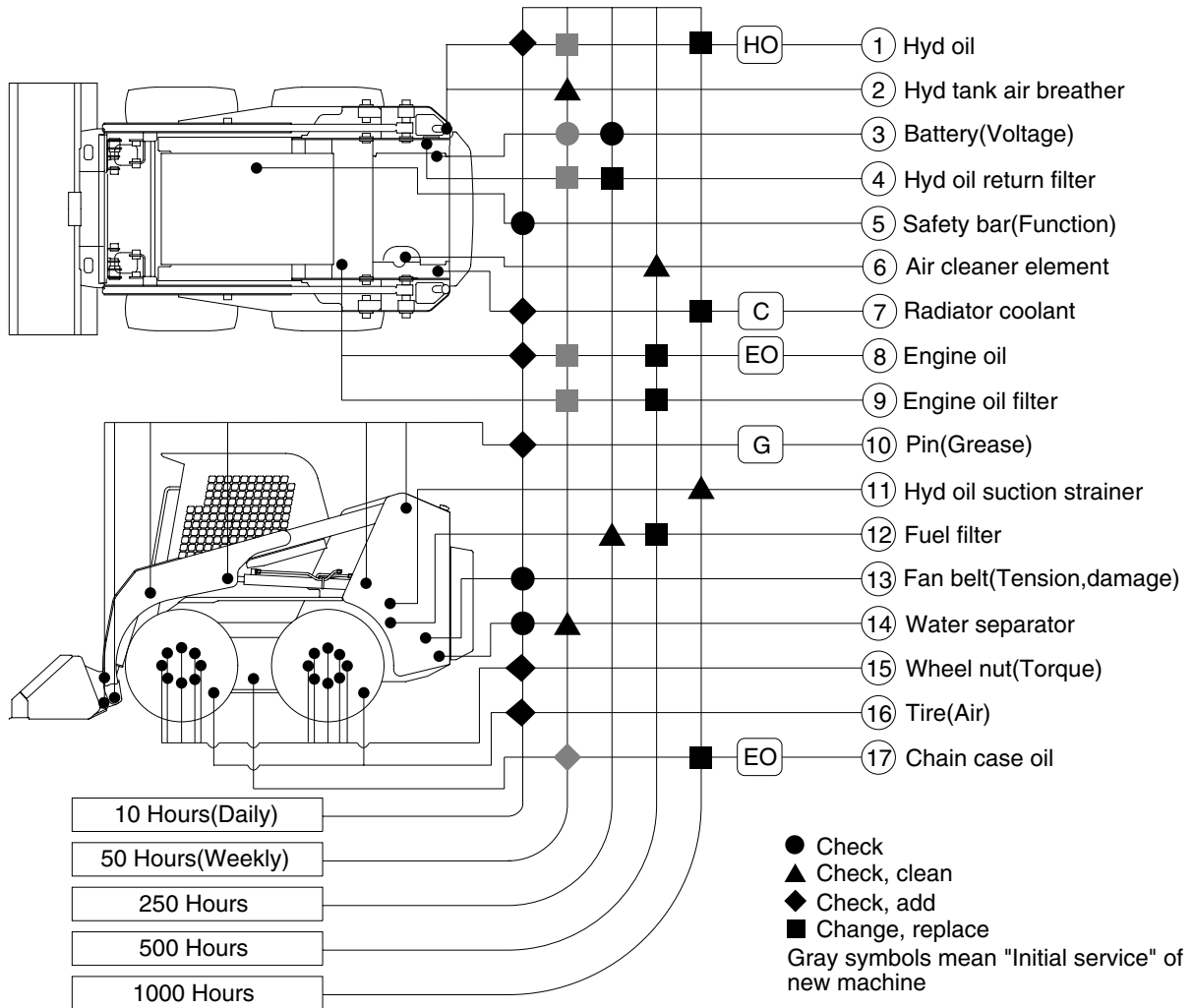

80076M119

Service interval	No.	Description	Service action	Oil symbol	Capacity l (U.S.gal)	Service points No.
10 Hours or daily	1	Hydraulic oil level	Check, Add	HO	56(14.8)	1
	5	Seat bar(Function)	Check	-	-	1
	7	Radiator coolant level	Check, Add	C	10.3(2.7)	1
	8	Engine oil level	Check, Add	EO	13.2(3.5)	1
	10	Grease pin	Check, Add	G	-	12
	13	Fan belt(Tension, damage)	Check	-	-	1
	14	Water separator	Check	-	-	1
	15	Wheel nut(Torque)	Check, Tight	-	-	32
	16	Tire(Air)	Check, Add	-	-	4
Initial 50 hours	1	Hydraulic oil	Change	HO	56(14.8)	1
	3	Battery(Voltage)	Check	-	-	1
	4	Hydraulic oil return filter	Replace	-	-	1
	8	Engine oil	Change	EO	13.2(3.5)	1
	9	Engine oil filter	Replace	-	-	1
	17	Chain case oil	Check, Add	EO	9.2(2.4)	2
50 Hours	2	Hydraulic tank air breather	Clean	-	-	1
	14	Water separator	Check, Clean	-	-	1
250 Hours	3	Battery(Voltage)	Check	-	-	1
	4	Hydraulic oil return filter	Replace	-	-	1
	12	Fuel filter	Check, Clean	-	-	1
500 Hours	6	Air cleaner(Element)	Check, Clean	-	-	1
	8	Engine oil	Change	EO	13.2(3.5)	1
	9	Engine oil filter	Replace	-	-	1
	12	Fuel filter	Replace	-	-	1
1000 Hours	1	Hydraulic oil	Change	HO	56(14.8)	1
	7	Radiator coolant	Change	C	10.3(2.7)	1
	11	Hydraulic oil suction strainer	Check, Clean	-	-	1
	17	Chain case oil	Change	EO	9.2(2.4)	2

※ 1. Oil symbol

Please refer the recommended lubricants for specification.

EO : Engine oil SAE 15W-40(API CH-4)    HO : Hydraulic oil ISO VG 46    C : Coolant  
 G : Grease    D : Diesel fuel oil

2. Service intervals are based on the hour meter reading.
3. Number of each item shows the lubricating position in the chart.
4. Stop engine when filling oil and use no naked flame.
5. Do not mix with different brand lubricant.
  - When refilling oil, use the same brand lubricant.
  - When replacing oil, use the same brand lubricant or the equivalent.
6. Do not open the cap or drain plug to avoid injury by unexpected spouting of high temperature fluid or gas.
7. Open the cap slowly to relieve pressure.
8. Always keep the surfaces of control & instrument panel clean.
 

In case of damage or malfunction detected in panel, replace it by a new one.
9. Specifications of oils can be changed in accordance with the ambient temperature.

## 7. SERVICE INSTRUCTION

### 1) CHECK ENGINE OIL LEVEL

Check the oil level with the machine on a flat ground before starting engine.

- (1) To check the oil level, pull out the dipstick, wipe it clean, reinsert it, and pull it out again.
  - (2) Check to see that the oil level lies between the two notches.
  - (3) If the level is too LOW, add new oil to the specified level.
- ※ If the oil is contaminated or diluted, change the oil regardless of the regular change interval.
  - ※ Check oil level after engine has been stopped for 15 minutes.
  - ▲ Do not operate unless the oil level is in the normal range.

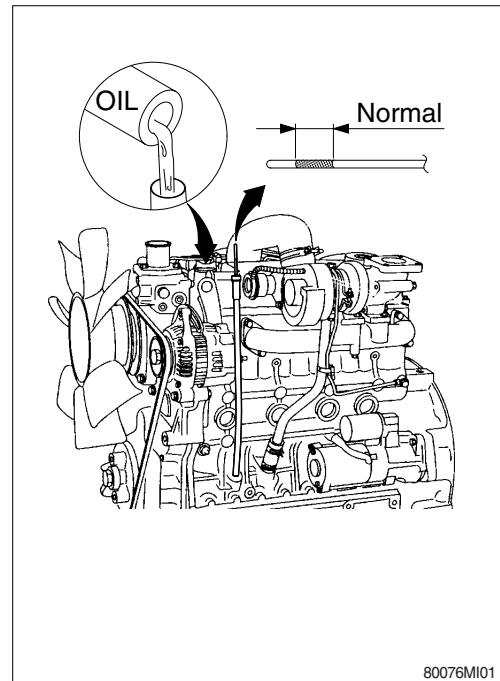

### 2) CHANGING ENGINE OIL

- ※ Be sure to stop engine before changing engine oil.
- (1) Start and warm up the engine for approximately 5 minutes.
  - (2) Place an oil pan underneath the engine.
  - (3) To drain the used oil, remove the drain plug at the bottom of the engine and drain the oil completely.
  - (4) Screw the drain plug.
  - (5) Fill new oil up to upper line on the dipstick.

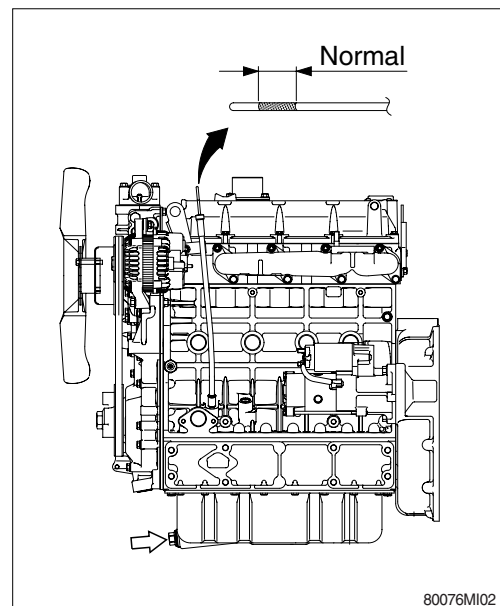

### 3) REPLACING ENGINE OIL FILTER CARTRIDGE

※ **Be sure to stop the engine before replacing filter cartridge.**

- (1) Remove the oil filter cartridge with the filter wrench.
- (2) Apply a slight coat of oil onto the new cartridge gasket.
- (3) To install the new cartridge, screw it in by hand. Over tightening may cause deformation of rubber gasket.
- (4) After the new cartridge has been replaced, the engine oil normally decrease a little. Thus see that the engine oil does not leak through the seal and be sure to read the oil level on the dipstick. Then, replenish the engine oil up to the specified level.

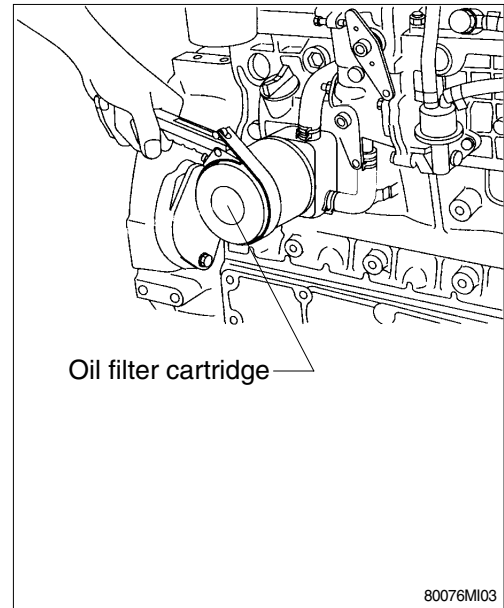

### 4) CHECK RADIATOR COOLANT

- (1) To check coolant level open the rear door. Check to see that the coolant level lies between **FULL** and **LOW**.

- (2) If coolant level is too low, fill clean water into the radiator.

- (3) Replace gasket of radiator cap when it is damaged.

※ **Hot coolant can spray out if radiator cap is removed while engine is hot. Remove the cap after the engine has cooled down.**

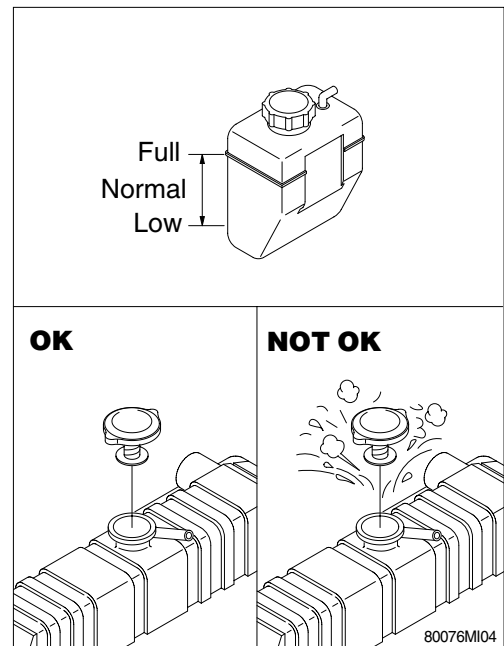

## 5) FLUSHING AND REFILLING OF RADIATOR

### (1) Change coolant

**▲** Avoid prolonged and repeated skin contact with used antifreeze. Such prolonged, repeated contact can cause skin disorders or other bodily injury.

Avoid excessive contact—wash thoroughly after contact.

Keep out of reach of children.

※ Protect the environment : Handling and disposal of used antifreeze can be subject to federal, state, and local law regulation.

Use authorized waste disposal facilities, including civic amenity sites and garages providing authorized facilities for the receipt of used antifreeze.

If in doubt, contact your local authorities for guidance as proper handling of used antifreeze.

**▲** Wait until the temperature is below 50°C (120°F) before removing the coolant system pressure cap.

Failure to do so can cause personal injury from heated coolant spray.

- ① Stop the engine and let cool down.
- ② To drain the coolant, open the radiator drain valve and remove the radiator cap. Then radiator cap must be removed to completely drain the coolant. And open the drain cock.
- ③ After all coolant is drained, close the drain valve.
- ④ Fill with clean water and cooling system cleaner.

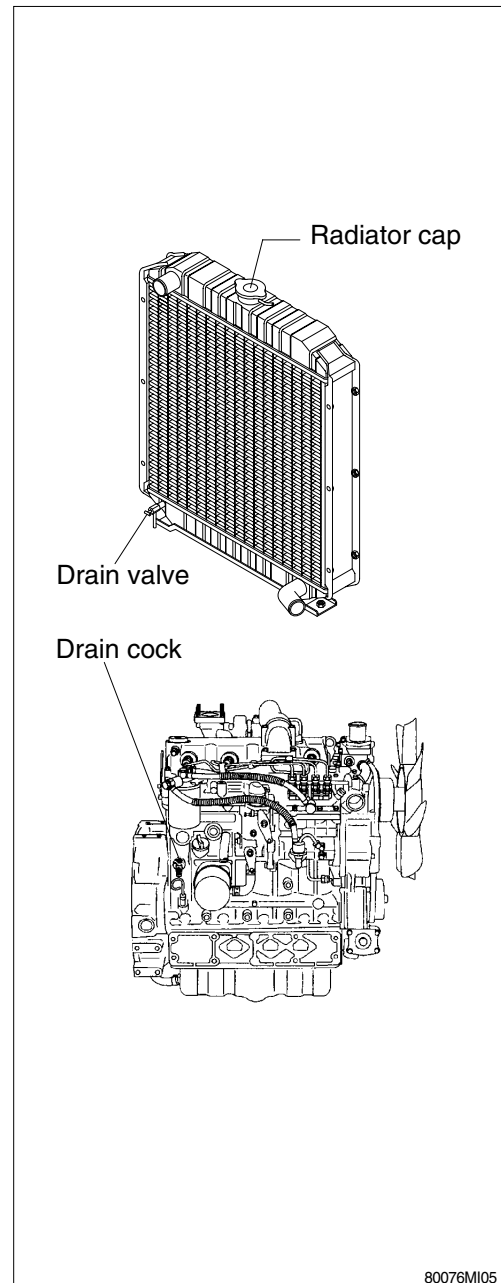

### (2) Flushing of cooling system

- ① Fill the system with a mixture of sodium carbonate and water (Or a commercially available equivalent).

※ Do not install the radiator cap. The engine is to be operated without the cap for this process.

- ② Operate the engine for 5 minutes with the coolant temperature above 80°C (176°F). Shut the engine off, drain the cooling system.

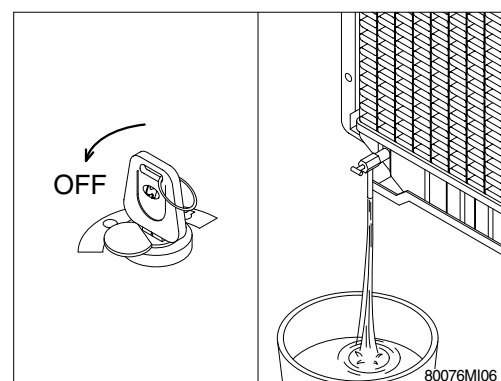

- ③ Fill the cooling system with clean water.
- ※ **Be sure to vent the engine and aftercooler for complete filling.**
  - ※ **Do not install the radiator cap or the new coolant filter.**

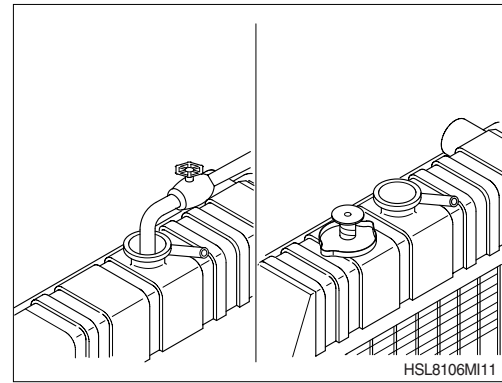

- ④ Operate the engine for 5 minutes with the coolant temperature above 80°C(176°F). Shut the engine off, and drain the cooling system.
- ※ **If the water being drained is still dirty, the system must be flushed again until the water is clean.**

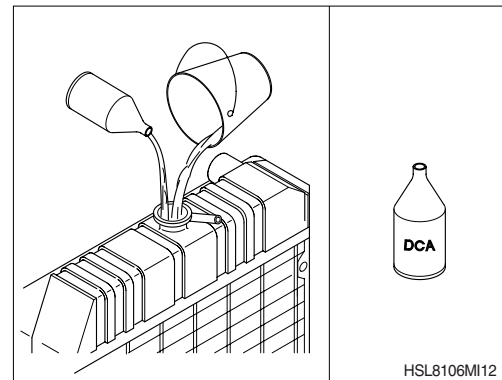

### (3) Cooling system filling

- ① Use a mixture of 50 percent water and 50 percent ethylene glycol antifreeze to fill the cooling system.
- Coolant capacity : 10.3 l (2.7U.S.gallons)
  - ※ **Use the correct amount of DCA4 corrosion inhibitor to protect the cooling system.**
- ② Install the radiator cap. Operate the engine until it reaches a temperature 80°C (176°F), and check for coolant leaks.
- Check the coolant level again to make sure the system is full of coolant.
- ※ **Do not start engine without coolant.**
  - ※ **Securely tighten radiator cap. If the cap is loose or improperly fitted, water may leak out and the engine could overheat.**

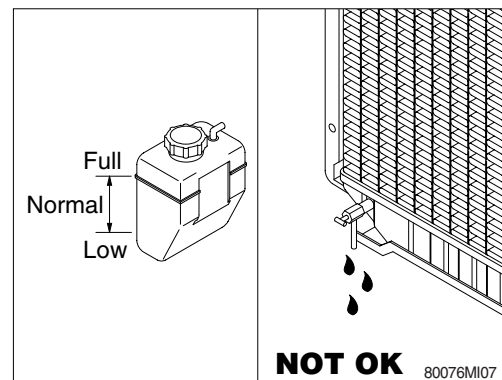

## 6) CLEAN RADIATOR AND OIL COOLER

Check, and if necessary, clean and dry outside of radiator and oil cooler. After working in a dusty place, clean radiator more frequently.

- (1) Visually inspect the radiator for clogged radiator fins.
- (2) Use compressed air (2kgf/cm<sup>2</sup> or lower) to blow the dirt and debris from the fins.  
Blow the air in the opposite direction of the fan air flow.
- (3) Visually inspect the radiator for bent or broken fins.  
※ If the radiator must be replaced due to bent or broken fins which can cause the engine to overheat, refer to the manufacturer's replacement procedures.
- (4) Visually inspect the radiator for core and gasket leaks.

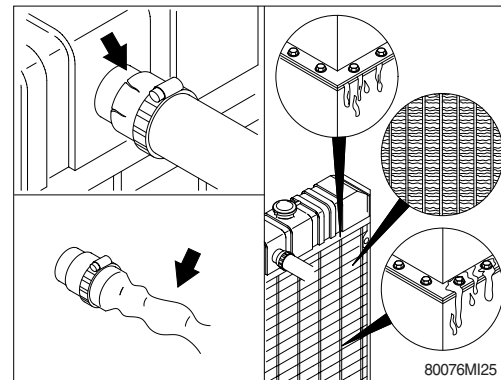
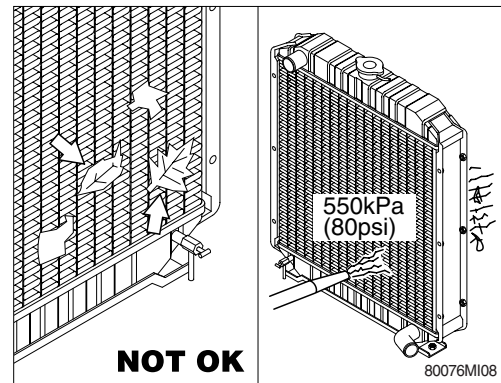

## 7) FAN BELT TENSION

- (1) Measure the deflection(A), depressing the belt halfway between the fan drive pulley and the alternator pulley at specified force(98N, 10kgf, 22lbs).
- (2) If the measurement is not within the specifications, loosen the alternator mounting screws(B) and relocate the alternator to adjust.  
· Deflection(A) : 10~12mm
- (3) Do not allow oil to deposit on the V-belt because the V-belt slips and is easily elongated.  
Replace the damaged V-belt.

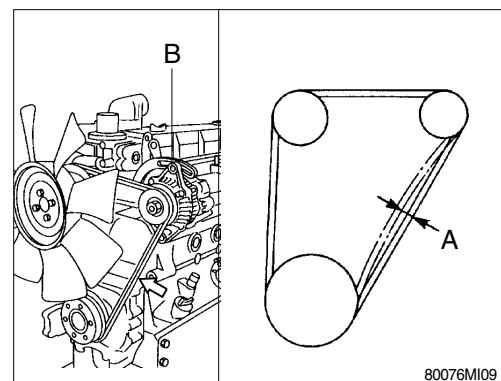

## 8) INSPECTION OF COOLING FAN

- ▲ Personal injury can result from a fan blade failure. Never pull or pry on the fan. This can damage the fan blade and cause fan failure.
- ※ A visual inspection of the cooling fan is required daily.  
Check for cracks and bent or loose blades.

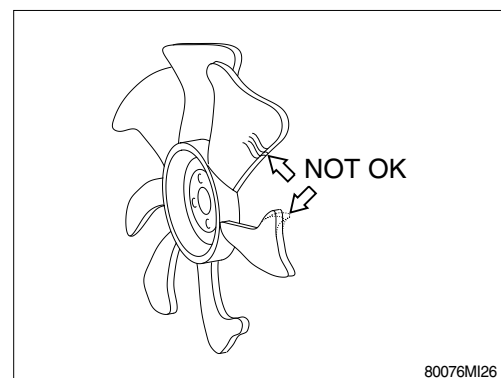

## 9) CLEANING OF AIR CLEANER

### (1) Primary element

- ① Unlock the latches and remove the element.
  - ② Clean the inside of the body.
  - ③ Clean the element with pressurized air.
    - Remove the dust inside of the element by the pressurized air (Below  $3\text{kgf/cm}^2$ , 40psi) forward and backward equally.
  - ④ Inspect for cracks or damage of element by putting a light bulb inside of the element.
  - ⑤ Insert element and lock the latches.
- ※ **When the air cleaner warning lamp is ON, clean the primary element.**
  - ※ **The primary element should be replaced if the warning lamp is ON after installation of a clean primary element, or if the exhaust smoke is still black.**
  - ※ **Replace the primary element after 4 times cleanings.**

### (2) Safety element

- ※ **The safety element should be replaced at the time the primary element is replaced.**
- ※ **Always replace the safety element. Never attempt to reuse the safety element by cleaning the element.**

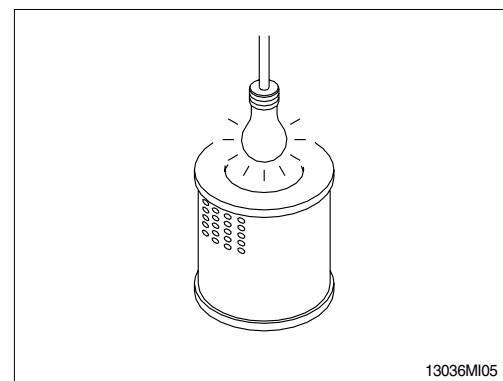
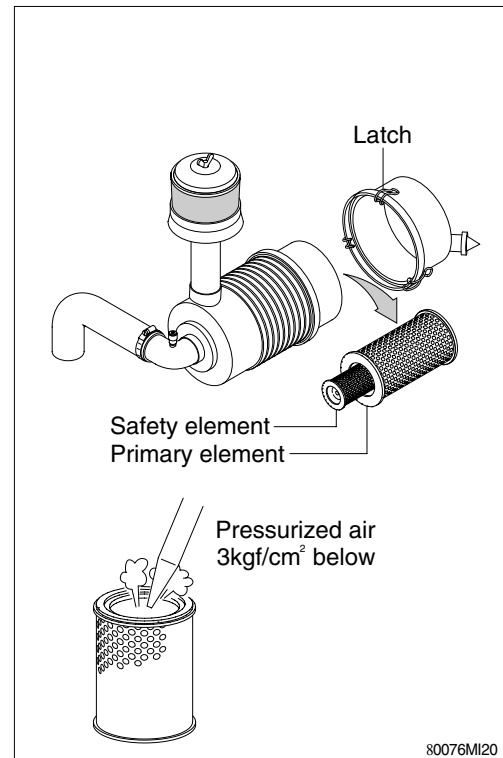

## 10) SPARK ARRESTING MUFFLER

※ Clean the spark arresting muffler after every 250 hours of operation.

※ Another person available is needed to hold a block of wood over the tail pipe of the spark arresting muffler while clean it.

- (1) Remove the pipe plug from the spark arresting muffler.
- (2) Turn the key to START for 30 seconds while the other person is holding the block of wood over the outlet pipe of the spark arresting muffler.
- (3) Turn the key to OFF.
- (4) Install the plug in the spark arresting muffler.

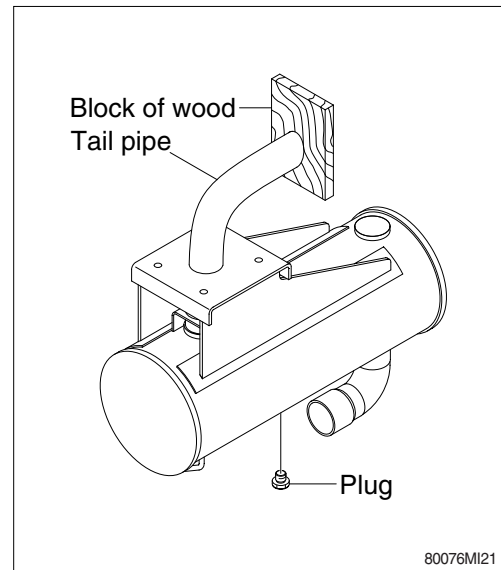

## 11) FUEL TANK

(1) Fill fuel fully when system the operation to minimize water condensation and check it with fuel gauge before starting the machine.

※ Be sure to LOCK the cap of fuel tank.

▲ Stop the engine when refueling.

All lights and flames shall be kept at a safe distance while refueling.

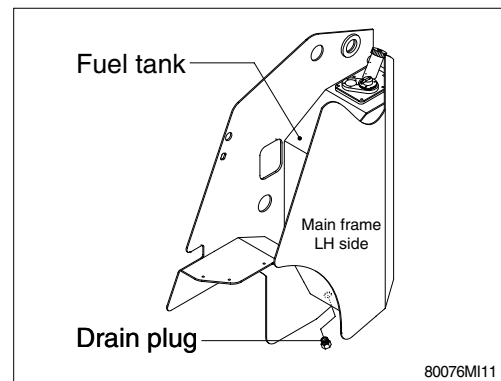

## 12) REPLACEMENT OF FUEL FILTER

※ Water and dust in fuel are collected in the filter cartridge. So, replace the filter every 500 hours service.

- (1) Remove the used filter with filter wrench.
- (2) Apply a thin film of fuel to the surface of new filter gasket before screwing on.
- (3) Then tighten enough by hand.
- (4) Operate the top of the fuel filter manually up and down several times.
- (5) Start engine and check for fuel leakage.

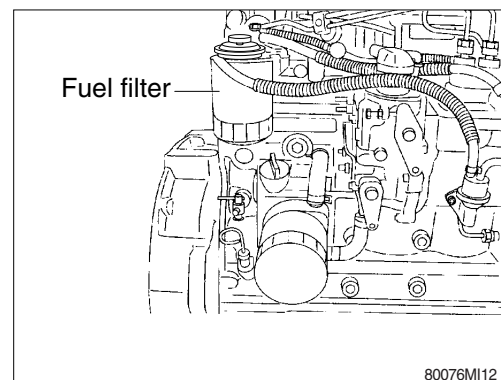

### 13) BLEEDING OF FUEL SYSTEM

- (1) Operate the top of the fuel filter manually up and down several times until clear fuel is visible.
- (2) Operate the engine at low idle and inspect for leaks at the filter and the drain plug.

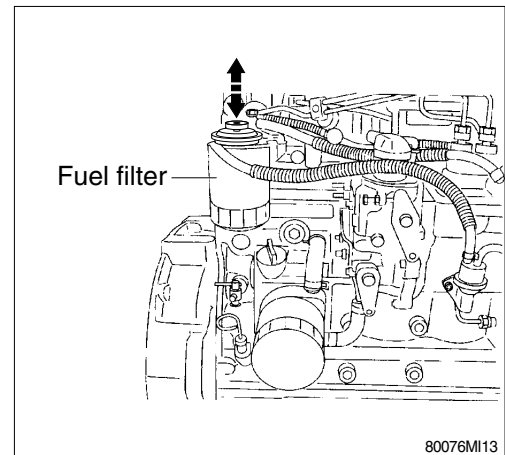

### 14) FUEL WATER SEPARATOR

※ **When the float of separator meets the drain level, drain water.**

- (1) Close the fuel cock.
- (2) Loosen the retainer ring and remove the cup. Throw out the collected water and dirt.
- (3) Put the float and the coil spring into the cup and tighten the retainer ring. If in doubt, consult your nearest authorized Hyundai dealer.

※ **Do not smoke or have any other open flame near the engine while bleeding the fuel system..**

※ **Be sure to carefully wipe away any water drained out in this manner, because the fuel mixed in the water might be ignited and result in a fire.**

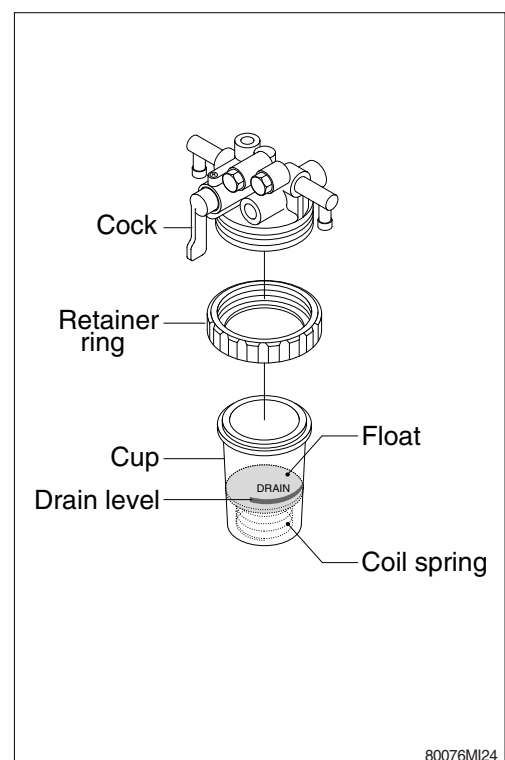

## 15) HYDRAULIC OIL LEVEL CHECK

- (1) Lower the bucket on the ground as the picture right.  
Stop the engine and then level for about 5 minutes.
- (2) Check the oil level at the level gauge of the hydraulic oil tank.
- (3) The level gauge should indicate the middle position.

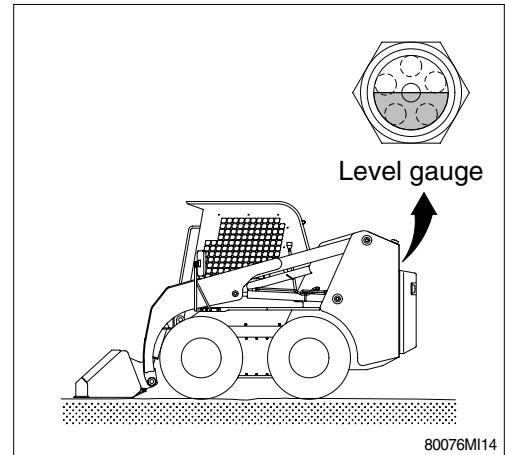

## 16) CHANGE THE HYDRAULIC OIL AND FILTER

- (1) Lower the boom ground any attachment, and shut the engine off.
- (2) Place a receptacle under the drain plug. Remove the magnetic drain plug from the bottom of the hydraulic oil tank. Clean loose particles from the plug.  
Allow tank to drain completely into receptacle.
- (3) Remove old hydraulic return filter element and install the new filter element by hand.
- (4) Reinstall magnetic drain plug into hydraulic tank.
- (5) Remove the hydraulic tank fill cap and fill the tank with : IOS VG 46 oil until it reaches the proper level.  
Capacity : 56 l (14.8U.S.gal)
- (6) Install fill cap.
- (7) Check for hose or fitting leaks.

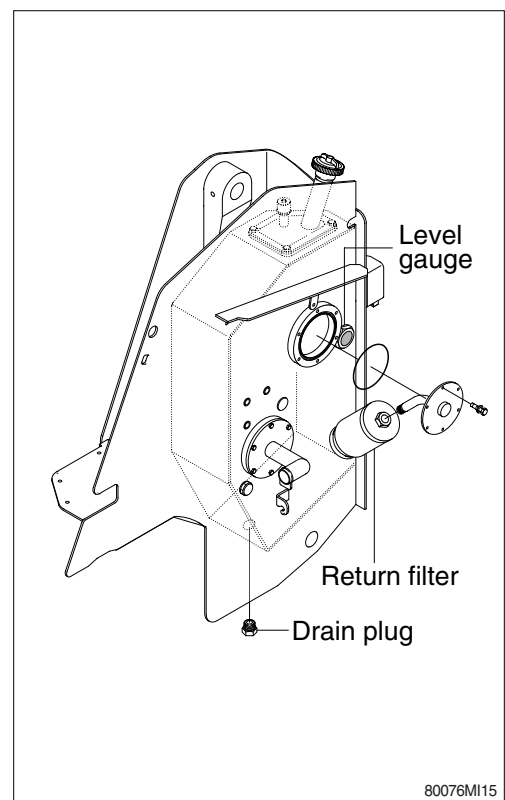

## 17) REPLACE OF HYDRAULIC STRAINER

- (1) Loosen the strainer.
- (2) Pull out the hydraulic strainer.
- (3) Install the new strainer and tighten by hand.

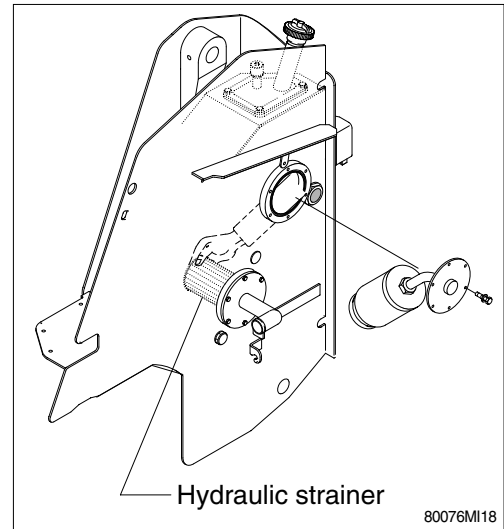

## 18) CLEANING HYDRAULIC AIR BREATHER

- (1) Loosen the screw and remove the cover.
- (2) Pull out the filter element.
- (3) Clean the filter element

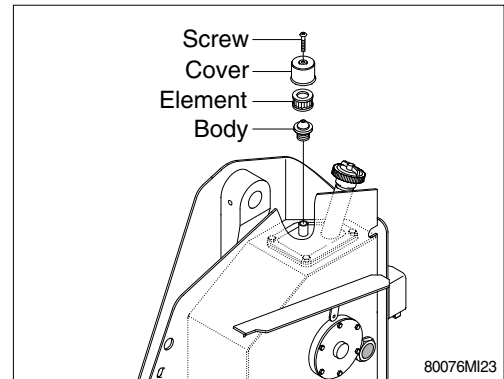

## 19) TIRE PRESSURE

(1) Inappropriate tire pressure is a primary cause for tire damage. Insufficient tire pressure will damage internal carcass of tire. Repeated excessive bending will damage or break the carcass. Excessive pressure will also cause premature damage of tire.

(2) Recommended tire pressure(When tire is cooled)

Size	Pressure
12.0×16.5	5.25kg/cm <sup>2</sup> (75psi)

(3) Continuous operation will produce heat and increase pressure on tire. But such phenomenon was already taken into account when designing a tire. Do not try to remove normally increased air because tires may be crushed or overinflated.

(4) The three major causes for excessive heat and pressure of tire are insufficient pressure, excessive load and overspeed. Avoid excessive load and overspeed in order to keep tires in good shape.

**▲ Do not inflate tires using flammable gases or alcohol injector.**

**This cause explosion or personal injury.**

**▲ Inflate tires at the pressure level recommended by the manufacturer, and check periodically pressure and wear of tires.**

**▲ When replacing the inflated tire, do not stand near the tire.**

**※ Check the tire when the tire is at normal temperature and the machine is not loaded.**

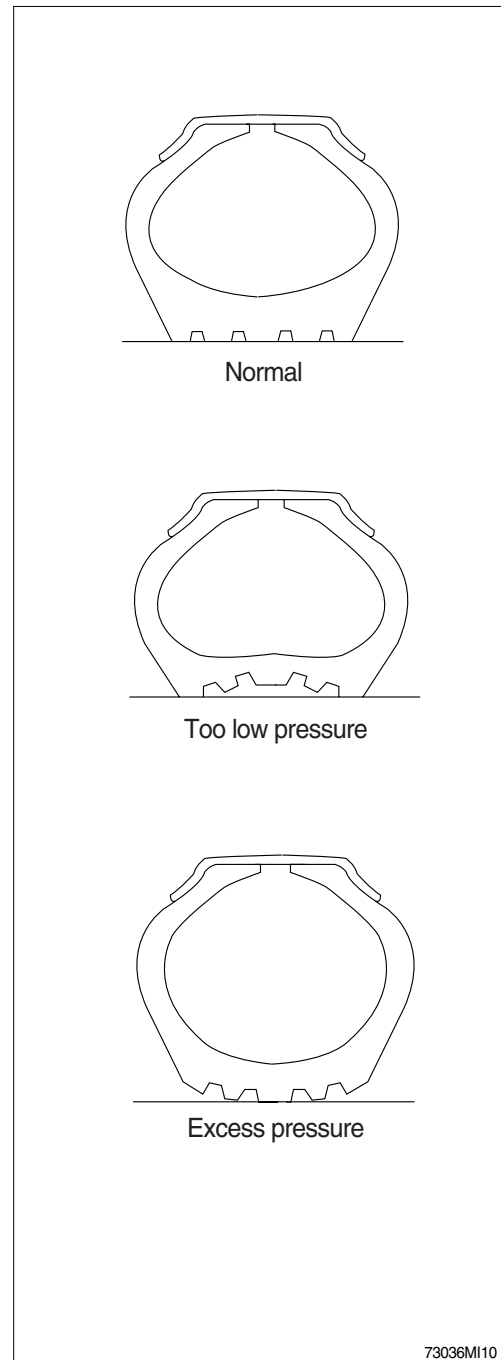

## 20) TIRE ROTATION

- (1) The front rear tires wear at different rates.  
To compensate, move the front tires to the rear and the rear tires to the front when wear is first noticed.
- (2) If two tires become worn more than the other two, put the two worn tires on the same side.  
Replace excessively worn tires.
- (3) When new tires are installed, always keep tires of the same size on the same side of the loader.  
Two different size tires on the same side of the loader cause drive chain wear, tire wear, and loss of power.

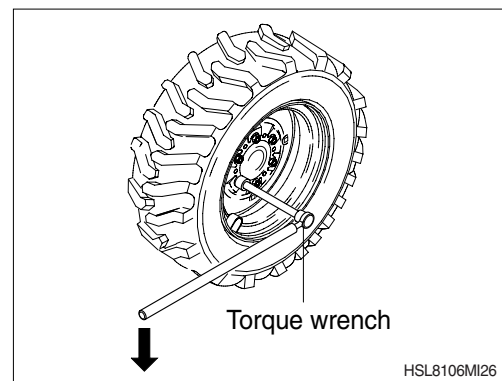
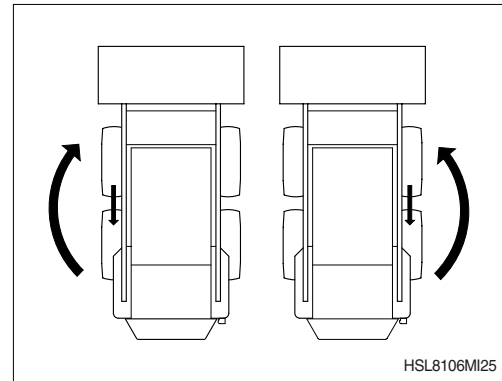

## 21) WHEEL LUG NUT TORQUE

- (1) Check torque on all wheels to prevent shearing of the wheel studs and rim damage. Replace damaged rims.
- (2) Torque wheel nuts in sequence to  $21.9 \pm 5 \text{kgf} \cdot \text{m}$   
( $158 \pm 36 \text{lb} \cdot \text{ft}$ )

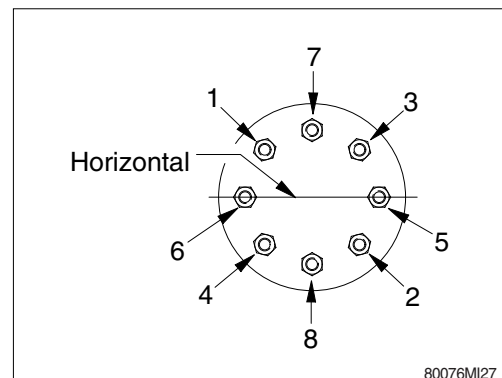

## 22) STORING TIRES AFTER REMOVAL

As basic rule, store the tires in a warehouse which unauthorized persons cannot enter. If the tire are stored outside, always erect a fence around the tires and put up **No Entry** and other warning signs that even young children can understand. Stand the tire on level ground, and block it securely so that it cannot roll or fall over. If the tire should fall over, get out of the way quickly. The tires for construction equipment are extremely heavy, so trying to hold the tire may lead to serious injury.

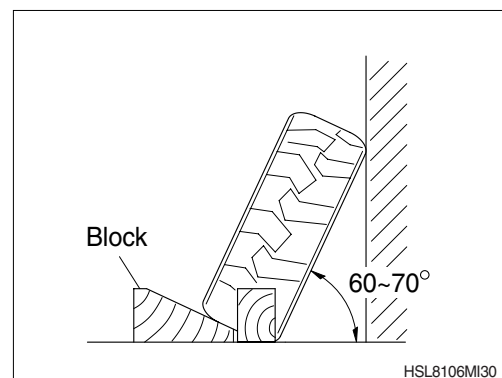

## 23) FINAL DRIVE CHAIN CASE OIL

### (1) Level check

- ① Lower the boom ground any attachment, and shut the engine off.
- ② Remove the check/fill plug between the two tires.
- ③ If oil can be detected by inserting a finger through the check/fill plug opening, the level is satisfactory. If not, add 15W-40(API CH-4) oil as required through the same plug opening.
- ④ Install the check/fill plug.
- ⑤ Repeat the procedure for other drive housing.

### (2) Oil change

- ① Lower the boom ground any attachment, and shut the engine off.
- ② Remove the check/fill plug and the drain plug and allow oil to drain from the housing into a receptacle.
- ③ Install the drain plug.
- ④ Add 15W-40(API CH-4) oil through the check/fill plug opening to the level of the plug opening. Capacity for each drive housing is 9.2 liters.
- ⑤ Install the check/fill plug. Repeat the procedure for the other drive housing.

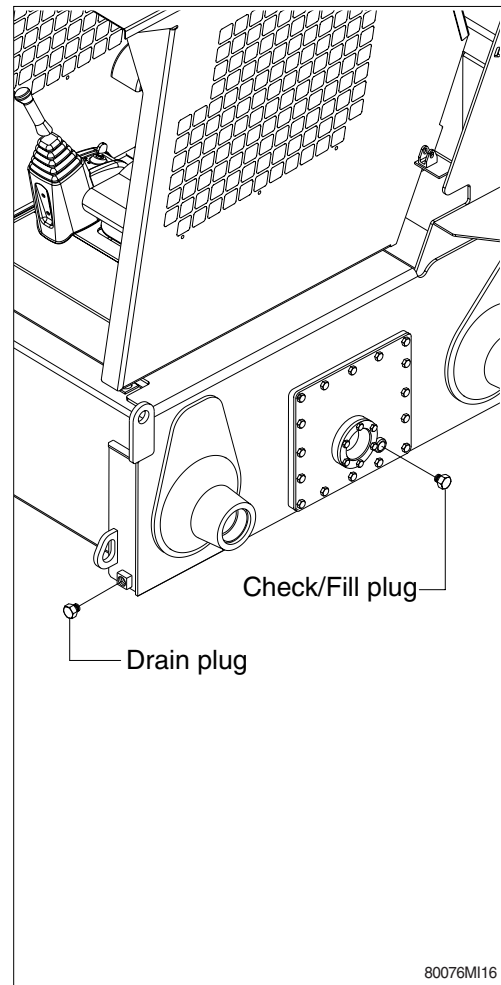

## 24) MAINTENANCE OF WORK EQUIPMENT

- (1) Lubricate to each pin of working device.  
Lubricate the grease to grease nipple in accordance with lubrication intervals.

No.	Description	Qty
1	Boom frame connection pin	2
2	Boom attachment holder connection pin	2
3	Boom cylinder-frame connection pin	2
4	Boom cylinder-boom connection pin	2
5	Tilt cylinder-boom connection pin	2
6	Tilt cylinder-attachment holder connection pin	2

※ **Shorten lubricating interval when working in the water or dusty place.**

- (3) Check for wear and tear of work equipment pins and bushings.  
(4) Check for damage of boom and attachment holder.

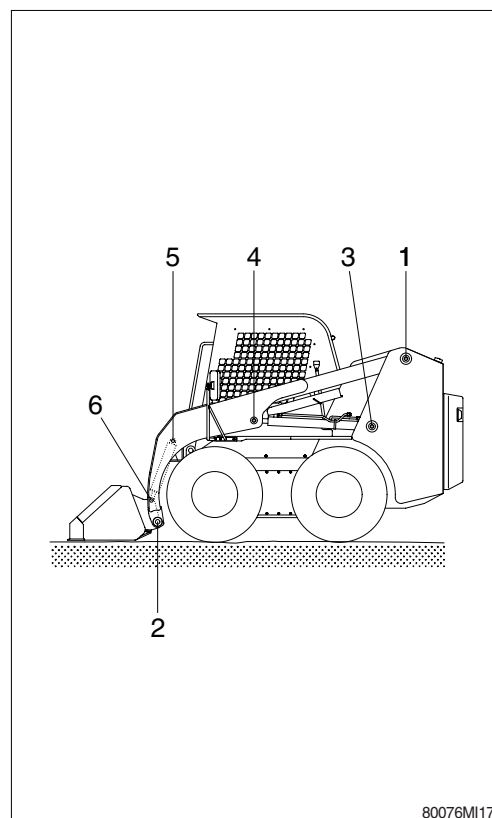

## 8. ELECTRICAL SYSTEM

### 1) WIRING, GAUGES

Check regularly and repair loose or malfunctioning gauges when found.

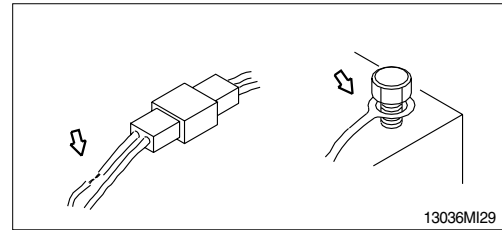

### 2) BATTERY

**▲ BATTERIES EMIT EXPLOSIVE GAS.** Do not smoke or have open flames or sparks in battery charging areas or near batteries. An explosion can result and cause injury or death.

Hydrogen gas is produced during normal battery operation. Hydrogen can explode if flames, sparks, or lighted tobacco are brought near the battery. When charging or using a battery in an enclosed space, always provide ventilation and shield your eyes. Wear safety glasses when working around batteries.

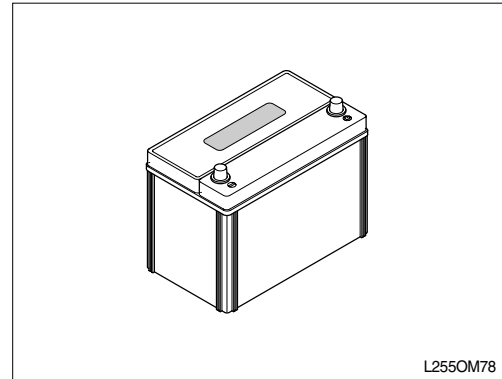

#### (1) REMOVING

Remove the lead from the ground side (Normally the (-) terminal side) of the battery. It is dangerous to let a tool, etc., touch the (+) terminal and the body at the same time, since this causes a spark.

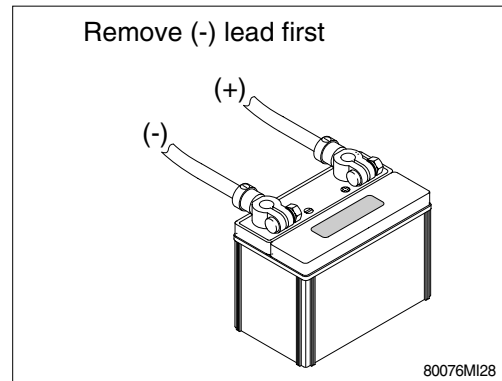

#### (2) INSTALLING

When remounting, connect the ground connection last.

**▲ Do not allow tools to touch the (+) terminal and the body of the machine at the same time. This can cause sparking and explosion. Dispose of old battery in locally approved manner.**

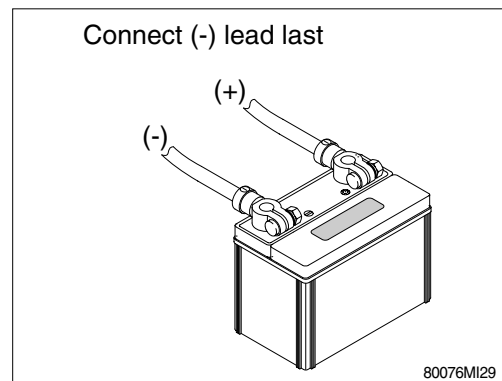

### (3) Welding repair

Before start to welding, follow the below procedure.

- ① Shut off the engine and remove the starting switch.
  - ② Disconnect ground cable from battery by master switch.
  - ③ Before carrying out any electric welding on the machine, the battery cables should be disconnected and the connectors pulled out of the electronic control units.
  - ④ Connect the earth(ground) lead of the welding equipment as close to the welding point as possible.
- ※ Do not weld or flame cut on pipes or tubes that contain flammable fluids. Clean them thoroughly with nonflammable solvent before welding or flame cutting on them.
- ▲ Do not attempt to welding work before carry out the above.  
If not, it will caused serious damage at electric system.

