

4. OPERATION

1. SUGGESTION FOR NEW MACHINE

- 1) It takes about 100 operation hours to enhance its designed performance.
- 2) Operate according to below three steps and avoid excessive operation for the initial 100 hours.

Service meter	Load
Until 10 hours	About 60%
Until 100 hours	About 80%
After 100 hours	100%

※ **Excessive operation may deteriorate the potential performance of machine and shorten lifetime of the machine.**

3) Be careful during the initial 100hours operation.

- (1) Check daily for the level and leakage of coolant, engine oil, hydraulic oil and fuel.
- (2) Check regularly the lubrication and fill. Grease daily all lubrication points.
- (3) Tighten bolts.
- (4) Warm up the machine fully before operation.
- (5) Check the gauges occasionally during the operation.
- (6) Check if the machine is operating normally during operation.

4) Replace followings after initial 50 hours of operation.

Checking items	Service
Engine oil and filter	Replace
Hydraulic oil and return filter	

Avoid excessive operation for initial 100 hours

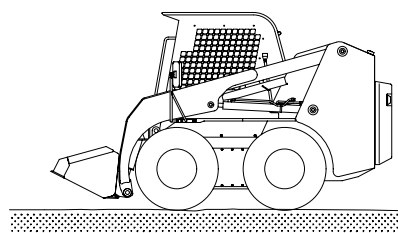

80074OP01

2. CHECK BEFORE STARTING THE ENGINE

- 1) Look around the machine and under the machine to check for loose nut or bolts, collection of dirt, or leakage of oil, fuel or coolant and check the condition of the work equipment and hydraulic system. Check also loosen wiring, and collection of dust at places which reach high temperature.
※ **Refer to the daily check on the chapter 6, maintenance.**
 - 2) Adjust seat to fit the contours of the operator's body for the pleasant operation.
 - 3) Make sure that the machine is equipped with a lighting system that is adequate for the job conditions. Ensure that all lights are in proper working condition.
 - 4) Adjust the rear view mirror.
 - 5) Make sure that there are no personnel in the area before you start the engine. Make sure that there are no personnel in area before you move the machine. Make sure that there are no personnel on the machine, underneath the machine, or around the machine.
- ▲ If a warning tag is attached to the starting switch or to the controls, do not start the engine. Also, do not move any controls.**
- ▲ Do not start the engine unless you are in the seat with the seat belt fastened around you and the seat bar down. Death or serious injury could result if the belt is not securely fastened.**

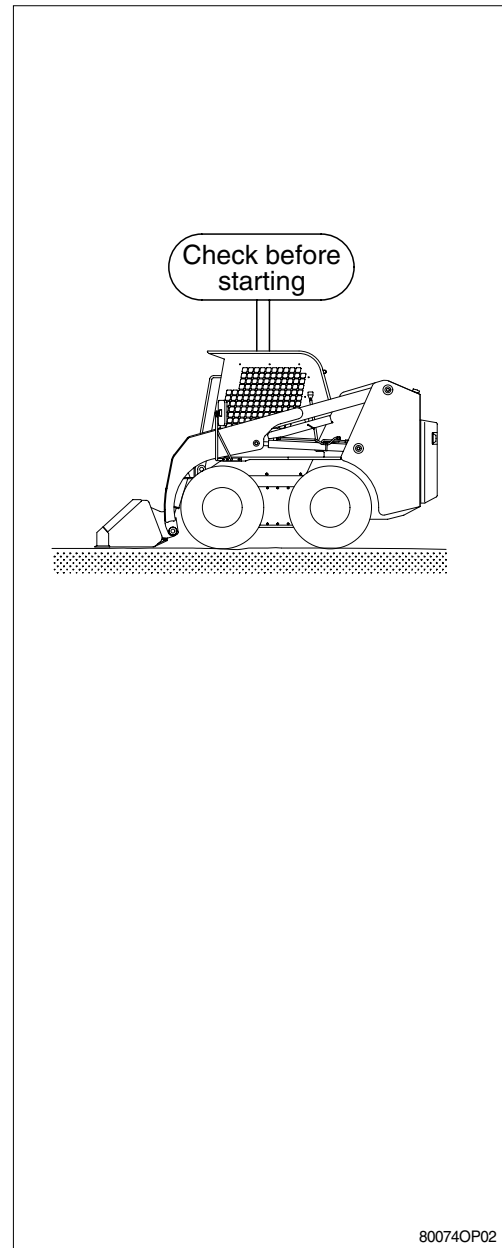

3. NORMAL STARTING

1) WALK AROUND INSPECTION

- (1) Check and add engine oil if required.
- (2) Check cooling system for fluid and airflow.
- (3) Check hydraulic oil level, add oil if required.
- (4) Walk around machine and check for leakage, damaged or missing parts, and proper tire inflation. Make necessary repairs before operating.

2) NORMAL STARTING ENGINE

- (1) Using hand holds, enter the loader and adjust the operator's seat for comfortable operation.
- (2) Fasten seat belt.
- (3) Place the control levers and pedals into NEUTRAL position and apply the seat bar down.
- (4) Move the throttle lever forward about 1/4 of the way.
- (5) Turn the start switch to ON position, and wait the preheater pilot lamp(4) OFF.
- (6) Turn and hold the start switch clockwise to the start position. Do not crank the starter for longer than 15 seconds.
- (7) Check engine oil pressure warning lamp(2) and battery charging warning lamp(1). They should light during starting and turn OFF when engine is running.
- (8) Once the engine is running, release the start switch. The switch will return to the ON position.
- (9) Allow the engine to warm up for five minutes.

※ The battery charge warning lamp(1) is turned ON when the alternator is not producing sufficient current.

The engine oil pressure warning lamp(2) indicated low engine oil pressure. The hydraulic oil temperature warning lamp(3) is turned ON when the hydraulic oil in the reservoir is overheated. If any of these warning lamps turn ON while the engine is running, shut off the engine immediately and determine the cause.

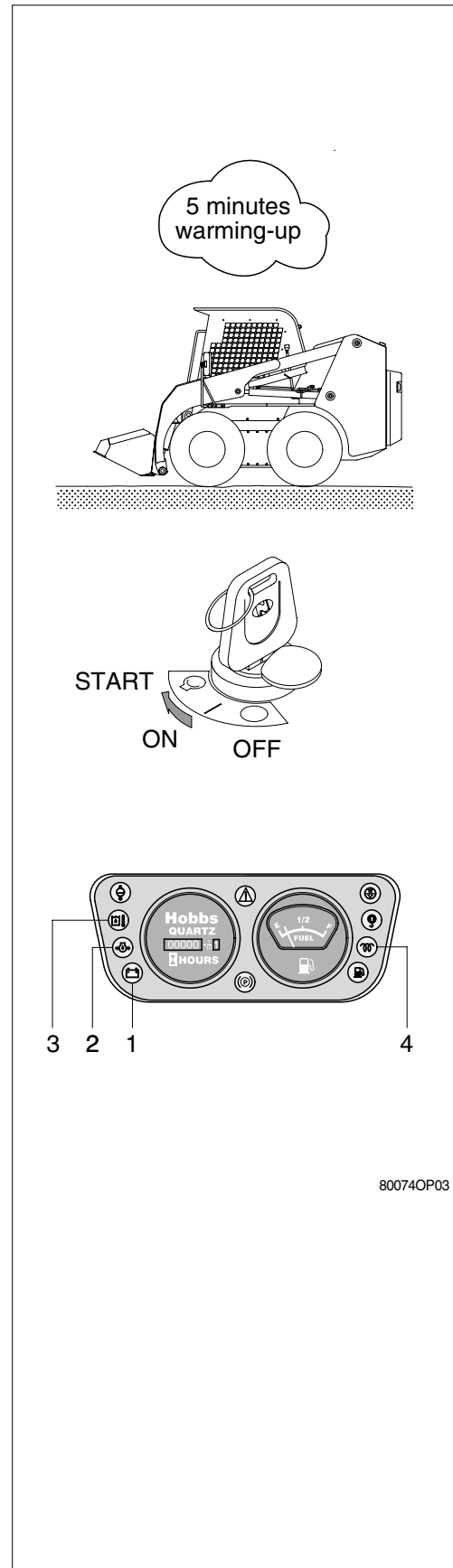

4. STARTING ENGINE IN A COLD WEATHER

Low temperature causes battery performance to lower and viscosity of lubricating oil to increase, both of which make the engine starting more difficult. In cold season, the engine is started in the following way.

- 1) Set throttle lever to maximum speed position.
- 2) Turn the start switch to ON position, and wait the preheater pilot lamp OFF.
- 3) When the preheater pilot lamp is turned ON, the timer starts counting the specified time while the heater lamp is lit. After 5~20 seconds of preheating, the timer turns off the air heater pilot lamp to indicate that preheating is completed.
- 4) When the preheater pilot lamp goes out, turn the start switch at START position.
- 5) If the engine does not start within 15 seconds, repeat PREHEAT operation.
※ **Do not use the starter motor continuously more than 15 seconds.**
- 6) As soon as it comes to normal operation, return the start switch to ON position.
- 7) Return the throttle lever to idling position and warm up for 10 to 15 minutes.

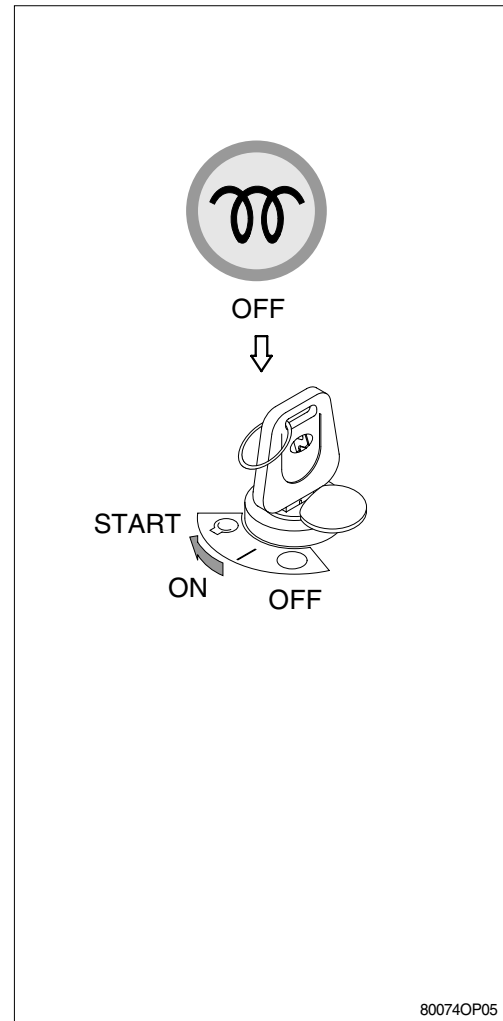

80074OP05

5. JUMP STARTING

Jump starting or battery replacement is required when the battery is discharged to a point where the battery will not turn the starter.

▲ To avoid personal injury when jump starting the loader with another machine, be sure the machine are not touching. Keep sparks, flames, and lit cigarettes away from the battery. Lead acid batteries generate explosive gases when charging or when the engine is running. Wear safety glasses when working near batteries.

- 1) To jump start, be sure the battery fluid levels are correct and vent caps are tight.
Place a damp cloth over the battery vent caps.
- 2) The booster battery must be a 12volt type.
The machine used for jump starting must have a negatively grounded electrical system.
- 3) Connect the positive (+) jumper cable to the positive post of the discharged battery.
- 4) Connect the other end the same jumper cable to the positive (+) terminal of the booster battery.
- 5) Connect one end of the second jumper cable to the negative (-) post of the booster battery.
- 6) Make the final jumper cable connection to the engine block or the furthest ground point away from the battery.
- 7) Follow steps in **Normal starting**.
- 8) Remove jumper cables in the reverse order of their connection(i.e. negative cable connection first, etc...)

Connection of booster cable

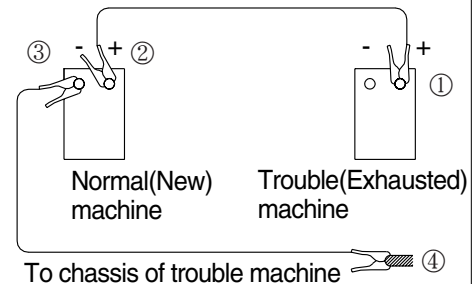

Connection order : ①→②→③→④

Disconnection of booster cable

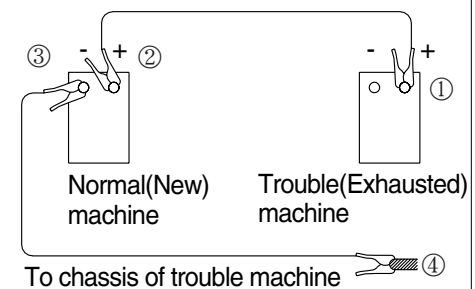

Disconnection order : ④→③→②→①

HSL8104OP38

6. TO STOP THE ENGINE

- ※ If the engine is abruptly stopped before it has cooled down, engine life may be greatly shortened. Consequently, do not abruptly stop the engine apart from an emergency.
- ※ If there are problems in the warning indicator panel, stop the engine immediately and correct problem as required.
 - 1) Place the control lever and foot pedal in neutral.
 - 2) Run the engine at low idling speed for about 5minutes.
 - 3) Turn the start switch to the OFF position.
 - 4) Remove the start switch to prevent other people using the machine.

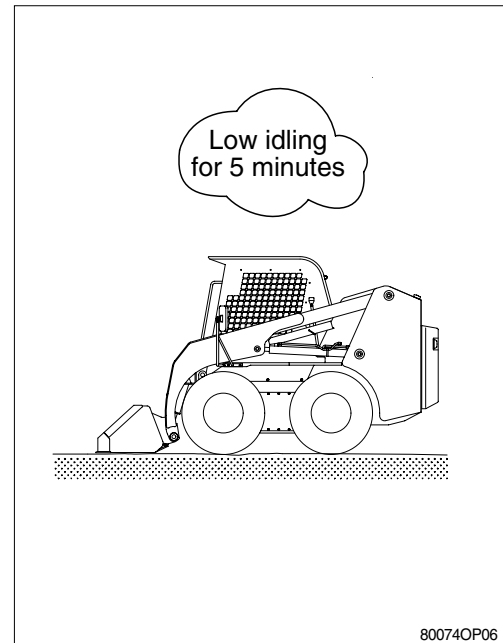

7. WARMING-UP OPERATION

※ The most suitable temperature for the hydraulic oil is about 50°C (112°F)

It can cause serious trouble in the hydraulic system by sudden operation when the hydraulic oil temperature is below 25°C (77°F).

The temperature must be raised to at least 25°C (77°F) before starting work.

- 1) Below 0°C(32°F), run the engine at 1/2 throttle for 10 minutes with the control levers in the NEUTRAL position.
- 2) Increase the engine speed to 3/4 throttle and move the control levers to 1/2 forward.
- 3) Move the machine at no load for one minute or until the travel motor runs normally.

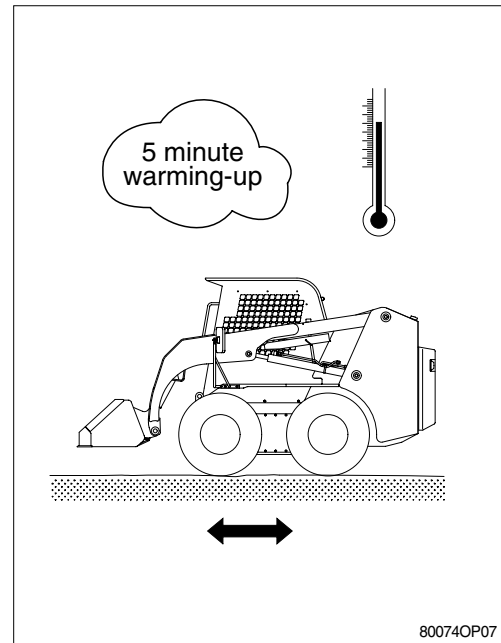

8. OPERATION OF THE WORKING DEVICE

※ Confirm the operation of control lever and working device.

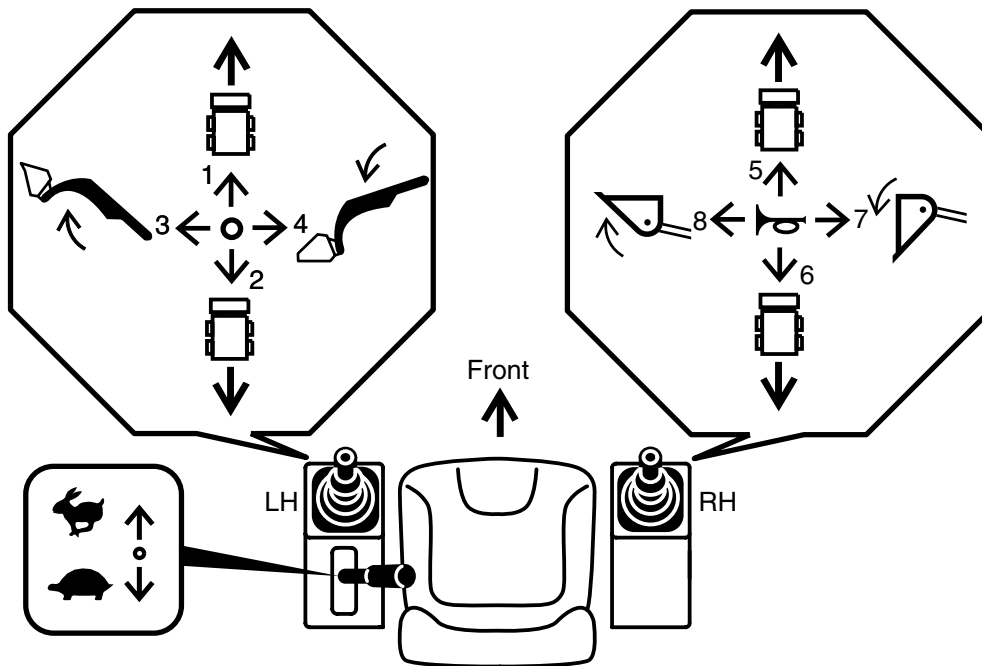

80074OP04

※ **Left control lever**

- 1 Forward traveling(LH)
- 2 Backward traveling(LH)
- 3 Boom raise
- 4 Boom lower

※ **Right control lever**

- 5 Forward traveling(RH)
- 6 Backward traveling(RH)
- 7 Bucket dump
- 8 Bucket roll back

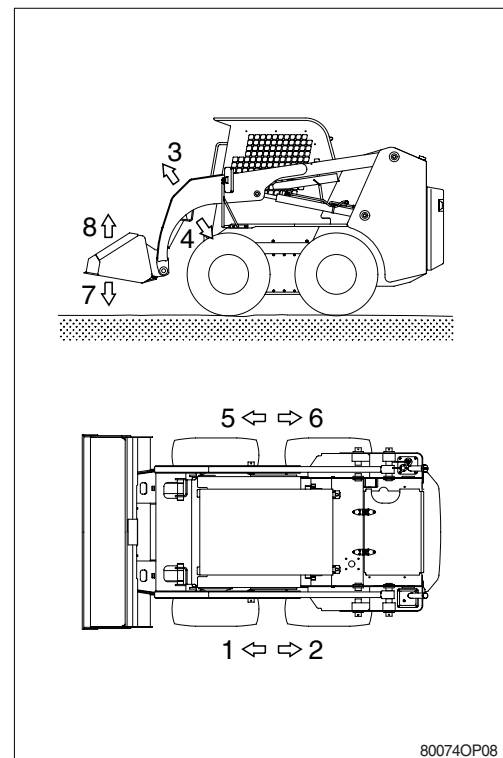

80074OP08

9. MACHINE OPERATION

1) STARTING

- (1) Push the throttle lever forward to raise the engine speed.
- (2) Operate the control lever to raise the bucket to 20~30cm(1ft) above the ground.
- (3) Operate the loader at high engine speed.

2) STRAIGHT FORWARD

Push both control levers forward from the centered(Neutral) position the same distance. The further the levers are away from the neutral position, the faster the travel speed.

3) STRAIGHT BACKWARD(Reverse)

Pull both control levers backward from the centered(Neutral) position the same distance. The further the levers are away from the neutral position, the faster the travel speed.

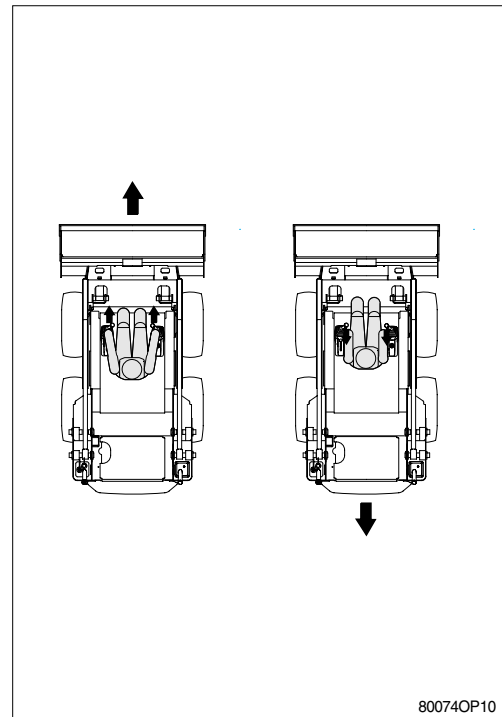

4) SLOW TURN

Varying shift distances of the left and right control levers during forward or backward traveling makes the machine slowly turn to the side where the shift distance is smaller.

The greater the difference between the shift distance of the two levers, the smaller the turning radius. The smaller the difference, the greater the turning radius.

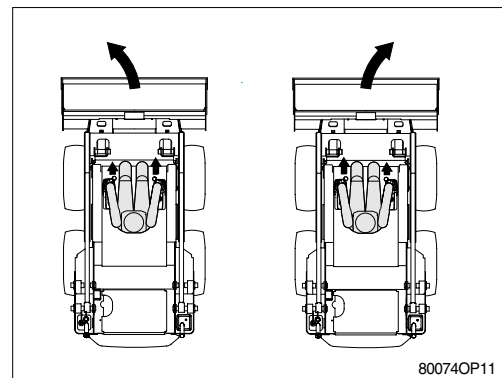

5) PIVOT TURN

Operating only the left one of the two control levers makes the machine turn with the right tires as the center. Operating the right lever causes a left turn around the left tires.

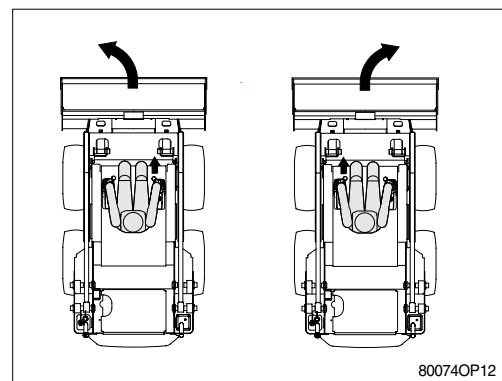

6) SPIN TURN

Operating the left and right control levers in the opposite directions makes the left and right tires rotate in reverse directions to cause the machine to turn around its center of gravity.

- ▲ To respond immediately to any situation involving the boom, always keep both hands on the control levers. Serious injury or death will result if the boom is not controlled.

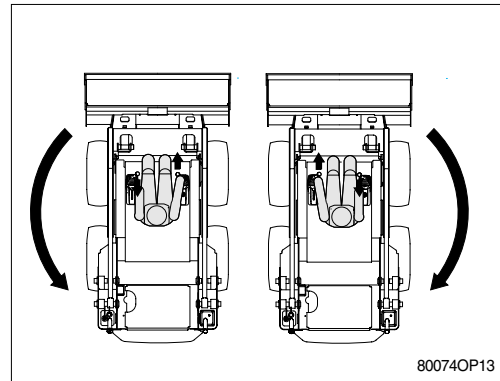

7) SLOP TRAVELING

The engine angularity limits are 20 degree.
Do not operate by more than the engine limits in any case

(1) Loaded - Bucket upgrade

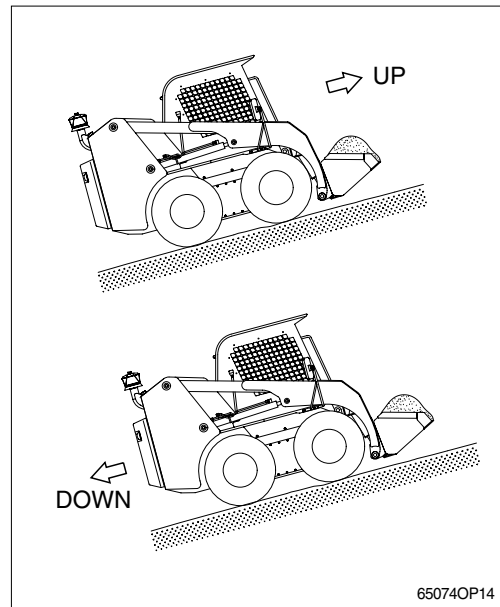

(2) Unloaded - Bucket downgrade

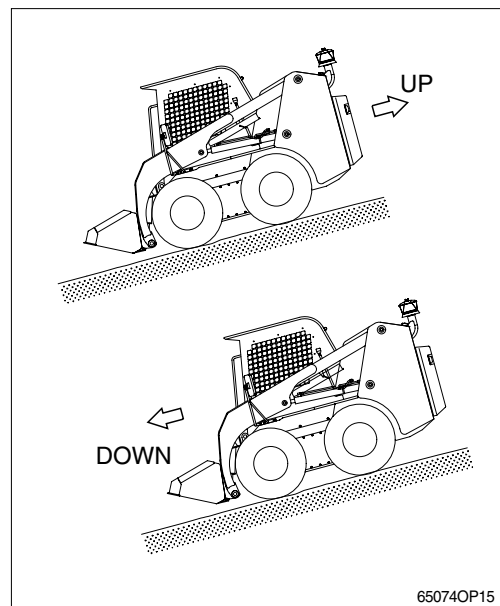

10. BUCKET INSTALLATION

- 1) The bucket should be on firm level ground.
- 2) Raise both hand levers on the attachment holder until the locking pins are retracted into the attachment holder. (Unlock position)
- 3) Operate the machine so that the attachment holder(Quick coupler) hooks on to the bucket.
- 4) Slowly tilt the attachment holder back against the boom.
- 5) Release the seat belt and raise the seat bar.
- 6) Lower engine throttle speed to idle and carefully exit the loader using the hand holds.
- 7) Fully lower both hand levers down(Lock position). This pushes the locking pins down through the slots at the base of the bucket.
- 8) Check by pushing the bucket to the ground that it is connected correctly.

▲ To prevent personal injury or death, the controls must always be locked in neutral during entry or exit from the machine.

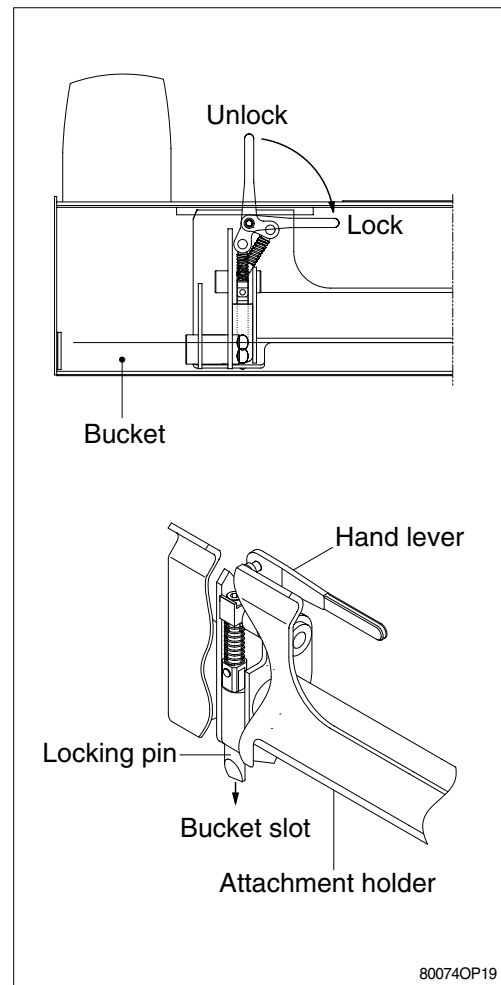

11. BUCKET REMOVAL

- 1) If removing an attachment other than a bucket, follow the specific removal instructions for that attachment.
- 2) The bucket should rest on firm level ground.
- 3) Fully raise both hand levers until the locking pins are retracted into the attachment holder. (Unlock position)
- 4) Carefully enter the loader using the hand holds, buckle the seat belt, increase engine throttle, tilt the attachment holder forward, and drive backward until the top of the attachment holder slips out from under the top lip of the bucket.

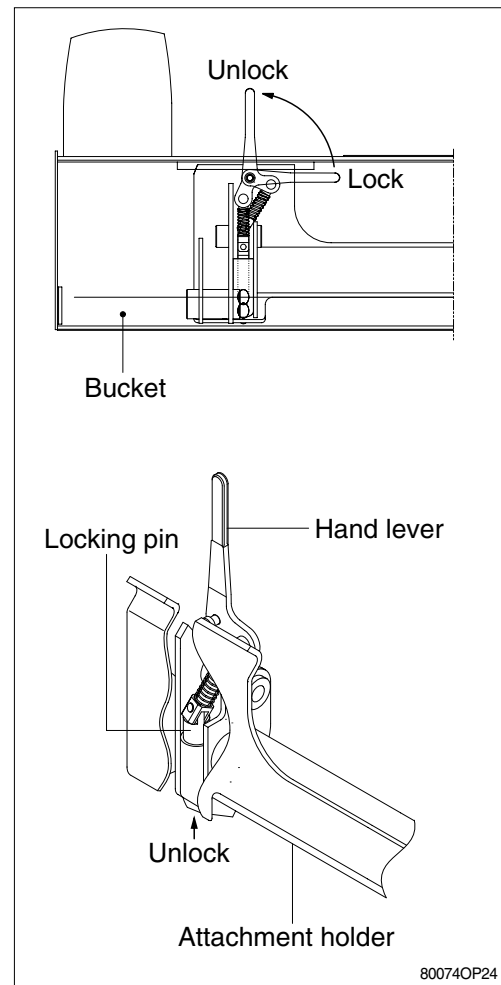

12. ENGAGING AND DISENGAGING THE BOOM LOCK DEVICE

1) ENGAGING THE BOOM LOCK DEVICE

Maintenance and service work can be done with the boom lowered. If the boom are raised, use the following procedure:

- (1) Put jackstands under the rear corners of the loader.

Disconnect the spring from the locking pin, hold onto the lock device and remove the locking pin.

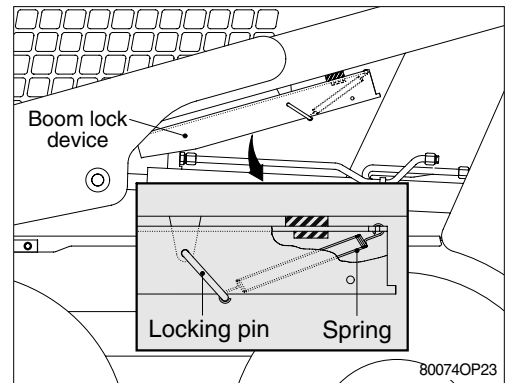

- (2) Lower the boom lock device on top of the boom cylinder.

Hook the free end of the spring to the boom lock device so there will be no interference with the lock device engagement.

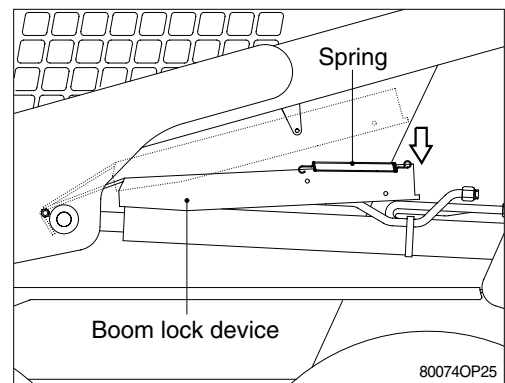

- (3) With the operator in the seat, seat belt fastened and seat bar lowered, start the engine.

Raise the boom, until the boom lock device drops onto the boom cylinder rod.

Lower the boom slowly until the lock device is held between the boom and the boom cylinder. Stop the engine. Release the seat belt and raise the seat bar.

Install locking pin into the rear of the boom lock device below the cylinder rod.

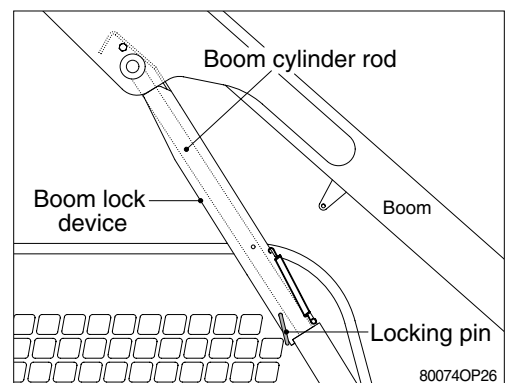

2) DISENGAGING THE BOOM LOCK DEVICE

- (1) Remove the locking pin from the boom lock device.
Connect the spring from the boom lock device to the bracket below the boom.

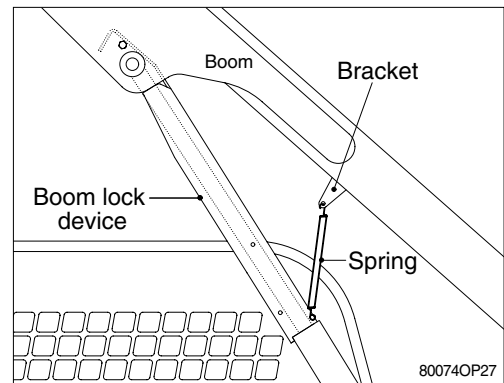

- (2) With the operator in the seat, seat belt fastened and seat bar lowered, start the engine. Raise the boom a small amount and the spring will boom the lock device off the boom cylinder rod lower the boom. Stop the engine. Release the seat belt and raise the seat bar. Disconnect the spring from the bracket. Raise the lock device into storage position and insert pin through boom lock device and bracket. Connect spring to pin.

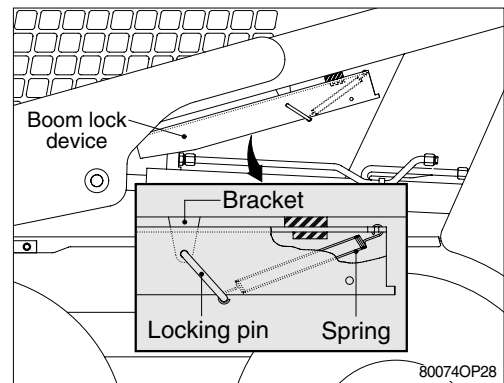

13. RAISING AND LOWERING THE OPERATOR CANOPY

1) RAISING THE OPERATOR CANOPY

- (1) Stop the loader on a level surface. Lower the boom.
- (2) Loosen the nut(Both sides) at the front corner of the operator canopy.
- (3) Remove the washer and nut(Both sides).
- (4) Lift on the grab handle and bottom of the operator canopy slowly.

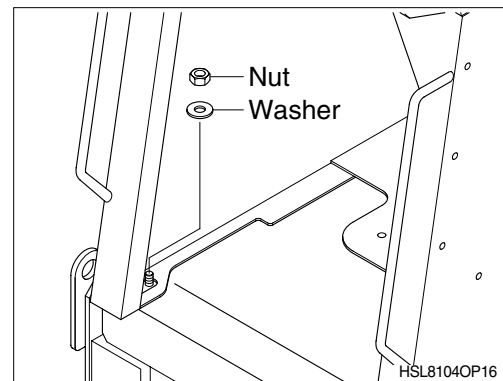

- (5) Loosen the locking screw and move lock pin into the rear frame.

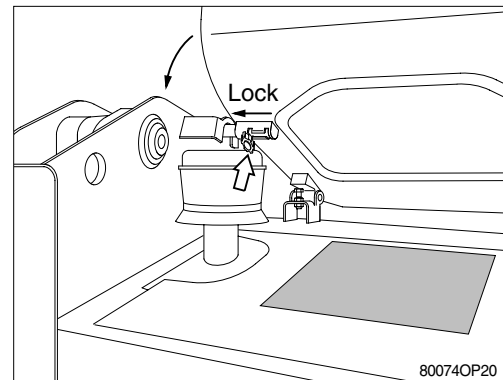

2) LOWERING THE OPERATOR CANOPY

- (1) Loosen the locking screw and unlock lock pin from the rear frame.

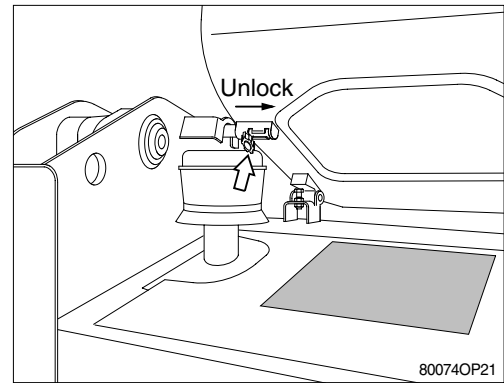

- (2) Push the lock pin of the gas spring.
Pull down on the bottom of the operator canopy.

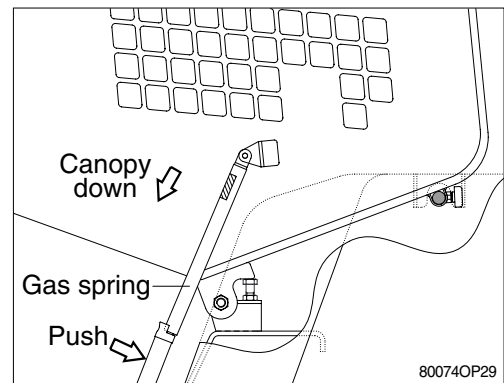

- (3) Install the washer and nut(Both side).

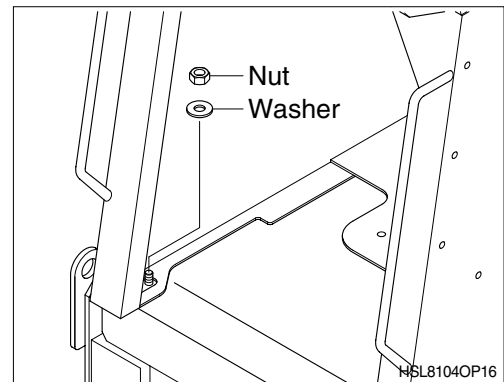

14. MATERIALS HANDLING OPERATIONS

This machine is extremely effective in performing powerful hauling and loading. For safe, economical handling, the operator must have a thorough knowledge of operations and a good grasp of the construction and performance features of the machine. Then, on the job, he must choose the operating approach and match the actual conditions with outstanding driving and operation techniques.

Never put more demands on the machine than performance or capacities allow. This not only increases repair costs, it jeopardizes the safety of the operator and nearby workers as well.

Any job must be undertaken with an eye on driver safety and others in the vicinity of the machine. Basic operation methods are explained here.

1) BUCKET SCOOP OPERATIONS

Move the machine forward slowly with the bucket held parallel to the ground or tilted slightly down, then raise the bucket by moving the control lever.

When the bucket is sufficiently full tilt it back by moving the control lever.

⚠ Always scoop with the bucket moving parallel to the material to be scooped. Do not allow the bucket to tilt as this will put excessive strain on the boom, bucket, and other parts and damage them.

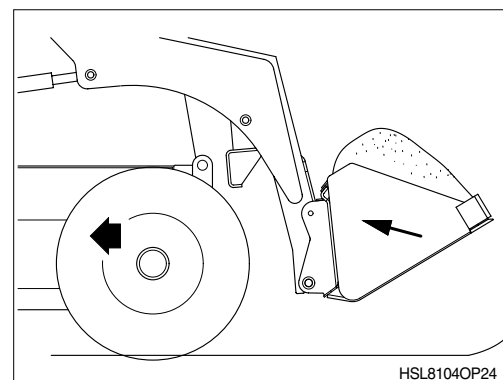
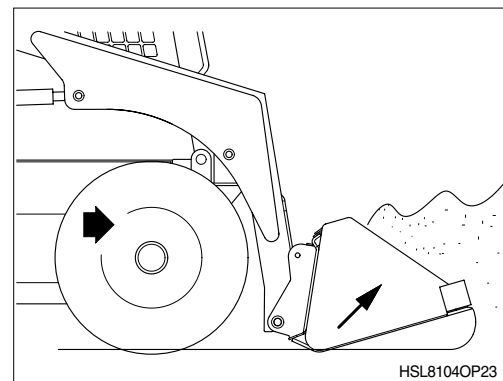
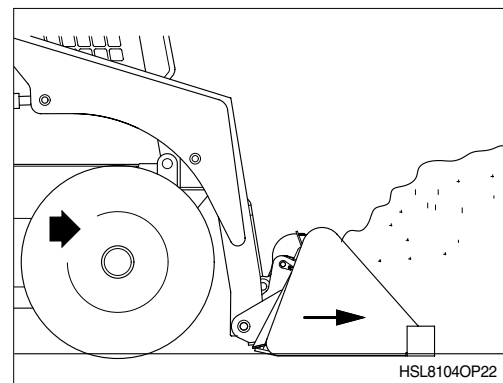
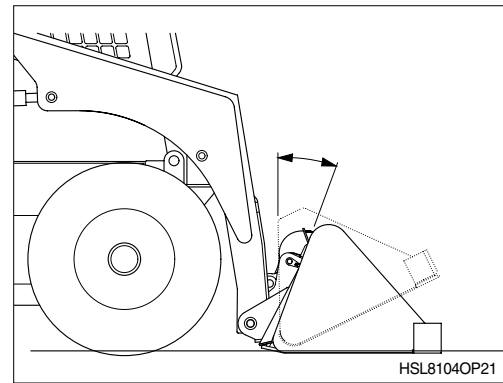

2) BUCKET SCRAPE OPERATIONS

Advance with the bucket tilted down at the angle which ground hardness permits. Move forward slowly, letting the bucket scrape until it fill. Then, tilt back the bucket and haul away.

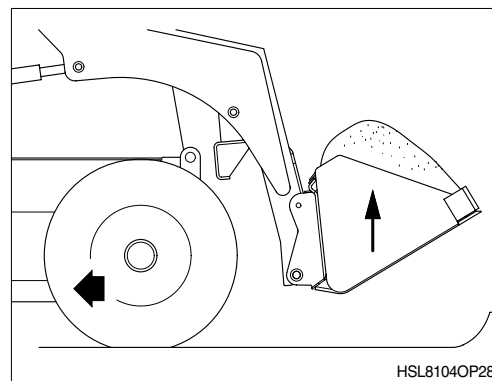
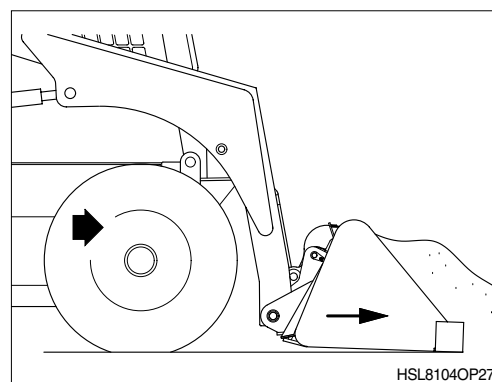
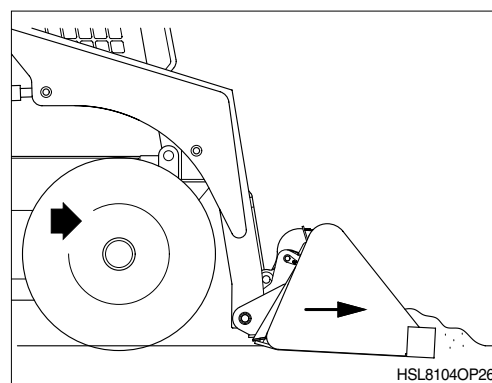
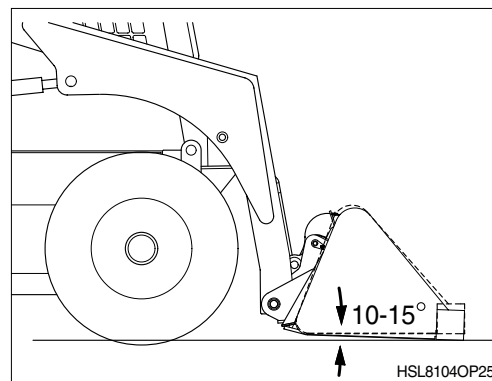

3) GRADING AND LEVELING

The bucket is tilted forward and raised slightly off the ground to perform grading and leveling jobs.

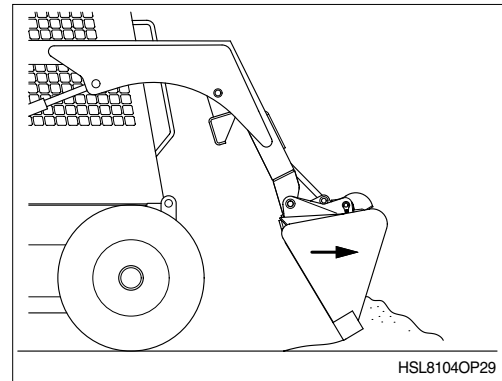

4) FILLING

Hole filling and similar operations are possible.

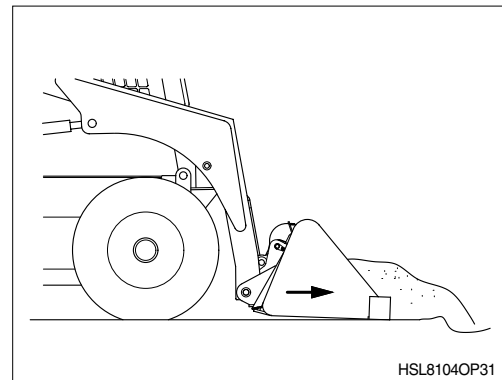

5) BACKFILLING

Backfilling can be done by tilting the bucket forward and backing up with the edge slightly off the ground.

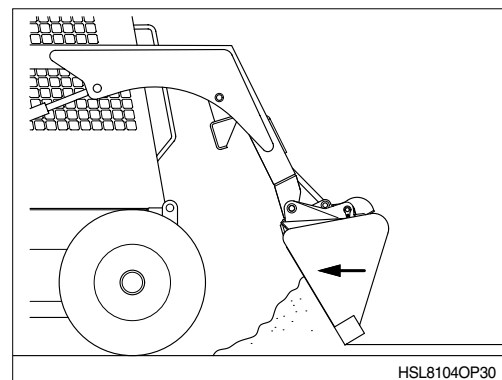

6) FLOAT POSITION

It is sometimes easier to work the boom in the float position.

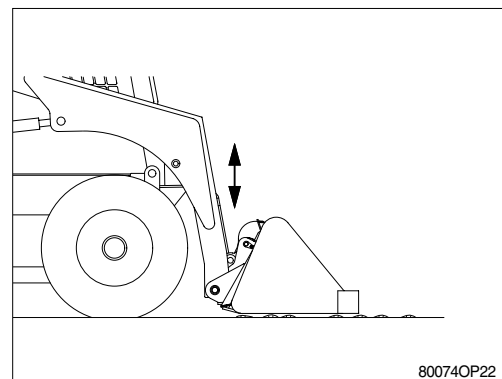

7) LOADING OPERATIONS

Stop the machine near the truck and raise the bucket high enough to clear the upper edge of the truck.

Approach slowly, tilt bucket forward and stop machine.

Tilt the bucket forward to dump a bucketful in the truck.

The bucket may be used to level off the truck load.

To dislodge sticky material, shake the bucket up and down by gently moving the RH control lever.

- ※ **Do not shake the bucket when unnecessary as this will put strain on the bucket stopper.**

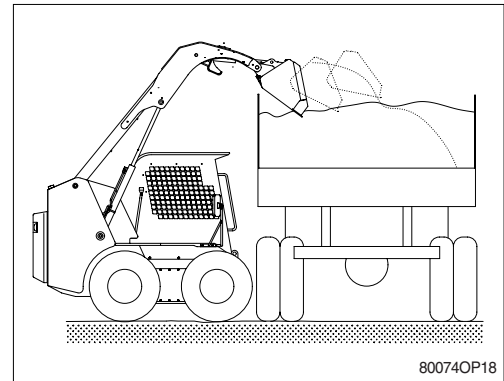

15. OPERATION IN THE SPECIAL WORK SITES

1) OPERATION THE MACHINE A COLD WEATHER

- (1) Use proper engine oil and fuel for the weather.
- (2) Fill the required amount of antifreeze in the coolant.
- (3) Refer to the starting engine in cold weather.
Start the engine and extend the warming-up operation.
- (4) Be sure to open the heater cock when using the heater.
- (5) Always keep the battery completely charged.
※ **Discharged batteries will freeze more easily than fully charged.**
- (6) Clean the machine and park on the wood plates.

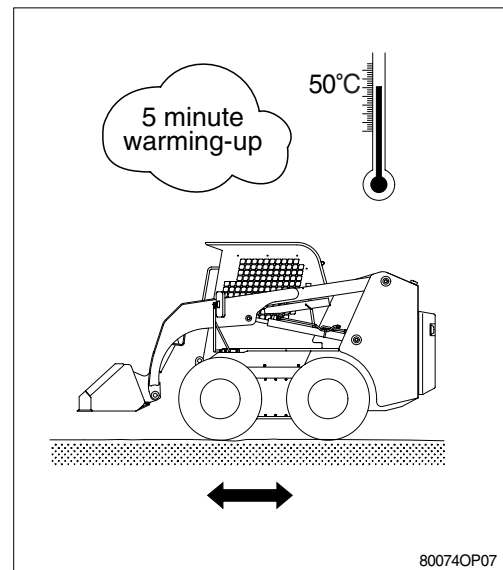

2) OPERATION IN SANDY OR DUSTY WORK SITES

- (1) Inspect air cleaner element frequently. Clean or replace element more frequently.
- (2) Inspect radiator frequently, and keep cooling fins clean.
- (3) Prevent sand or dust from getting into fuel tank and hydraulic tank during refilling.
- (4) Prevent sand or dust from penetrating into hydraulic circuit by tightly closing breather cap of hydraulic oil tank. Replace hydraulic oil filter frequently.
- (5) Keep all lubricated part, such as pins and bushings, clean at all times.

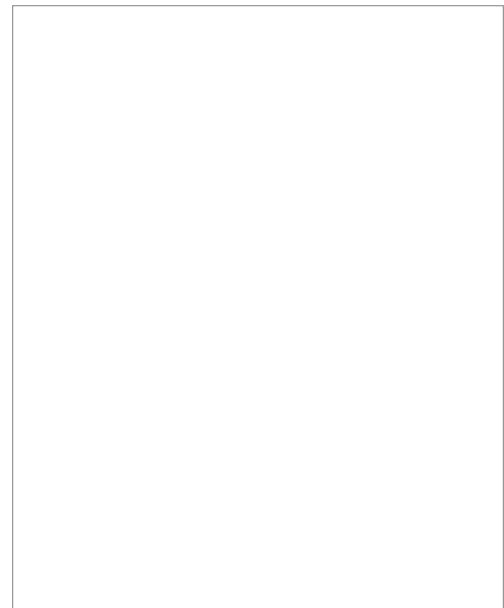

2) CAUTIONS AFTER COMPLETION OF WORK

To prevent mud, water, or the attachment from freezing and making it impossible for the machine to move on the following morning, always observe the following precautions.

- (1) Mud and water on the machine body should be completely removed.
This is to prevent damage to the seal caused by mud or dirt getting inside the seal with frozen drops of water.
- (2) Park the machine on concrete or hard ground. If this is impossible, park the machine on wooden boards.
- (3) Drain water collected in fuel system because such water may be frozen at night.
- (4) As battery capacity drops at low ambient temperature, cover the battery or remove it from the machine to be kept warm at night.

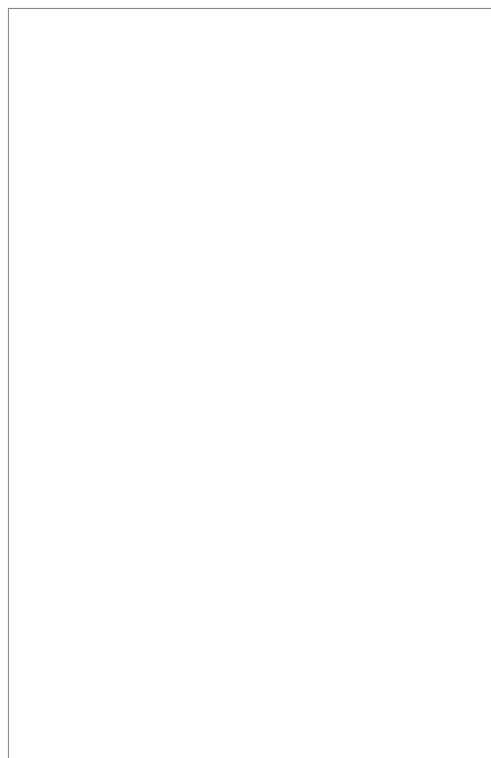

16. LONG TERM STORAGE

1) BEFORE STORAGE WITHOUT OPERATION

- (1) Carefully wash and clean each part.
- (2) Perform lubrication and oil change for all necessary parts without omission.
- (3) Apply grease thinly on the exposed portions of hydraulic cylinder piston rods.
- (4) If a long life coolant is not used, thoroughly drain the coolant from the cylinder block and radiator.
- (5) Remove the battery after full charging, and store it in a cool, dry place.
- (6) Pull the throttle lever fully backward and keep the start switch at the OFF position.
- (7) Store the machine indoors. If outdoor storage is unavoidable, place the machine on blocks and cover with waterproof canvas.

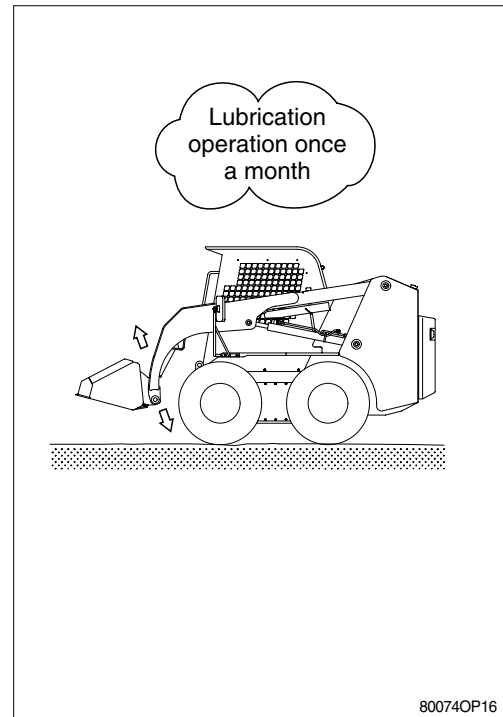

2) DURING STORAGE

During storage, run the engine, move the machine back and forth and operate each control lever at least once a month for lubrication of each part.

3) AFTER LONG STORAGE

- (1) Remove the drain plug from the fuel tank, oil pan, etc., to drain water accumulated in each part.
- (2) After starting the engine, carry out sufficient warm up and inspect each part carefully.

