

5. TRANSPORTATION

1. ROAD TRAVELING

If it is necessary to travel on a road, observe the followings.

- 1) Comply with regulations regarding this machine for the sake of safety.
- 2) Perform daily inspection before starting the machine.
- 3) Check the air pressure of tires and traveling speed limitations.
 - Air pressure : 3.25kg/cm²(46psi)
 - Maximum speed : 11.8km/hr(7.4mph)
- 4) When traveling for a long distance, stop every hour or every 12km(7.4mile) to allow tires and other components to cool down and check any abnormality.
- 5) Drive with the bucket empty.
- 6) Travel at a mid-range speed and be careful to drive with in the limited speed when driving on a public road.

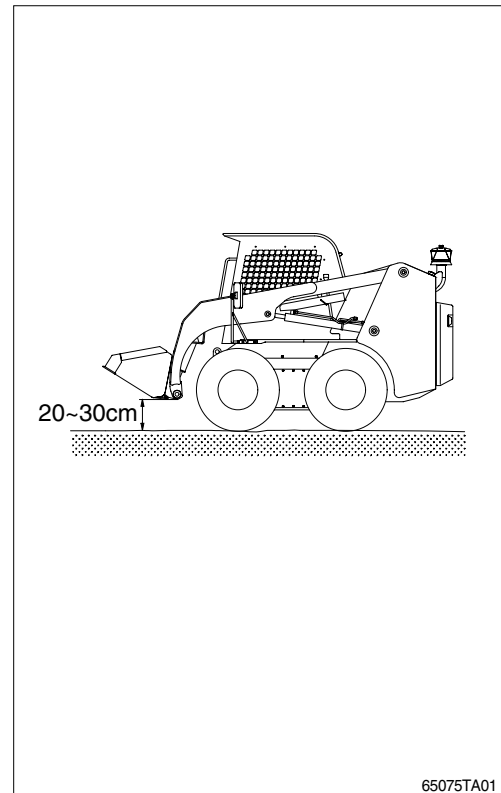

2. TRANSPORTATION

Use of a special platform is desirable for loading and unloading of the machine for transportation.

When gangplanks have to be used, try safe operation, paying attention to the following points.

1) Stop the engine, apply the parking brake and block tires of the truck.

2) Set left and right gangplanks so that the truck and the machine are centered.

Use 450mm or wider gangplanks which can sufficiently endure the machine can sufficiently endure the machine weight.

Fasten them firmly to the truck bed by using proper fittings. Install them without level difference between the left and right, and limit the board inclination within 15°.

3) Adjust the machine direction before getting on the gangplanks, and load the machine slowly by backward traveling.

▲ Never change the direction on the gang planks.

Always assign a guide and carefully operate for

▲ Ascending and descending on the gangplanks.

4) Apply the parking brake, fix the machine body to the truck bed with wire ropes and use wheel blocks to prevent machine movement during transportation. Bring the bucket into close contact with the truck bed.

Fix the body to the truck bed as described below.

• Front side

Pass a wire rope through holes on both sides of the front plate, and fix the body firmly to the truck bed.

• Rear side

Pass a wire rope through the left and right rear hooks for fixing to the bed.

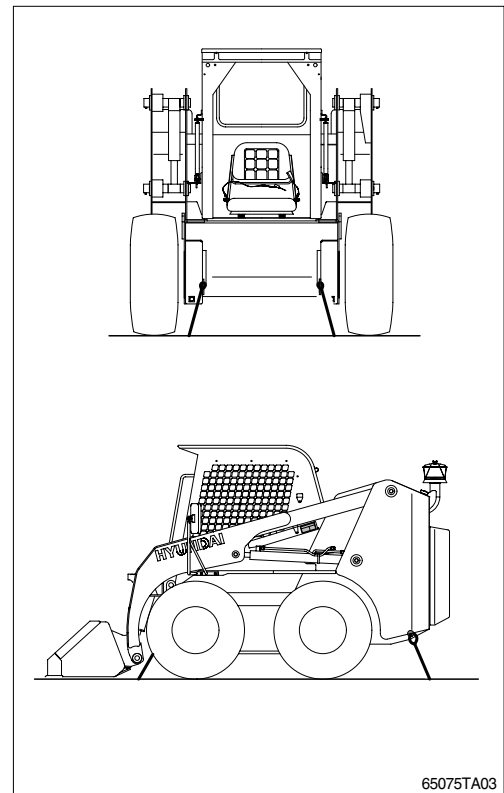
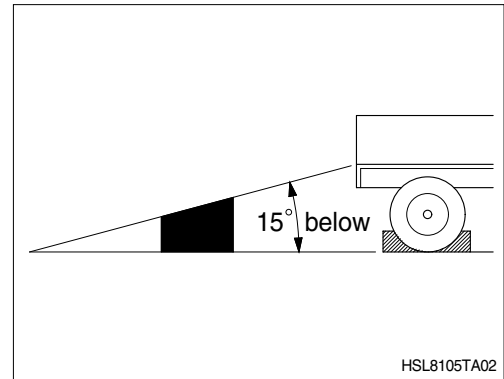

3. LOADING AND UNLOADING BY CRANE

- 1) Check the weight, length, width and height of the machine referring to **chapter 2, specification** when you are going to hoist the machine.
- 2) Use long wire rope and stay to keep the distance with the machine as it should avoid to touch with the machine.
- 3) Put a rubber plate contact with wire rope and machine to prevent damage.
- 4) Place crane on the proper place.
- 5) Install the wire rope and stay like th illustration.

- ⚠ **Make sure wire rope is proper size.**
- ⚠ **The wrong hoisting method or installation of wire rope can cause damage to the machine.**
- ⚠ **Do not load abruptly.**
- ⚠ **Keep area clear of personnel.**

