

3. CONTROL DEVICES

1. LOCATIONS

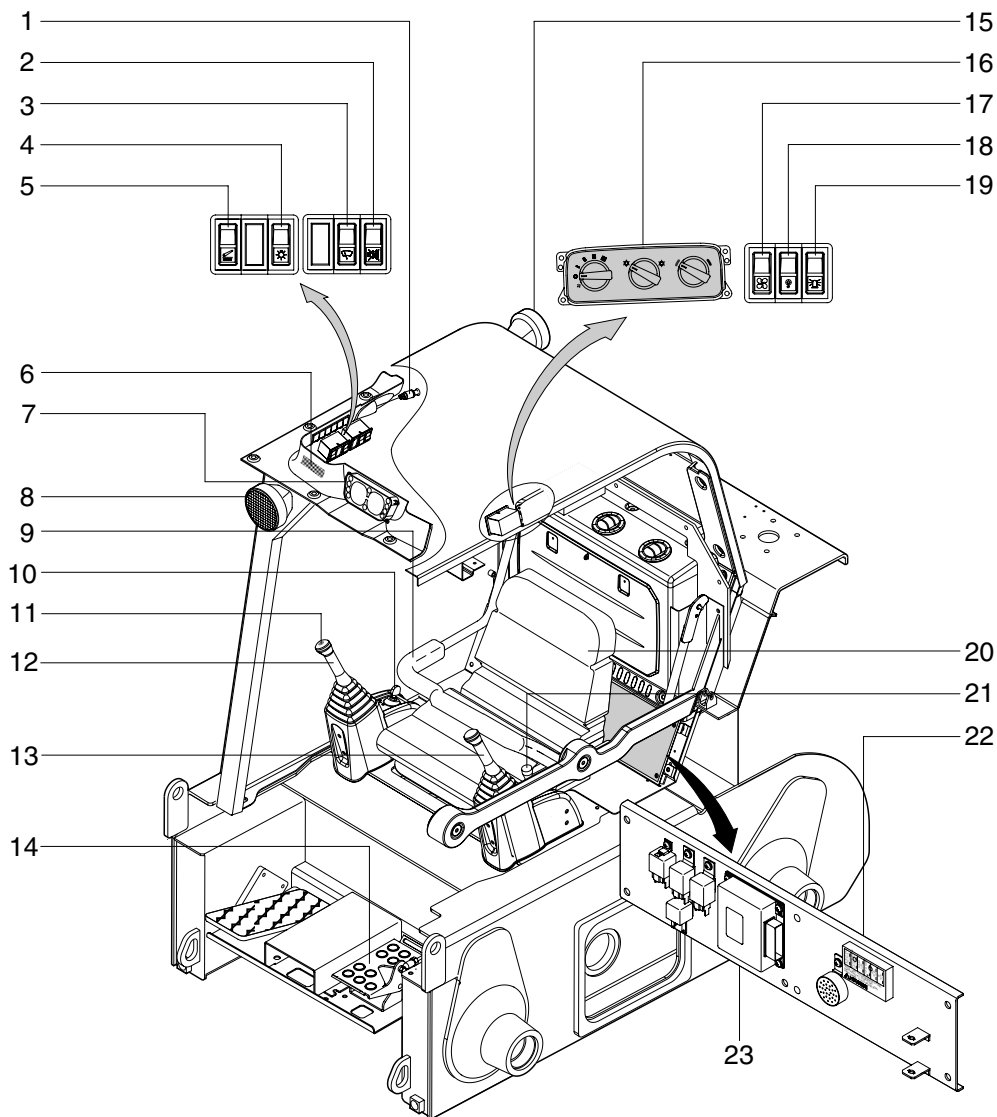

65073CD01

- | | |
|------------------------------------|---|
| 1 Cigar lighter | 13 Steering/boom control lever(LH) |
| 2 Buzzer stop switch | 14 Auxiliary hydraulic pedal(Optional) |
| 3 Wiper switch(Optional) | 15 Rear work light(Optional) |
| 4 Main light switch | 16 Aircon & heater controller(Cab type, option) |
| 5 Reset switch | 17 Heater switch(Cab type, option) |
| 6 Room lamp | 18 Overload switch(Optional) |
| 7 Warning indicator panel | 19 Beacon switch(Optional) |
| 8 Front work light(LH, RH) | 20 Operator's seat |
| 9 Seat bar | 21 Engine throttle lever |
| 10 Start switch | 22 Fuse box |
| 11 Horn switch | 23 Control unit |
| 12 Steering/Boom control lever(RH) | |

2. WARNING INDICATOR PANEL

The indicator panel consists of gauges and monitors as shown below, to warn the operator in case of abnormal machine operation or conditions for the appropriate operation and inspection.

- Gauges : Indicate operating status of the machine.
- Warning lamp : Indicate abnormality of the machine.
- Pilot lamp : Indicate operating status of the machine.

※ The monitor installed on this machine does not entirely guarantee the condition of the machine. Daily inspection should be performed according to chapter 6, MAINTENANCE.

※ When the monitor provides a warning immediately check the problem, and perform the required action.

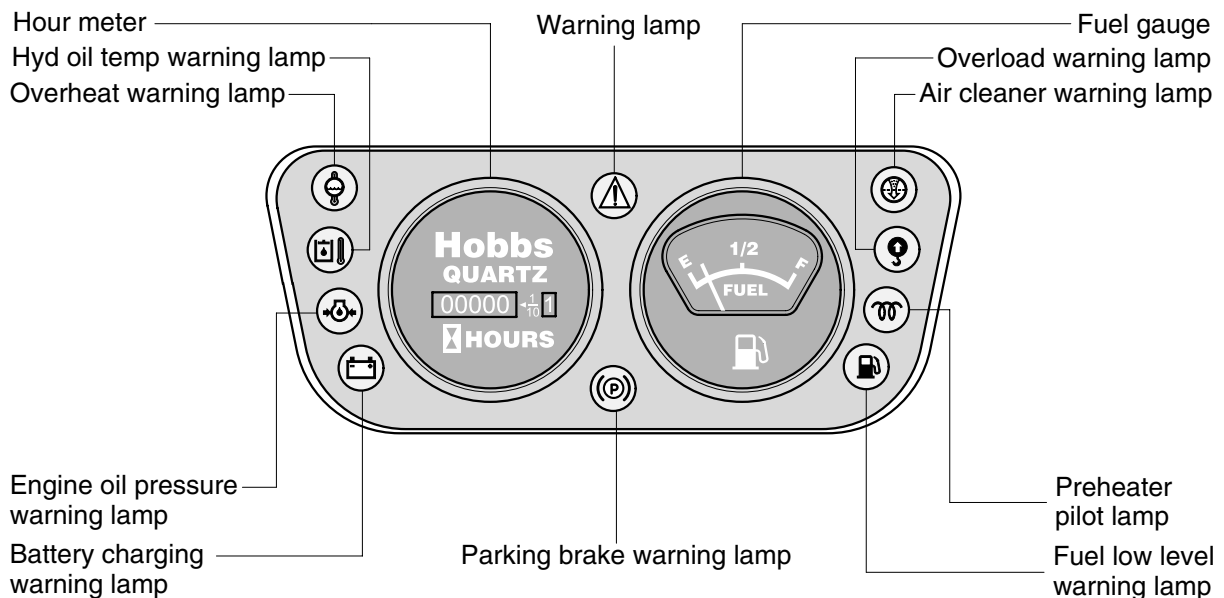

80073CD02

1) FUEL GAUGE

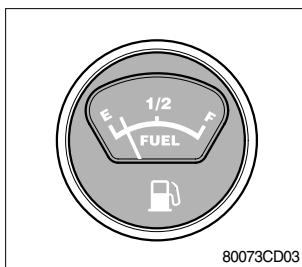

- (1) Indicates the quantity of fuel in the fuel tank.
- (2) It operates when the start switch is ON. **F** indicates full and **E** indicates empty.
- (3) To avoid getting air into the fuel system, refuel before the indicator reaches **E**.

2) HOUR METER

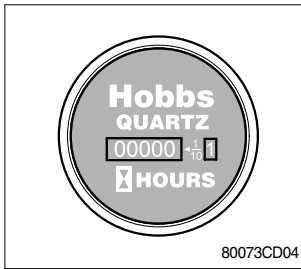

(1) Records engine operating hours and has a total read out of 9999.9 hours.

(2) It only operates when the engine is running.

3) WARNING LAMP

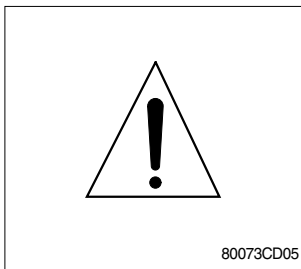

(1) When you raise the seat bar, this warning lamp will flash.

(2) When you lower the seat bar, this warning lamp is turned OFF.

4) OVERHEAT WARNING LAMP

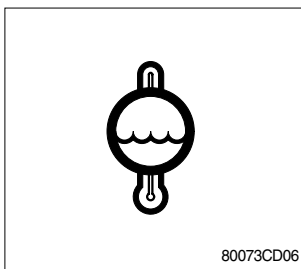

(1) This lamp is turned ON when the temperature of cooling water is over the 104°C(219°F).

(2) Check the cooling system when the lamp is ON.

5) HYD OIL TEMPERATURE WARNING LAMP

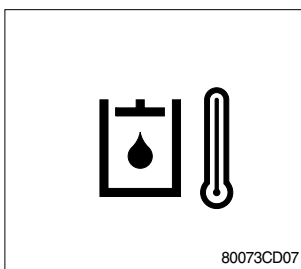

(1) This warning lamp operates and the buzzer sounds when the temperature of hydraulic oil is over 105°C(221°F).

(2) Check the hydraulic oil level when the lamp is turned ON.

(3) Check for debris between oil cooler and radiator.

6) ENGINE OIL PRESSURE WARNING LAMP

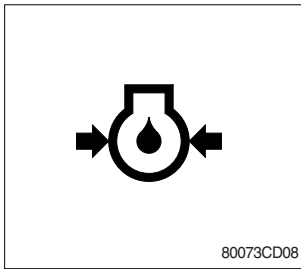

- (1) Light to indicate low engine oil pressure and the buzzer sounds.
 - (2) The lamp comes ON when the start switch is turned ON and should go off when the engine starts.
- ※ **If the lamp comes ON during engine operation, this indicates a malfunction in the lubrications system or an oil shortage, stop operation immediately and have the machine inspected or repaired.**

7) BATTERY CHARGING WARNING LAMP

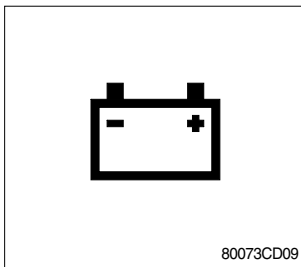

- (1) This lamp is ON when key ON, it is turned OFF after starting the engine.
- (2) Check the battery charging circuit when this lamp comes ON, during engine operation.

8) PARKING BRAKE WARNING LAMP

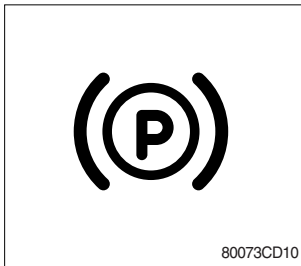

- (1) When the parking brake is actuated, the lamp lights ON.
- ※ **Check the lamp is OFF before driving.**

9) AIR CLEANER WARNING LAMP

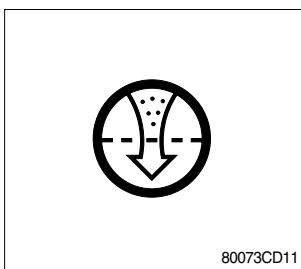

- (1) This lamp operates by the vacuum caused inside when the filter of air cleaner is clogged and the buzzer sounds.
- (2) Check the filter and clean or replace it when the lamp is ON.

10) OVERLOAD WARNING LAMP (Option)

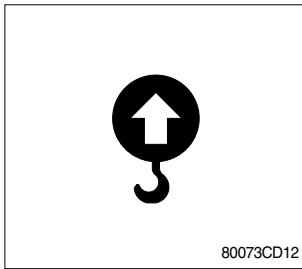

- (1) When the machine is overload, the overload warning lamp operates during the overload switch ON.

11) PREHEATER PILOT LAMP

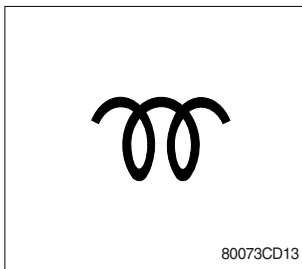

- (1) This lamp lights ON when start switch is turned clockwise to the ON position. Light will turn off after approximately 5~20 seconds, depending on engine coolant temperature, indicating that preheating is completed.
- (2) When the lamp goes out the operator should start cranking the engine.

※ Refer to page 4-4.

12) FUEL LOW LEVEL WARNING LAMP

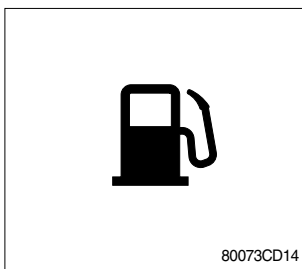

- (1) Fill the fuel immediately when the lamp is turned ON.

3. OPERATING LEVERS AND SWITCHES

1) STARTING SWITCH

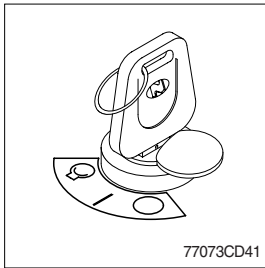

(1) There are three positions, OFF, ON and START.

- ○ (OFF) : None of electrical circuits activate.
- | (ON) : All the systems of machine operate.
- Ⓚ (START) : Use when starting the engine.

Release key immediately after starting.

※ **Key must be in the ON position with engine running maintain electrical and hydraulic function and prevent serious machine damage.**

2) BUZZER STOP SWITCH

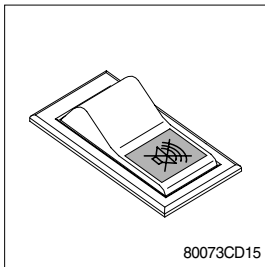

(1) The warning lamp on the indicator panel lights ON and the buzzer sounds when the machine has a problem.

In this case, if the switch is pressed, the buzzer will be stopped. Be sure to check machine for problems.

(2) Wait until the lamp is turned OFF, if the warning lamp lights ON after the buzzer stopped.

If not, stop engine and check the system which the lamp is ON.

3) WIPER SWITCH(Cab type, option)

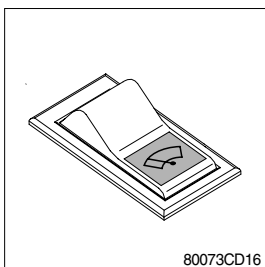

(1) The switch is used to operate the wiper and washer by two step.

- First step : The front wiper operates.
- Second step : The washer liquid is sprayed and the front wiper is operated only while pressing. If release the switch, return to the first step position.

(2) The below indicator lamp is turned ON when operating this switch.

4) MAIN LIGHT SWITCH

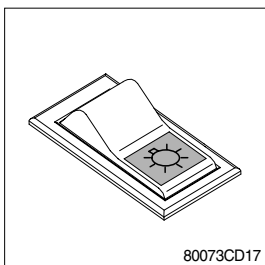

(1) The switch is used to operate the front and rear work light.

- First step : Front work lights, cigar light lamp and fuel gauge lamp comes ON.
- Second step : Rear work light(Option) comes ON.

(2) The below indicator lamp is turned ON when operating this switch.

5) RESET SWITCH

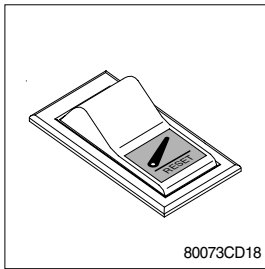

- (1) With seat belt secured, seat bar down and engine running, the operator must momentarily press the reset button before the loader boom raise/lower hydraulic system can be functional.
- (2) The loader boom raise/lower hydraulic system will remain active until the seat bar is raised or the start switch is turned OFF.

6) HEATER SWITCH(Cab type, option)

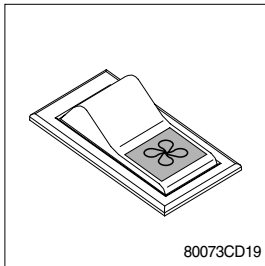

- (1) This switch is used to operate the heater.
- (2) The below indicator lamp is turned ON when operating this switch.

7) OVERLOAD SWITCH(Option)

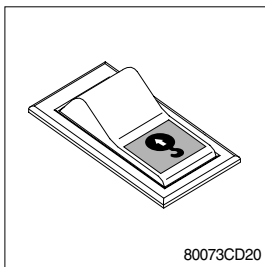

- (1) When this switch is turned ON, buzzer makes sound and overload warning lamp comes ON in case that the machine is overload.
- (2) When turn OFF buzzer stops and warning lamp goes out.

8) BEACON SWITCH(Option)

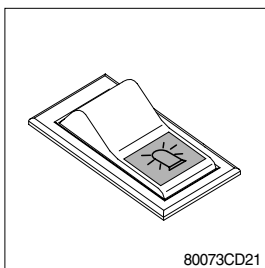

- (1) This switch turns ON the rotary light on the cab roof.
- (2) The below indicator lamp is turned ON when operating this switch.

9) ENGINE THROTTLE LEVER

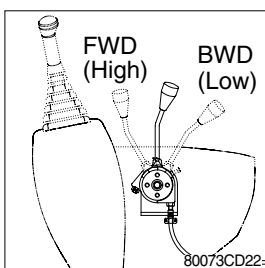

- (1) The engine throttle lever is located the left side of the operator's seat.
 - (2) Engine speed is controlled by moving throttle lever forward to increase the engine speed and backward to decrease the engine speed.
- ▲ Set the engine throttle lever to high position after engine is stopped when tilting the cab.**

10) LH CONTROL LEVER

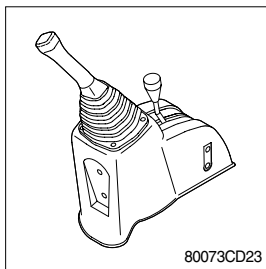

- (1) This control lever is used to control the steering and the boom.
- (2) Refer to operation of working device at page 4-8 for detail.

11) RH CONTROL LEVER

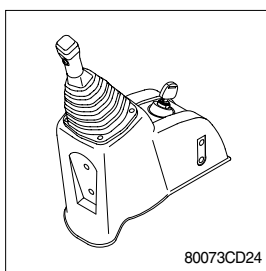

- (1) This control lever is used to control the steering and the bucket.
- (2) Refer to operation of working device at page 4-8 for detail.

12) HORN SWITCH

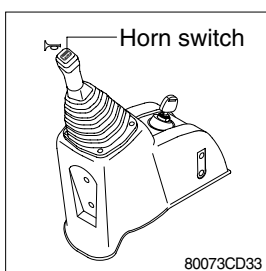

- (1) If you press the switch on the top of the RH control lever, the horn will sound.

13) AUXILIARY HYDRAULIC PEDAL (Option)

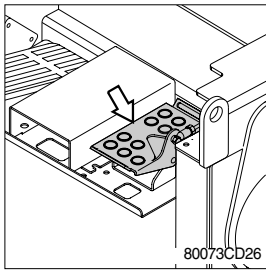

(1) This foot pedal controls the auxiliary attachment.

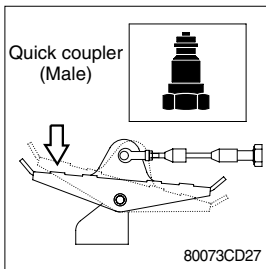

(1) Press the front of the foot pedal to provide hydraulic fluid pressure through the male coupling to an auxiliary attachment.

(2) Hydraulic oil will return to tank through the female coupling.

(3) When you release the pedal, it returns to neutral position automatically.

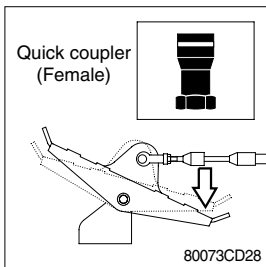

(4) Press the rear of the foot pedal to provide hydraulic fluid pressure through the female coupling to an auxiliary attachment.

(5) Hydraulic oil will return to tank through the male coupling.

4. AIR CONDITIONER AND HEATER(CAB TYPE)

Air conditioner and heater are equipped for pleasant operation against outside temperature.

- Location of air outlet

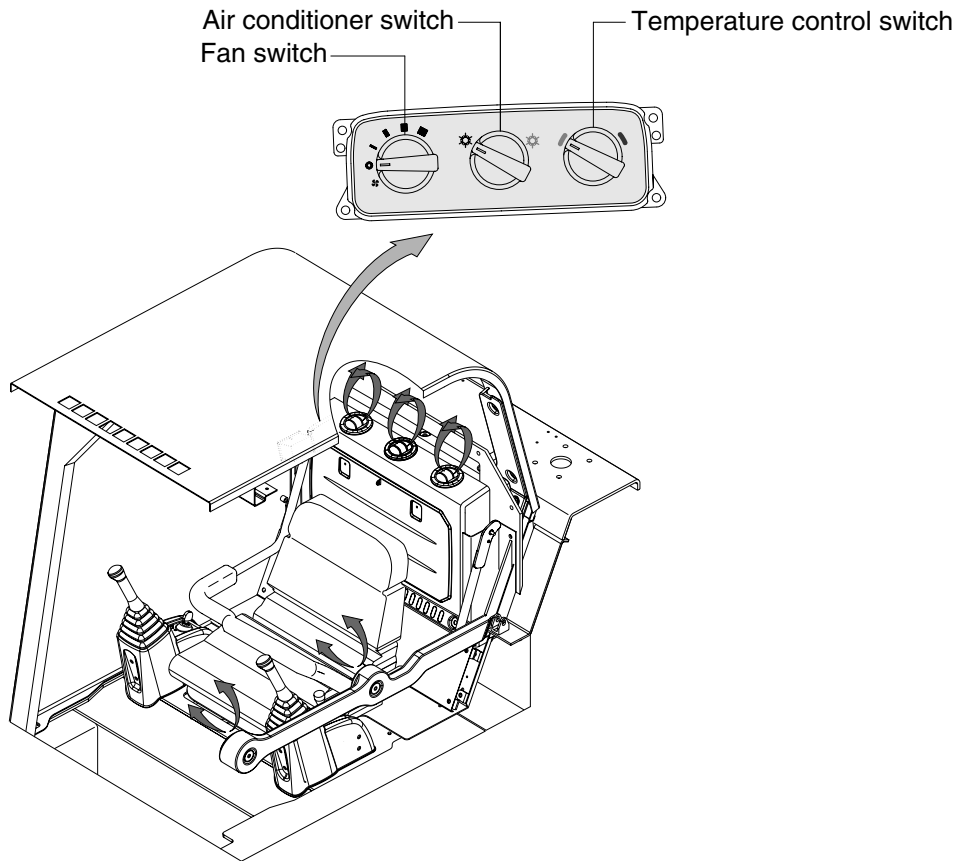



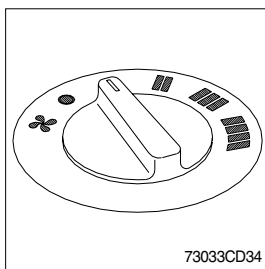

80073CD29

1) FAN SWITCH





It is possible to control the fan to four steps.

-  : Low
-  : Medium-Low
-  : Medium-High
-  : High

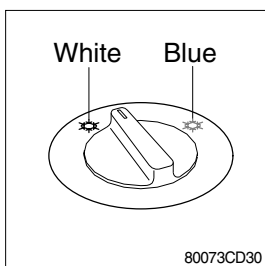
2) AIR CONDITIONER SWITCH



This switch use to operates the air conditioner.

-  (White) : Air conditioner ON
-  (Blue) : Air conditioner OFF

3) TEMPERATURE CONTROL SWITCH

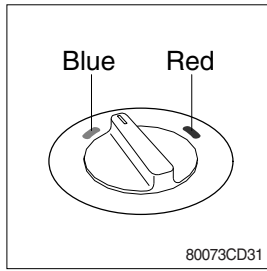

(1) Cooling(Air conditioner switch : ON)

- ① Turned ON the air conditioner switch on the controller.
- ② Turn the control switch into blue range to decrease output air temperature.

(2) Heating(Air conditioner switch : OFF)

- ① Turned OFF the air conditioner switch on the controller.
- ② Turn the control switch into red range to increase temperature.

4) OUTLET CONTROL LOUVER

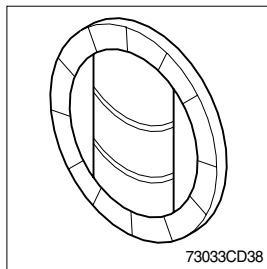

(1) The direction of air can be controlled.

(2) It can be closed or opened.

5. OTHERS

1) CIGAR LIGHTER

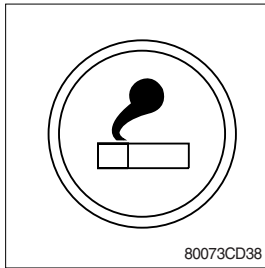

- (1) This can be used when the engine starting switch is ON.
- (2) The lighter can be used when it springs out in a short while after being pressed down.
- (3) The indicator lamp is turned ON when the main light switch is pressed by first step.

※ **Service socket**

Use cigar lighter socket when you need emergency power.

Do not use the lighter exceeding 12V, 120W

2) SEAT BAR

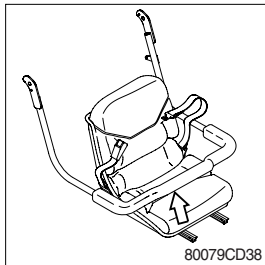

- (1) With your seat belt fastened, the seat bar raised and the engine running ; Loader does not move when you move either control lever forward or backward.
- (2) Parking brake must engage(ON) when you raise the bar and disengage(OFF) when you lower the bar.

※ **Especially when leaving the driver's seat, be absolutely careful for the following points:**

- Always return the control lever to its neutral position if it remains in the floating stage.
- Make certain there are no articles on the operator's seat.
- Disconnect the seat belt.
- Make sure the start switch is turned OFF.
- Raise the seat bar.
- Carefully exit the loader using the hand holds.

3) SEAT BELT

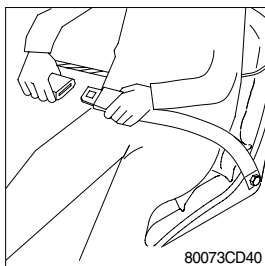

- (1) When buckling the belt, make sure that it is not twisted and insert the plate on the right side into the buckle on the left until it clicks to the position.
- (2) When the belt length is short, lengthen the belt by adjusting it as illustrated.
- (3) Pull the belt to eliminate any slack, as illustrated.

▲ **Always buckle the seat belt when operating the machine.**

▲ **Always make sure the seat belt is disconnected when leaving the operator's seat.**

4) OPERATORS SEAT

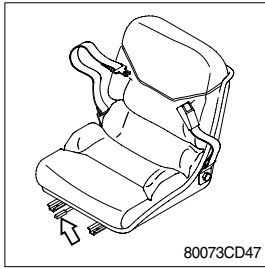

- (1) Forward and backward adjustment is possible using the adjust lever.
- (2) The seat can be moved forward and backward over 150mm(5.9in).
- (3) Adjust to a comfortable operating position.

5) FUSE BOX

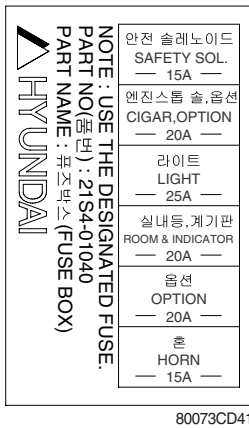

- (1) The fuses protect the electrical parts and wiring from burning out.
 - (2) The fuse box cover indicates the capacity of each fuse and circuit it protects.
- ※ **Replace a fuse with another of the same capacity.**
- ▲ **Before replacing a fuse, be sure to turn OFF the starting switch.**

6) CONTROL UNIT

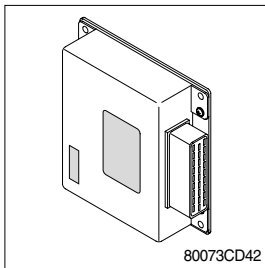

- (1) It consists of electronic parts and controls all lamps and buzzers on indicator panel in accordance with signals transmitted from the switches, the engine and the hydraulic pressure sensors.

7) MASTER SWITCH

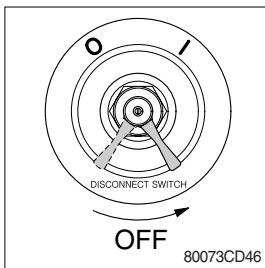

- (1) This switch is used to shut off the entire electrical system.
 - (2) I : The battery remains connected to the electrical system.
 O : The battery is disconnected to the electrical system.
- ※ **Never turn the master switch to O(OFF) with the engine running. Engine and electrical system damage could result.**

8) EMERGENCY EXIT

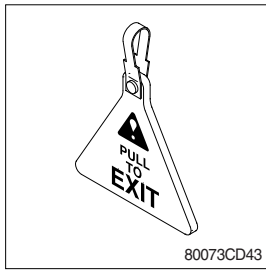

(1) The front opening on the operator cab and rear window provide exits.

(2) To exit through the rear window, use the following procedure.

- ① Pull on the tag at the rear window to remove the rubber cord.
- ② Push the rear window out of the rear of the operation cab.
- ③ Exit through the rear of the cab.

9) HOLD REAR DOOR IN OPENING

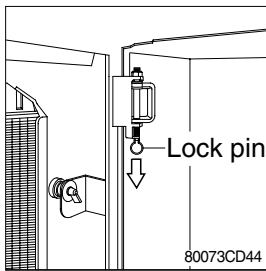

(1) Open the rear door fully (about 95°), then the rear door is held automatically by lock pin and pull down the lock pin to close the rear door.