

## 2. SPECIFICATIONS

### 1. MAJOR COMPONENT

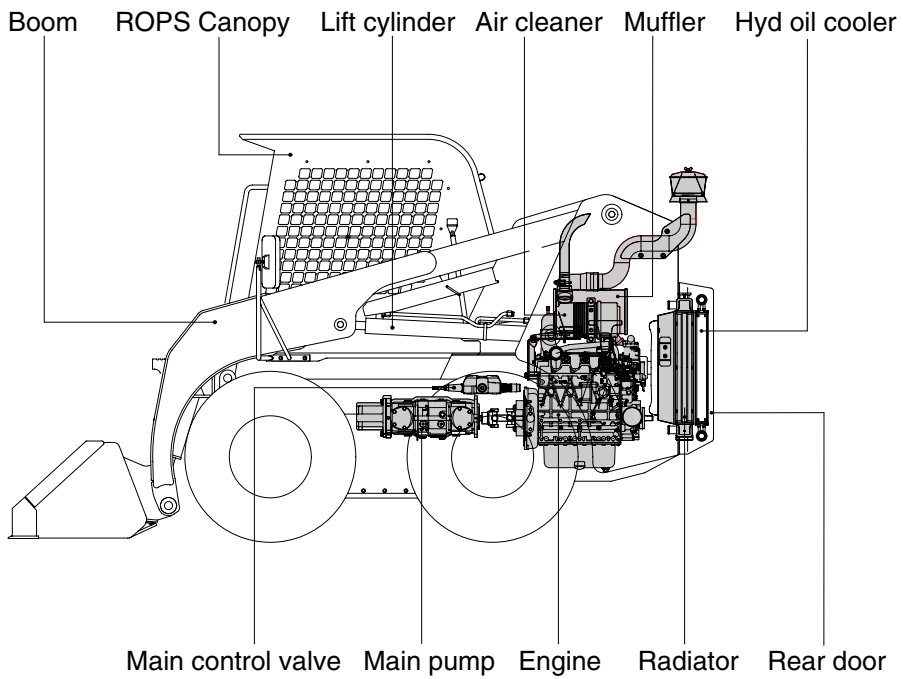
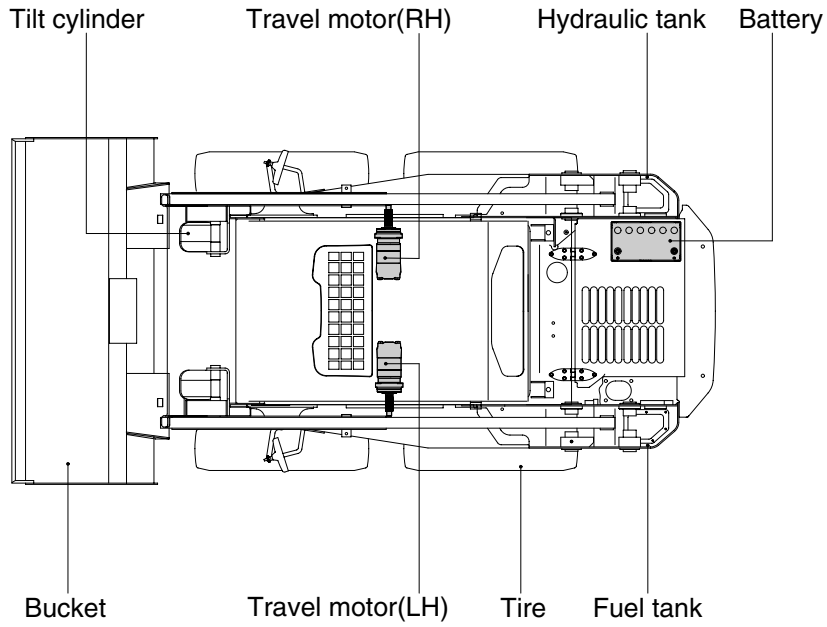

65072SP01

## 2. SPECIFICATIONS

### · WITH STANDARD BUCKET AND CANOPY

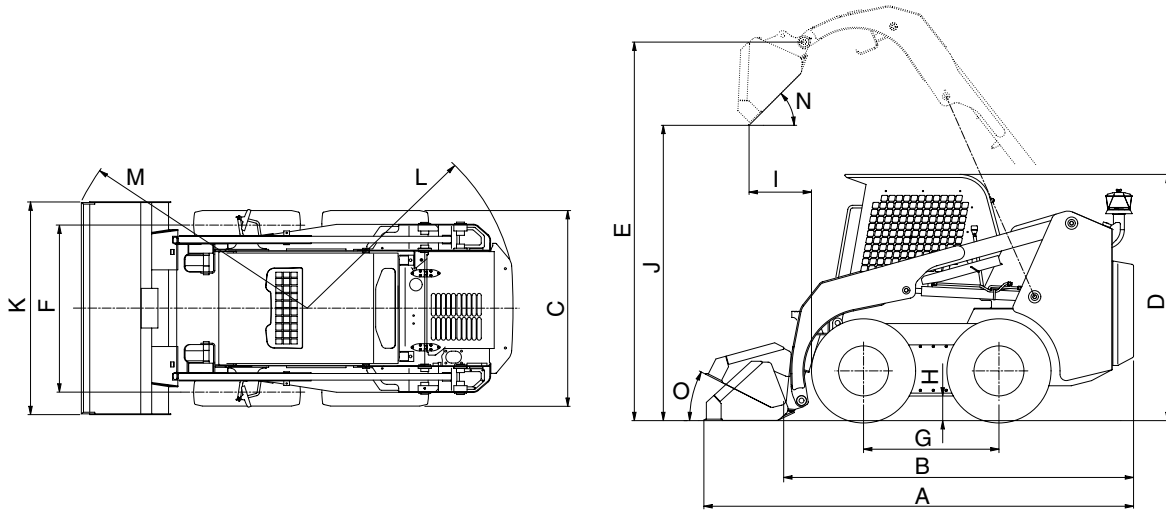

65072SP02A

Description		Unit	Specification	
Operating weight		kg(lb)	2625(5790)	
Bucket capacity	Struck	m <sup>3</sup> (yd <sup>3</sup> )	0.25(0.33)	
	Heaped		0.31(0.41)	
Overall length	A	mm(ft-in)	3270(10' 9")	
Overall length(Without bucket)	B		2625( 8' 7")	
Overall width(Except bucket)	C		1515( 5' 0")	
Overall height	D		1965( 6' 5")	
Overall height(To hinge pin)	E		2915( 9' 7")	
Tread	F		1255( 4' 1")	
Wheelbase	G		990( 3' 3")	
Ground clearance	H		183( 0' 7 ")	
Dump reach	I		550( 1' 10")	
Dump height	J		2240( 7' 4")	
Bucket width	K		1625( 5' 4")	
Clearance circle(Rear)	L		1560( 5' 1")	
Clearance circle(Front / bucket)	M		1920( 6' 4")	
Dump angle	N		Degree(°)	45
Roll back angle(Carry position)	O	27		
Cycle time	Boom	Up	sec	3.7
		Down		2.2
	Tilt	Dump		1.8
		Roll back		1.3
Maximum travel speed		km/hr(mph)	11.8(7.4)	
Minimum turning radius(Without bucket)		mm(ft-in)	1300(4' 3")	
Gradeability		Degree(°)	20	

### 3. WEIGHT

Item	HSL650-7	
	kg	lb
Frame assembly	760	1680
Canopy	164	362
Engine assembly	184	406
Main pump assembly	66.5	167
Main control valve	19	42
Travel motor	48	106
Boom	252	556
Bucket	180	399
Tire(10×16.5-6PR)	40	88
Boom cylinder	43	95
Bucket cylinder	24	53
Seat	9.6	21
Batter	20	44
Rear door assembly	58	128

## 4. SPECIFICATIONS FOR MAJOR COMPONENTS

### 1) ENGINE

Item	Specification
Model	Kubota V2203M DI
Type	4-cycle diesel engine
Cooling method	Water cooling
Number of cylinders and arrangement	4 cylinders, in-line
Combustion chamber type	Direct injection type
Cylinder bore × stroke	87 × 92.4mm
Piston displacement	2197cc
Compression ratio	20.5 : 1
Rated gross horse power	44.2ps at 2500rpm
Maximum gross torque	14kgf · m at 1600rpm
Engine oil quantity	7.6 l
Dry weight	184kg
High idling speed	less than 2750rpm
Low idling speed	1000 ± 25rpm
Rated fuel consumption	174g/ps · hr
Starting motor	12V-2.0kW
Alternator	12V-45AMP
Battery	1 × 12V × 72Ah(5Hr)

### 2) MAIN PUMP ASSY

Item	Specification	
	Main pump	Auxiliary pump
Type	Axial tandem piston pump	Fixed gear pump
Capacity	2 × 46cc/rev	28cc/rev
Maximum operation pressure	250kg/cm <sup>2</sup> (3560psi)	220kg/cm <sup>2</sup> (3130psi)
Rated speed	2400rpm	2400rpm

### 3) MAIN CONTROL VALVE

Item	Specification
Type	3 spool(Mono block)
Main relief valve pressure	175kgf/cm <sup>2</sup> (2490psi)

### 4) TRAVEL MOTOR

Item	Specification
Type	Fixed gear motor
Capacity	523.6cc/rev

### 5) CYLINDER

Item	Specification
Boom cylinder	Bore dia × Rod dia × Stroke ø 63 × ø 40 × 695mm
Bucket cylinder	Bore dia × Rod dia × Stroke ø 63 × ø 35 × 337mm

### 6) WHEELS

Item	Specification	
Tire	Tubeless type(STD)	10 × 16.5 - 6PR
	Tube type	7.5 × 16 - 12PR
	Solid type	8.25 × 15