

## 5. MAINTENANCE CHART

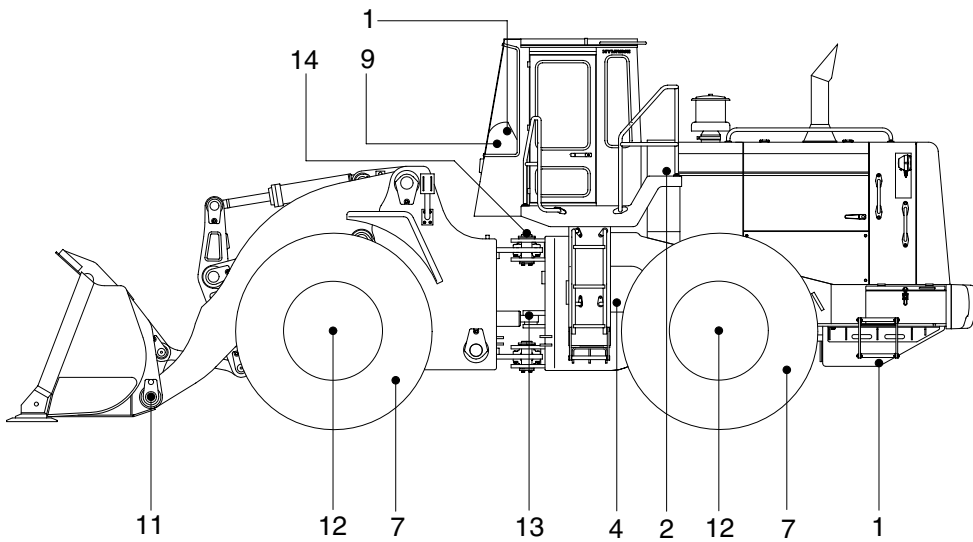
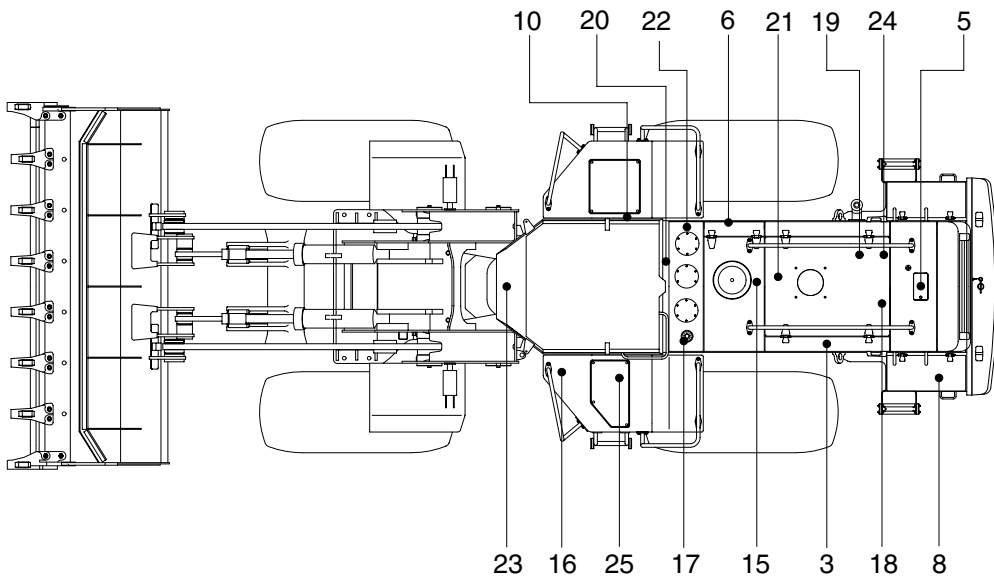

HL7803AM103

### Caution

1. Service intervals are based on the hour meter reading.
2. The number of each item shows the lubrication point on the machine.
3. Stop engine while filling oil, and use no open flames.
4. For other details, refer to the service manual.

Service interval	Item No.	Description	Service action	Oil symbol	Capacity / (U.S. gal)	Service points No.
10 Hours or daily	1	Fuel level (Fuel tank)	Check, Refill	DF	470(124)	1
	2	Hydraulic oil level	Check, Add	HO	185(48.9)	1
	3	Engine oil level	Check, Add	EO	38(10.0)	1
	4	Transmission oil level	Check, Add	EO	43(11.4)	1
	5	Radiator coolant level	Check, Add	C	65(17.2)	1
	6	Air cleaner element	Check, Clean			1
	7	Tire(Air)	Check, Add			4
	8	Battery(Electrolyte)	Check, Add			2
	9	Warning lamps	Check, Clean			1
50 Hours or weekly	10	Air conditioner and heater outer filter	Check, Clean			1
	11	Attachment pins	Lubricate	PGL		13
	23	Drive shafts(Front, center)	Lubricate	PGL		5
100 Hours	12	Axle oil level	Check, Add	GO	120(31.7)	6
	13	Steering cylinder pins	Lubricate	PGL		4
	14	Center pivot pin	Lubricate	PGL		2
	15	Rear axle pivot pin	Lubricate	PGL		2
250 Hours	1	Fuel tank(Water, sediment)	Drain	DF	470(124)	1
	3	Engine oil	Change	EO	38(10.1)	1
	6	Air cleaner element	Replace			1
	7	Tire(Wheel hub bolt)	Check, Tight			4
	17	Hydraulic air breather element	Replace			1
	18	Fan belt tension	Check, Clean			3
	19	Fuel filter element	Replace			2
	20	Pilot line filter	Replace			1
	21	Engine oil filter	Replace			1
	22	Hydraulic return oil filter	Replace			3
	24	Corrosion resistor	Replace			1
25	Brake line filter	Check, Clean			1	
500 Hours	16	Transmission oil filter	Replace			2
1000 Hours	4	Transmission oil	Change	ED	43(11.4)	1
	12	Axle oil	Change	GO	120(31.7)	6
	10	Air conditioner and heater outer filter	Replace			1
2000 Hours	2	Hydraulic oil	Change	HO	185(48.9)	1
	5	Radiator coolant	Change	C	65(17.2)	1

※ **Oil symbol**

Refer the recommended lubricants for specification.

- EO : Engine oil
- HO : Hydraulic oil
- DF : Diesel fuel
- GO : Gear oil
- PGL : Grease
- C : Coolant