

5. MAINTENANCE CHART

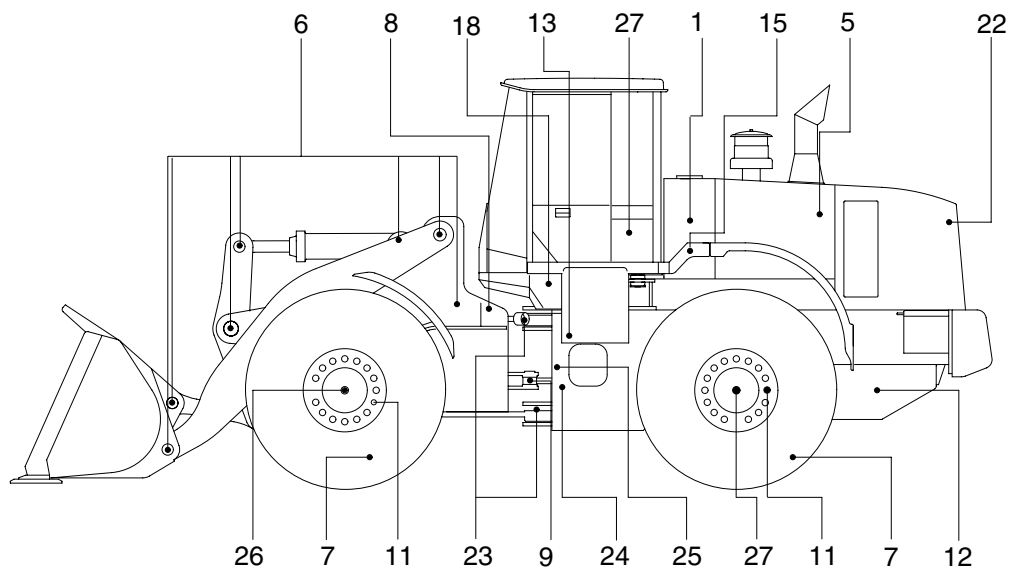
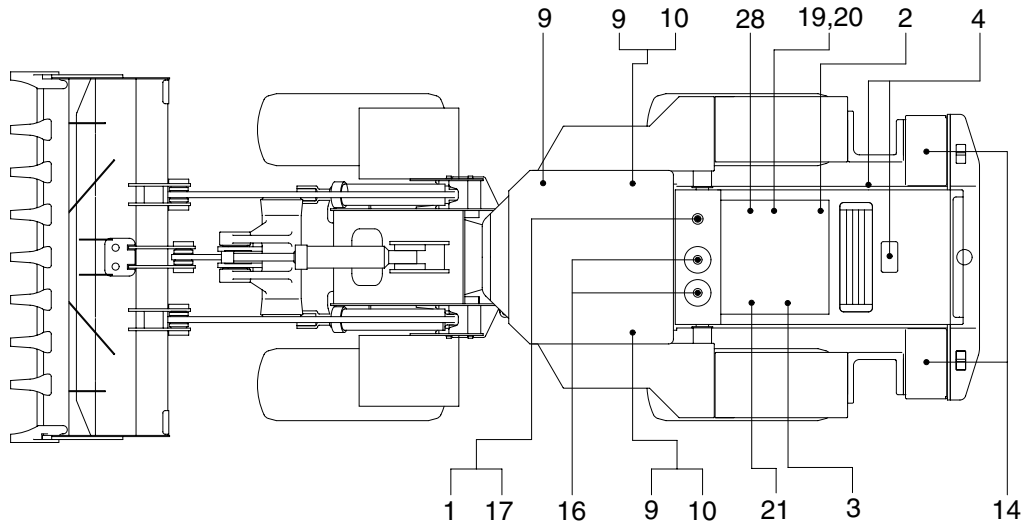

77096M110

Caution

1. Service intervals are based on the hour meter reading.
2. The number of each item shows the lubrication point on the machine.
3. Stop engine while filling oil, and use no open flames.
4. For other details, refer to the service manual.

Service interval	No.	Description	Service action	Oil symbol	Capacity l (U.S.gal)	Service points No.
10 Hours or daily	1	Hydraulic oil level	Check, Add	HO	200 (52.9)	1
	2	Engine oil level	Check, Add	EO	23 (6.1)	1
	4	Radiator coolant level	Check, Add	C	56 (14.8)	1
	5	Fan belt tension & damage	Check, Adjust	-	-	2
	20	Fuel pre-filter	Clean	-	-	1
50 Hours or weekly	6	Attachment pins	Lubricate	PGL	-	13
	7	Tire (air)	Check, Add	-	-	4
	8	Drive shaft (front, center)	Lubricate	PGL	-	2
	9	Steering cylinder pin	Lubricate	PGL	-	4
	10	Rear axle pivot	Lubricate	PGL	-	2
250 Hours	11	Wheel nuts	Check, Tight	-	-	80
	12	Fuel tank (water, sediment)	Drain	-	475 (120.7)	1
	14	Battery (voltage)	Check, Add	-	-	2
	17	Hydraulic tank air breather element	Replace	-	-	1
	28	Air conditioner and heater outer filter	Check, Clean	-	-	1
500 Hours	2	Engine oil	Change	EO	23 (6.1)	1
	3	Engine oil filter	Replace	-	-	1
	19	Fuel filter element	Replace	-	-	1
	20	Fuel pre-filter element	Replace	-	-	1
	21	Coolant filter	Replace	-	-	1
	22	Radiator, oil cooler, charge air cooler	Clean	-	-	3
	29	Air cleaner element (primary)	Clean	-	-	1
1000 Hours	13	Brake line filter element	Replace	-	-	1
	16	Hydraulic oil return filter	Replace	-	-	2
	18	Pilot line filter element	Replace	-	-	1
	23	Center pivot pin	Lubricate	PGL	-	2
	24	Transmission oil	Change	EO	43 (11.4)	1
	25	Transmission oil filter	Replace	-	-	2
1500 Hours	26	Axle oil (front)	Change	UTTO	51 (13.5)	3
	27	Axle oil (rear)	Change	UTTO	43 (11.4)	3
2000 Hours	1	Hydraulic oil *1	Change	HO	200 (52.9)	1
	4	Radiator coolant	Change	C	56 (14.8)	1
	15	Hydraulic oil suction strainer	Check, Clean	-	-	1
5000 Hours	1	Hydraulic oil *2	Change	HO	200 (52.9)	1
When required	28	Air conditioner and heater outer filter	Replace	-	-	1
		Air conditioner and heater inner filter	Clean, Replace	-	-	1
	29	Air cleaner element (safety and primary)	Clean, Replace	-	-	2

*1 Conventional hydraulic oil *2 Hyundai genuine long life hydraulic oil

※ **Oil symbol**

Refer the recommended lubricants for specification.

- EO : Engine oil
- HO : Hydraulic oil
- GO : Gear oil
- PGL : Grease
- C : Coolant
- UTTO : Refer to the page 6-9.