

## 5. MAINTENANCE CHART

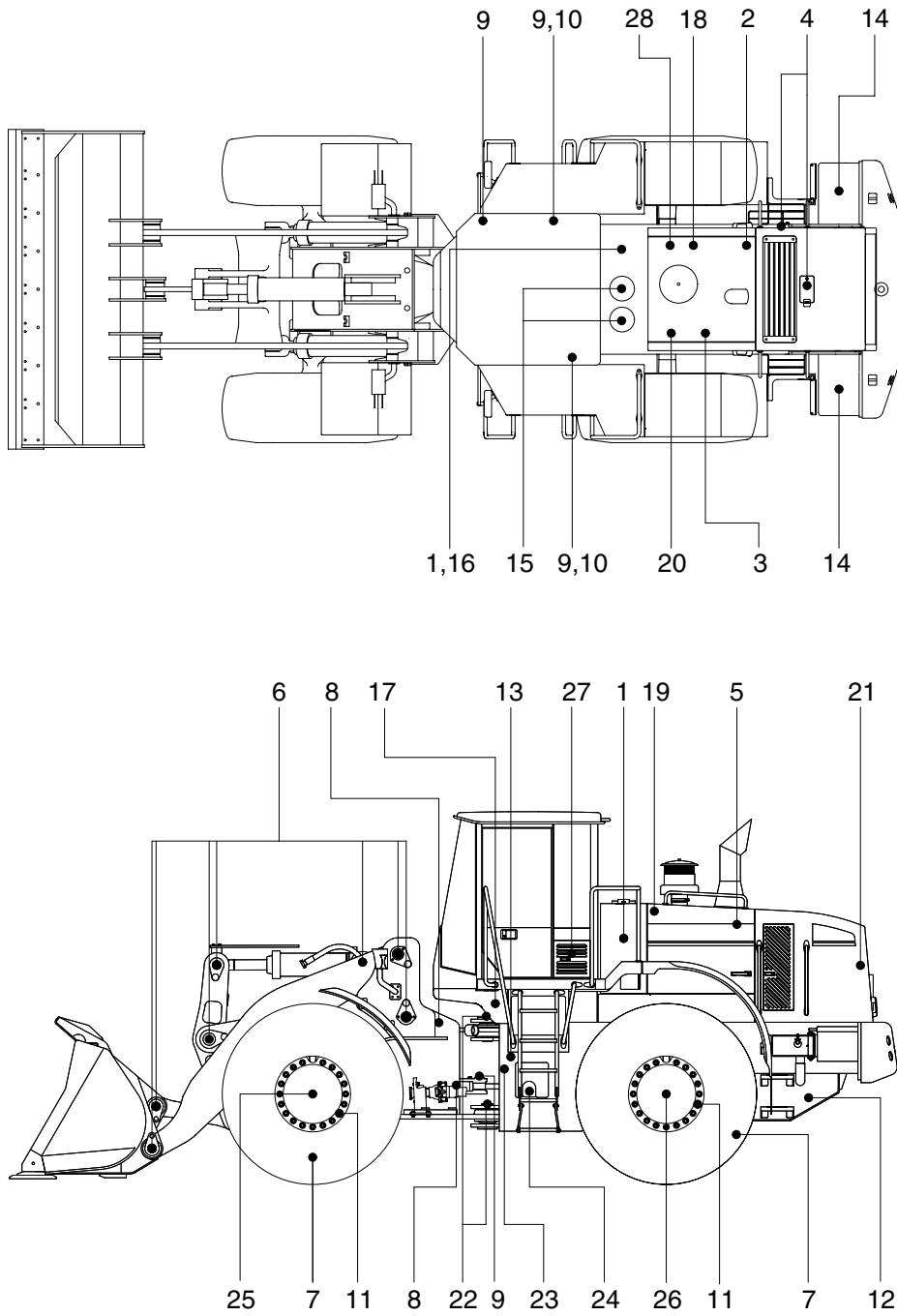

7707A6MI34

### Caution

1. Service intervals are based on the hour meter reading.
2. The number of each item shows the lubrication point on the machine.
3. Stop engine while filling oil, and use no open flames.
4. For other details, refer to the service manual.

Service interval	Item No.	Description	Service action	Oil symbol	Capacity / (U.S. gal)	Service points No.
10 Hours or daily	1	Hydraulic oil level	Check, Add	HO	200(52.9)	1
	2	Engine oil level	Check, Add	EO	23(6.1)	1
	4	Radiator coolant level	Check, Add	C	56(14.8)	1
	5	Belt tension & damage	Check			1
	19	Fuel pre-filter	Clean			1
50 Hours or weekly	6	Attachment pins	Lubricate	PGL		13
	7	Tire(Air)	Check, Add			4
	8	Drive shaft(Front, center)	Lubricate	PGL		2
	9	Steering cylinder pins	Lubricate	PGL		4
	10	Rear axle pivot	Lubricate	PGL		2
	11	Wheel nuts	Check, Tight			76
250 Hours	12	Fuel tank(Water, sediment)	Drain			1
	13	Brake line filter(Strainer)	Check, Clean			1
	14	Battery(Voltage)	Check, Add			2
	15	Hydraulic oil return filter(~#0262)	Replace			2
	16	Hydraulic tank air breather element	Replace			1
	17	Pilot line filter element(~#0262)	Replace			1
	27	Air conditioner and heater outer filter	Check, Clean			1
500 Hours	2	Engine oil	Change	EO	23(6.1)	1
	3	Engine oil filter	Replace			1
	18	Fuel filter element	Replace			2
	19	Fuel pre-filter	Replace			1
	20	Corrosion resistor	Replace			1
	21	Radiator, oil cooler, charge air cooler	Clean			3
	28	Air cleaner element(Primary)	Clean			1
1000 Hours	15	Hydraulic oil return filter(#0263~)	Replace			2
	17	Pilot line filter element(#0263~)	Replace			1
	22	Center pivot pin	Lubricate	PGL		2
	23	Transmission oil	Change	EO	50(13.2)	1
	24	Transmission oil filter	Replace			2
1500 Hours	25	** Front axle oil (VOLVO axle)	Change	GO	78(20.6)	3
		** Front axle oil (ZF axle)	Change	UTTO	51(13.5)	3
	26	** Rear axle oil (VOLVO axle)	Change	GO	53(14.0)	3
		** Rear axle oil (ZF axle)	Change	UTTO	43(11.4)	3
2000 Hours	1	Hydraulic oil	Change	HO	200(52.8)	1
	4	Radiator coolant	Change	C	56(14.8)	1
When required	27	Air conditioner and heater outer filter	Replace			1
		Air conditioner and heater inner filter	Clean, Replace			1
	28	Air cleaner element(Safety)	Replace			1
		Air cleaner element(Primary)	Replace			1

※ Oil symbol

Refer to the recommended lubricants for specification.

- EO : Engine oil
- PGL : Grease
- GO : Gear oil
- HO : Hydraulic oil
- C : Coolant

\*\* Machine serial No. : Refer to page 6-8.