

5. MAINTENANCE CHART

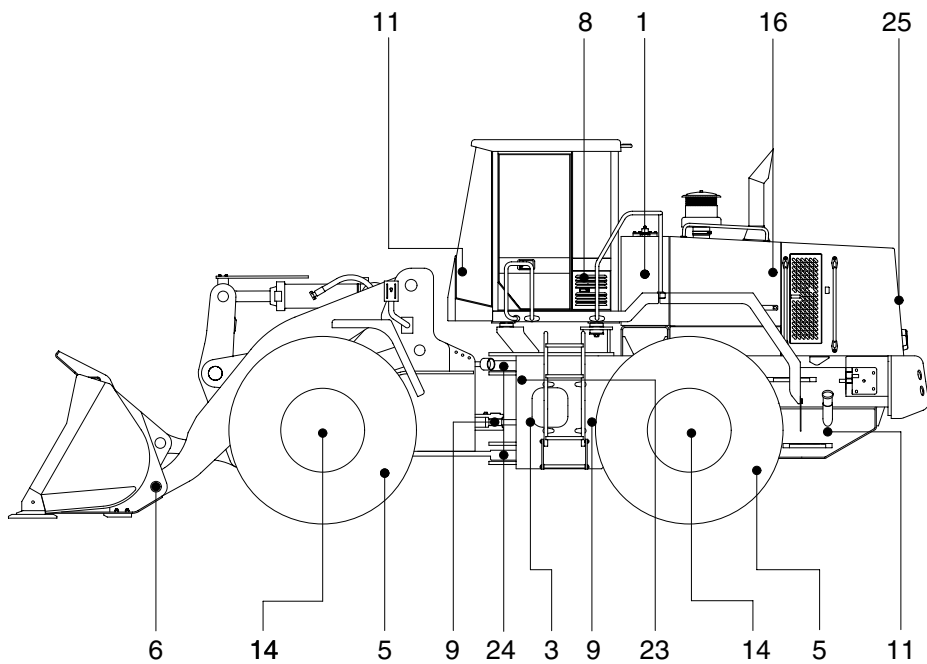
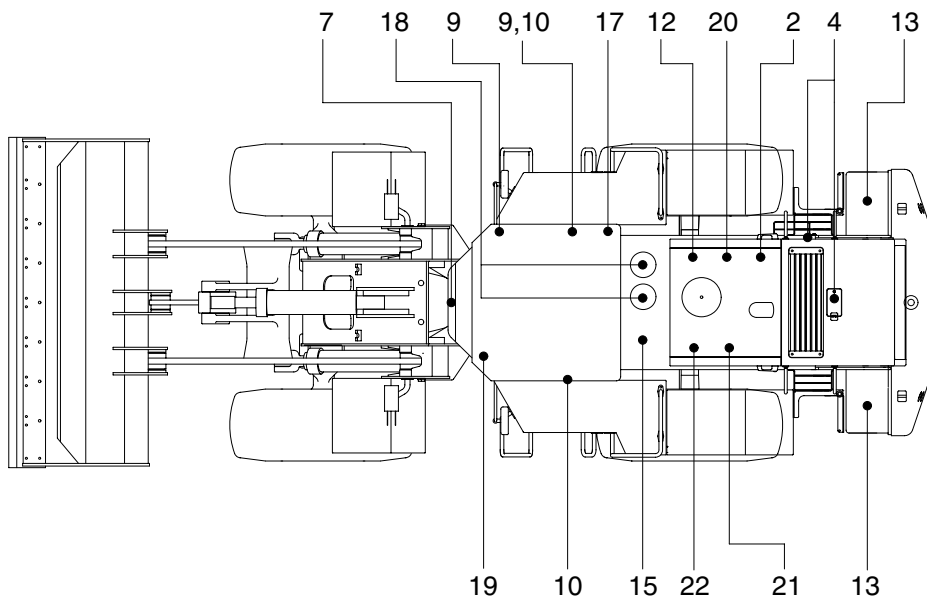

77076MI34

Caution

1. Service intervals are based on the hour meter reading.
2. The number of each item shows the lubrication point on the machine.
3. Stop engine while filling oil, and use no open flames.
4. For other details, refer to the service manual.

Service interval	Item No.	Description	Service action	Oil symbol	Capacity / (U.S. gal)	Service points No.
10 Hours or daily	1	Hydraulic oil level	Check, Add	HO	320(85)	1
	2	Engine oil level	Check, Add	EO	20(5.3)	1
	3	Transmission oil level	Check, Add	EO	55(14.5)	1
	4	Radiator coolant level	Check, Add	C	56(14.8)	1
	5	Tire(Air)	Check, Add			4
50 Hours or weekly	6	Attachment pins	Lubricate	PGL		13
	7	Drive shaft(Front, center)	Lubricate	PGL		2
	9	Steering cylinder pin	Lubricate	PGL		4
	10	Rear axle pivot pin	Lubricate	PGL		2
250 Hours	8	Cab fresh air filter(Outer filter)	Check, Clean			1
	11	Fuel tank(Water, sediment)	Drain			1
	13	Battery(Electrolyte)	Check, Add			2
	14	Axle oil level	Check, Add			6
	15	Hydraulic air breather element	Replace	GO	131(34.6)	1
	16	Belt tension	Check, Adjust			2
	17	Pilot line filter element	Replace			1
	18	Hydraulic return oil filter	Replace			2
	19	Brake line filter strainer	Check, Clean			1
500 Hours	2	Engine oil	Change	EO	20(5.3)	1
	12	Air cleaner element	Clean			2
	20	Fuel filter element	Replace			1
	21	Engine oil filter	Replace			1
	22	Corrosion resistor	Replace			1
	25	Radiator and cooler fin	Check, clean			1
1000 Hours	3	Transmission oil	Change	EO	55(14.5)	1
	23	Transmission oil filter	Replace			2
	24	Center pivot pin	Change	PGL		2
1500 Hours	14	Axle oil	Change	GO	131(34.6)	6
2000 Hours	1	Hydraulic oil	Change	HO	320(85)	1
	4	Radiator coolant	Change	C	56(14.8)	1
When required	5	Tire(Wheel hub nut)	Check, Tight			4
	8	Cab fresh air filter(Inner and outer filter)	Clean, Replace			2
	12	Air cleaner element	Clean, Replace			2
	16	Belt	Replace			2
	25	Radiator and cooler fin	Check, Clean			1

※ **Oil symbol**

Refer the recommended lubricants for specification.

- EO : Engine oil
- HO : Hydraulic oil
- GO : Gear oil
- PGL : Grease
- C : Coolant