

## 2. SPECIFICATIONS

### 1) WITH BOLT-ON CUTTING EDGE TYPE BUCKET (HL760-9)

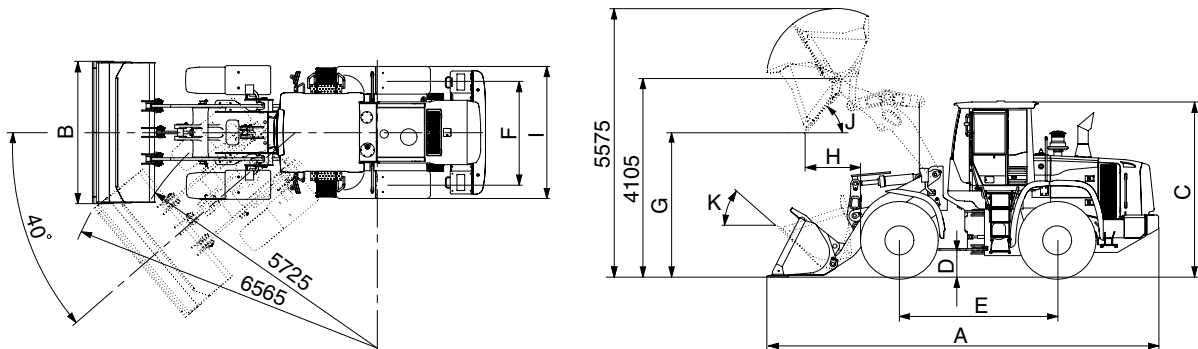

76092SE03

Description		Unit	Specification	
Operating weight		kg (lb)	17900 (39460)	
Bucket capacity	Struck	m <sup>3</sup> (yd <sup>3</sup> )	2.8 (3.7)	
	Heaped		3.3 (4.3)	
Overall length	A	mm (ft-in)	8100 (26' 7")	
Overall width	B		2900 (9' 6")	
Overall height	C		3450 (11' 4")	
Ground clearance	D		420 (1' 5")	
Wheelbase	E		3300 (10' 10")	
Tread	F		2160 (7' 1")	
Dump clearance at 45°	G		2970 (9' 9")	
Dump reach (full lift)	H		1220 (4' 0")	
Width over tires	I		2770 (9' 1")	
Dump angle	J		degree (°)	47
Roll back angle (carry position)	K			47
Cycle time	Lift (with load)	sec	5.8	
	Dump (with load)		1.2	
	Lower (empty)		3.1	
Maximum travel speed		km/hr (mph)	38.0 (23.7)	
Braking distance		m (ft-in)	13 (42' 7")	
Minimum turning radius (center of outside tire)			5.73 (18' 9")	
Gradeability		degree (°)	30	
Travel speed	Forward	First gear	6.3 (3.9)	
		Second gear	12.0 (7.5)	
		Third gear	24.0 (15.0)	
		Fourth gear	38.1 (23.7)	
	Reverse	First gear	6.7 (4.2)	
		Second gear	12.6 (7.9)	
Third gear		25.2 (15.7)		

**WITH BOLT-ON CUTTING EDGE TYPE BUCKET (HL760XTD-9)**

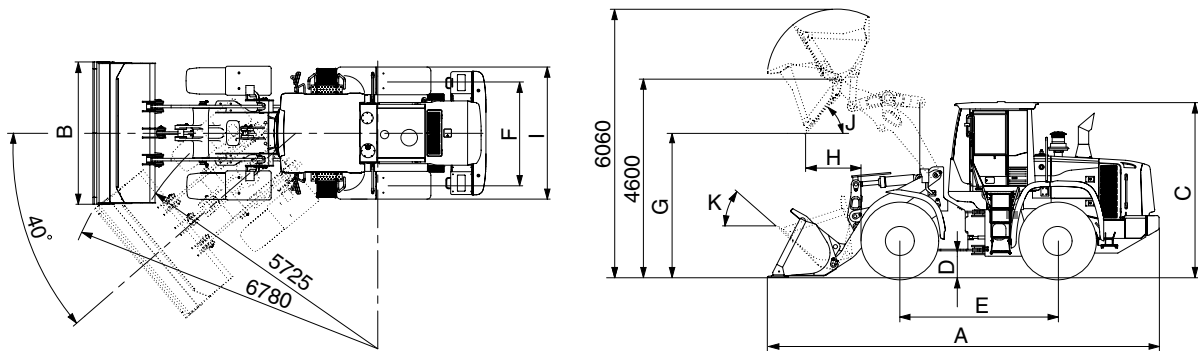

76092SE03-1

Description		Unit	Specification	
Operating weight		kg (lb)	18700 (41230)	
Bucket capacity	Struck	m <sup>3</sup> (yd <sup>3</sup> )	2.8 (3.7)	
	Heaped		3.3 (4.3)	
Overall length	A	mm (ft-in)	8660 (28' 5")	
Overall width	B		2900 (9' 6")	
Overall height	C		3450 (11' 4")	
Ground clearance	D		420 (1' 5")	
Wheelbase	E		3300 (10' 10")	
Tread	F		2160 (7' 1")	
Dump clearance at 45°	G		3460 (11' 4")	
Dump reach (full lift)	H		1235 (4' 1")	
Width over tires	I		2770 (9' 1")	
Dump angle	J		degree (°)	47
Roll back angle (carry position)	K			49
Cycle time	Lift (with load)	sec	5.8	
	Dump (with load)		1.2	
	Lower (empty)		3.1	
Maximum travel speed		km/hr (mph)	38.0 (23.7)	
Braking distance		m (ft-in)	13 (42' 7")	
Minimum turning radius (center of outside tire)			5.73 (18' 9")	
Gradeability		degree (°)	30	
Travel speed	Forward	First gear	6.3 (3.9)	
		Second gear	12.0 (7.5)	
		Third gear	24.0 (15.0)	
	Reverse	Fourth gear	38.1 (23.7)	
		First gear	6.7 (4.2)	
		Second gear	12.6 (7.9)	
			25.2 (15.7)	

2) WITH TOOTH TYPE BUCKET (HL760-9)

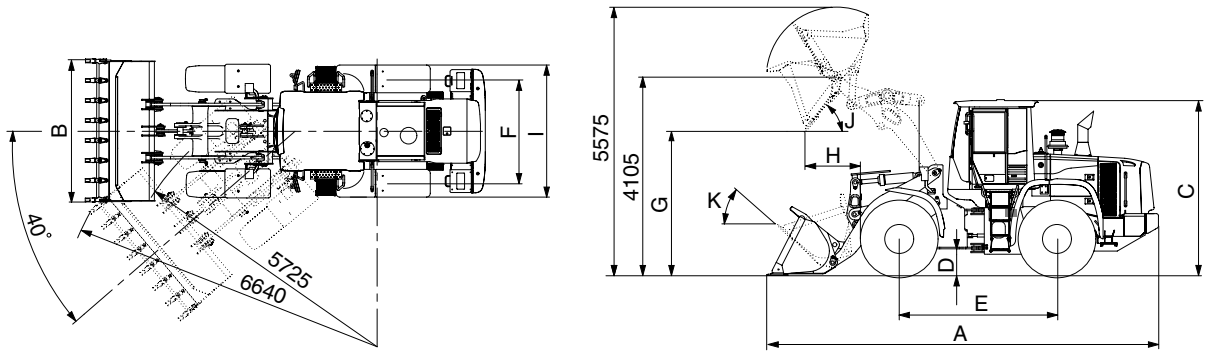

76092SE02

Description		Unit	Specification	
Operating weight		kg (lb)	17900 (39460)	
Bucket capacity	Struck	m <sup>3</sup> (yd <sup>3</sup> )	2.7 (3.5)	
	Heaped		3.2 (4.2)	
Overall length	A	mm (ft-in)	8255 (27' 1")	
Overall width	B		2950 (9' 8")	
Overall height	C		3450 (11' 4")	
Ground clearance	D		420 (1' 5")	
Wheelbase	E		3300 (10' 10")	
Tread	F		2160 (7' 1")	
Dump clearance at 45°	G		2845 (9' 4")	
Dump reach (full lift)	H		1305 (4' 3")	
Width over tires	I		2770 (9' 1")	
Dump angle	J		degree (°)	47
Roll back angle (carry position)	K			47
Cycle time	Lift (with load)	sec	5.8	
	Dump (with load)		1.2	
	Lower (empty)		3.1	
Maximum travel speed		km/hr (mph)	38.0 (23.7)	
Braking distance		m (ft-in)	13 (42' 7")	
Minimum turning radius (center of outside tire)			5.73 (18' 9")	
Gradeability		degree (°)	30	
Travel speed	Forward	First gear	6.3 (3.9)	
		Second gear	12.0 (7.5)	
		Third gear	24.0 (15.0)	
		Fourth gear	38.1 (23.7)	
	Reverse	First gear	6.7 (4.2)	
		Second gear	12.6 (7.9)	
Third gear		25.2 (15.7)		

**WITH TOOTH TYPE BUCKET (HL760XTD-9)**

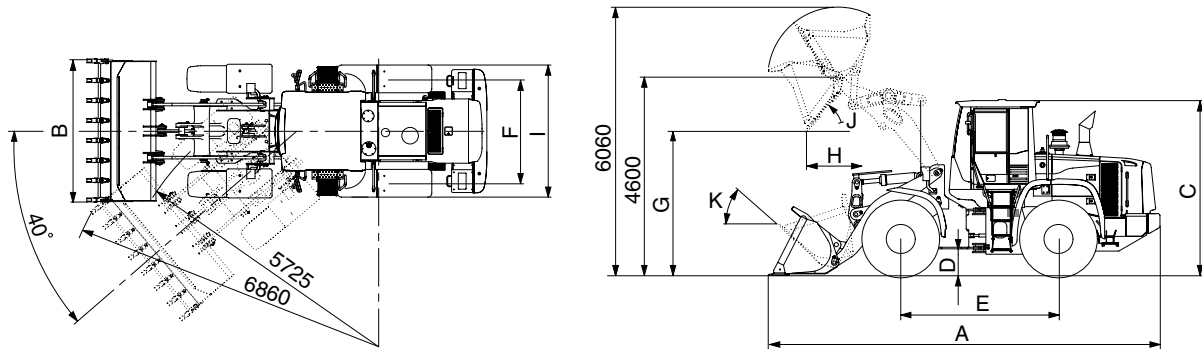

76092SE02-1

Description		Unit	Specification	
Operating weight		kg (lb)	18700 (41320)	
Bucket capacity	Struck	m <sup>3</sup> (yd <sup>3</sup> )	2.7 (3.5)	
	Heaped		3.2 (4.2)	
Overall length	A	mm (ft-in)	8820 (28' 11")	
Overall width	B		2950 (9' 8")	
Overall height	C		3450 (11' 4")	
Ground clearance	D		420 (1' 5")	
Wheelbase	E		3300 (10' 10")	
Tread	F		2160 (7' 1")	
Dump clearance at 45°	G		3335 (10' 11")	
Dump reach (full lift)	H		1330 (4' 4")	
Width over tires	I		2770 (9' 1")	
Dump angle	J		degree (°)	47
Roll back angle (carry position)	K			49
Cycle time	Lift (with load)	sec	5.8	
	Dump (with load)		1.2	
	Lower (empty)		3.1	
Maximum travel speed		km/hr (mph)	38.0 (23.7)	
Braking distance		m (ft-in)	13 (42' 7")	
Minimum turning radius (center of outside tire)			5.73 (18' 9")	
Gradeability		degree (°)	30	
Travel speed	Forward	First gear	6.3 (3.9)	
		Second gear	12.0 (7.5)	
		Third gear	24.0 (15.0)	
		Fourth gear	38.1 (23.7)	
	Reverse	First gear	6.7 (4.2)	
		Second gear	12.6 (7.9)	
Third gear		25.2 (15.7)		