

5. MAINTENANCE CHART

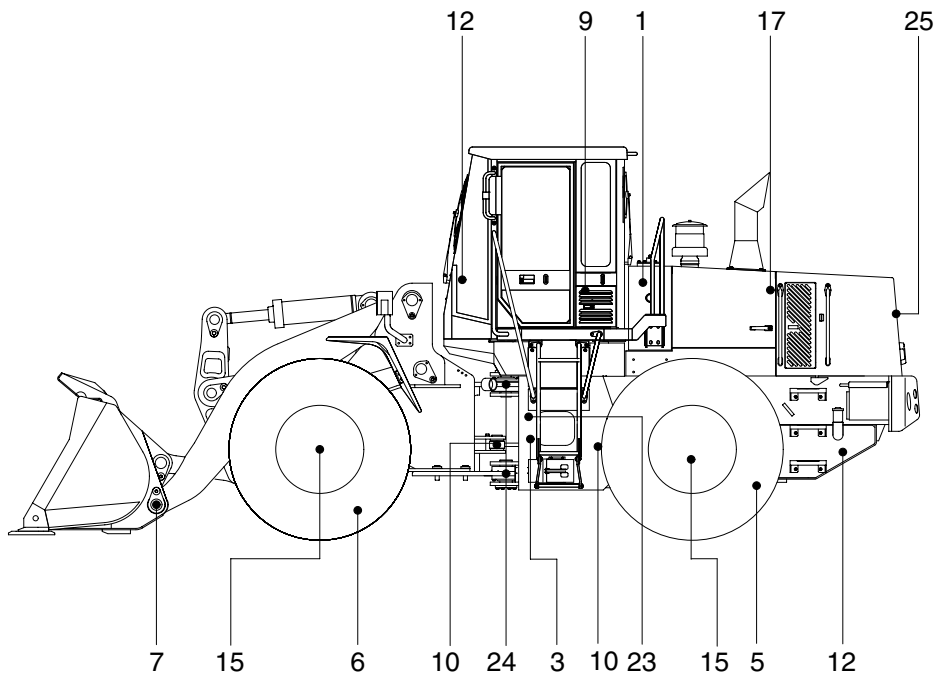
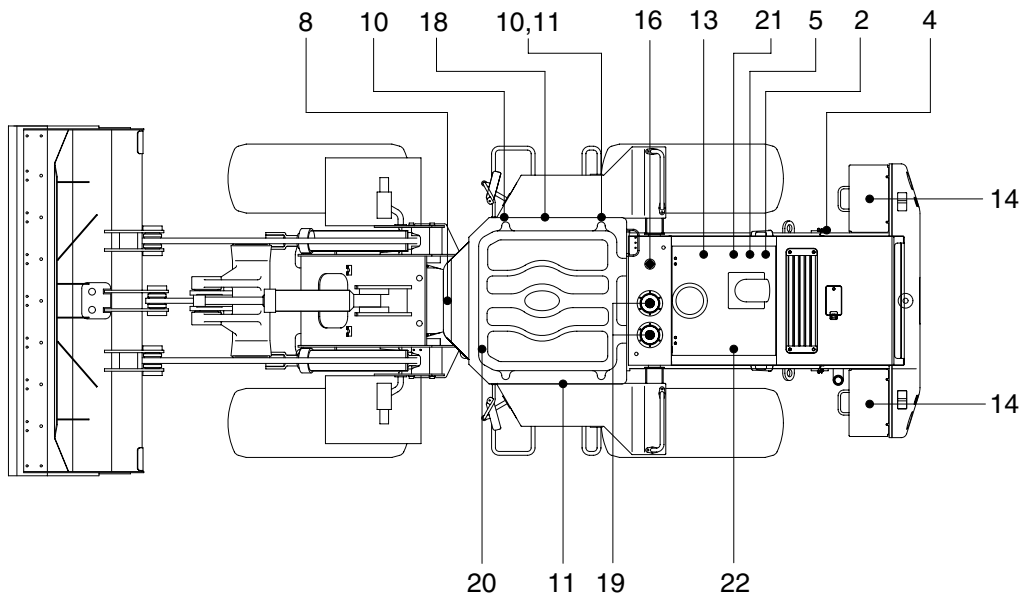

76076M123

Caution

1. Service intervals are based on the hour meter reading.
2. The number of each item shows the lubrication point on the machine.
3. Stop engine while filling oil, and use no open flames.
4. For other details, refer to the service manual.

Service interval	Item No.	Description	Service action	Oil symbol	Capacity / (U.S. gal)	Service points No.
10 Hours or daily	1	Hydraulic oil level	Check, Add	HO	260(69)	1
	2	Engine oil level	Check, Add	EO	16(4.2)	1
	3	Transmission oil level	Check, Add	EO	32(8.5)	1
	4	Radiator coolant level	Check, Add	C	40(10.6)	1
	5	Fuel pre-filter(Water, sediment)	Check, Clean			1
	6	Tire(Air)	Check, Add			4
100 Hours	7	Attachment pins	Lubricate	PGL		13
	8	Drive shaft(Front, center)	Lubricate	PGL		2
	10	Steering cylinder pin	Lubricate	PGL		4
	11	Rear axle pivot pin	Lubricate	PGL		2
250 Hours	9	Cab fresh air filter(Outer filter)	Check, Clean			1
	12	Fuel tank(Water, sediment)	Drain		330(87.2)	1
	14	Battery(Electrolyte)	Check, Add			2
	15	Axle oil level	Check, Add	GO		6
	16	Hydraulic air breather element	Replace			1
	17	Belt tension	Check, Adjust			2
	18	Pilot line filter element	Replace			1
	19	Hydraulic return oil filter	Replace			2
500 Hours	2	Engine oil	Change	EO	16(4.2)	1
	13	Air cleaner element	Clean			2
	21	Fuel filter element	Replace			1
	22	Engine oil filter	Replace			1
	25	Radiator and cooler fin	Check, Clean			1
1000 Hours	3	Transmission oil	Change	EO	32(8.5)	1
	23	Transmission oil filter	Replace			2
	24	Center pivot pin	Lubricate	PGL		2
1500 Hours	15	Axle oil	Change	GO	85(22.5)	6
2000 Hours	1	Hydraulic oil	Change	HO	260(69)	1
	4	Radiator coolant	Change	C	40(10.6)	1
When required	6	Tire(Wheel hub nut)	Check, Tight			4
	9	Cab fresh air filter(Inner & Outer filter)	Clean, Replace			2
	13	Air cleaner element	Clean, Replace			2
	17	Belt	Replace			2
	25	Radiator and cooler fin	Check, Clean			1

※ **Oil symbol**

Refer the recommended lubricants for specification.

- EO : Engine oil
- HO : Hydraulic oil
- GO : Gear oil
- PGL : Grease
- C : Coolant