

3. STARTING AND STOPPING THE ENGINE

1) CHECK INDICATOR LIGHTS

- (1) Check if parking brake switch is ON.
- (2) Check if gear selector lever is in neutral position.
- (3) Check if hydraulic safety lever is in the lock position.
- (4) Turn the key to the ON position, and check following.
 - ① If all the lamps light ON after sounding buzzer for 3 seconds.
 - ※ **If the lamps do not light or the buzzer is not sounded, check disconnection of wire.**
 - ② Only below lamps will light ON and all the other light will be turn OFF after 3 seconds.
 - Charging warning lamp(1)
 - Engine oil pressure warning lamp(2)
 - Brake fail warning lamp(3)
 - ※ **Start the engine after all of the lamps OFF. (Only above 3 lamps remain ON)**
 - ※ **Refer to 「START PROCEDURE」 of page 0-11.**

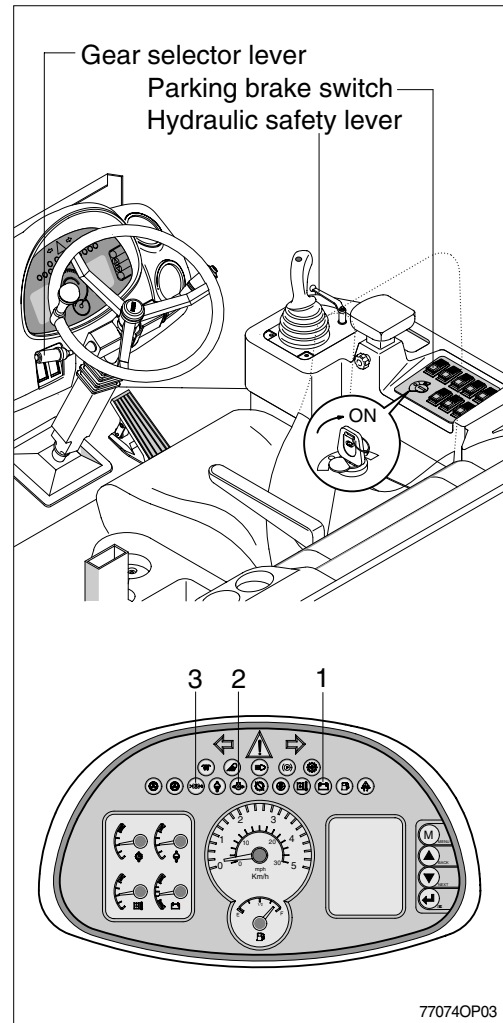

2) STARTING ENGINE IN NORMAL TEMPERATURE

- ※ **Sound the horn to warn the surroundings after checking if personnel or obstacles are in the area.**
- (1) Turn the starting switch to START position to start the engine.
 - ※ **If the engine does not start, allow the starter to cool for about 2 minutes before attempting to start the engine again.**
 - (2) Release the starting switch instantly after the engine starts to avoid possible damage to the starting motor.

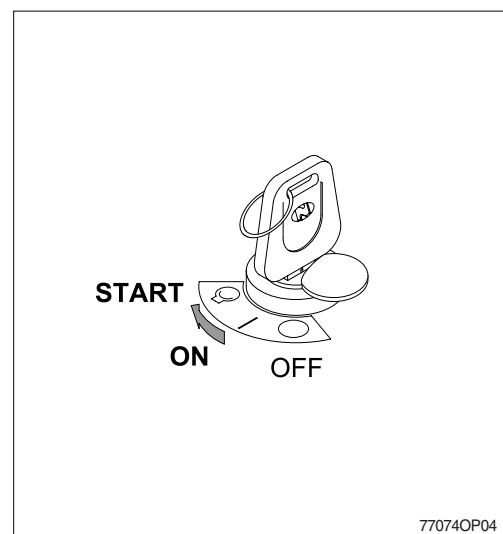

3) STARTING ENGINE IN A COLD WEATHER

Sound horn to warn surroundings after checking if there are obstacles in the area.

Replace the engine oil and fuel referring to recommended oils at page 6-9.

Fill the anti-freeze solution to the coolant as required.

- (1) Check if the parking brake is locked(With the parking switch ON).
- (2) Check if the gear selector lever is in the neutral position.
- (3) Check if the hydraulic safety lock lever is in the lock position.
- (4) Turn the starting switch to ON position, and wait the preheater pilot lamp OFF.

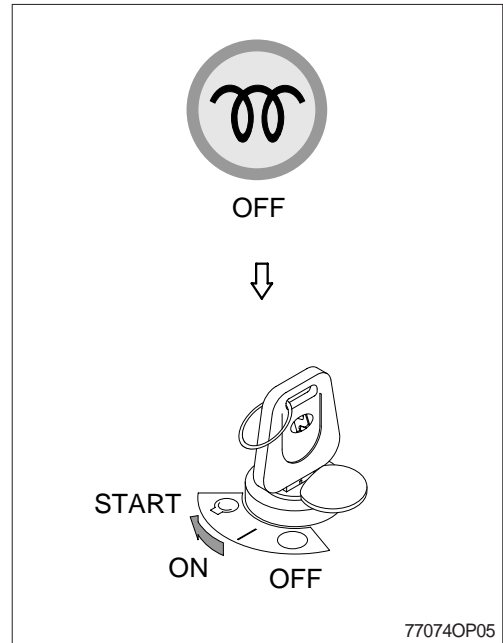

When the preheater warning lamp is turned ON, the preheating function is actuated within 10~45 seconds in accordance with temperature of the air intake manifold.

- (5) Start the engine by turning the starting switch to START position after the preheater pilot lamp OFF.
- (6) Release starting switch immediately after starting engine. The starting switch will automatically return to the ON position.

After engine started, the preheating function is actuated to reduce the white smoke.

4) INSPECTION AFTER ENGINE START

Inspect and confirm the following after engine starts.

- (1) Is the level gauge of hydraulic oil tank in the normal level?
- (2) Are there leakages of oil or water?
- (3) Are all the warning lamps(1-13) OFF?
- (4) Check the following after warming up operation.
 - Is the indicator of water temperature gauge (14) in the operating range?
 - Is the indicator of transmission oil temperature gauge(15) in the operating range?
 - Is the engine sound and the color of exhaust gas normal?
 - Are the sound and vibration normal?

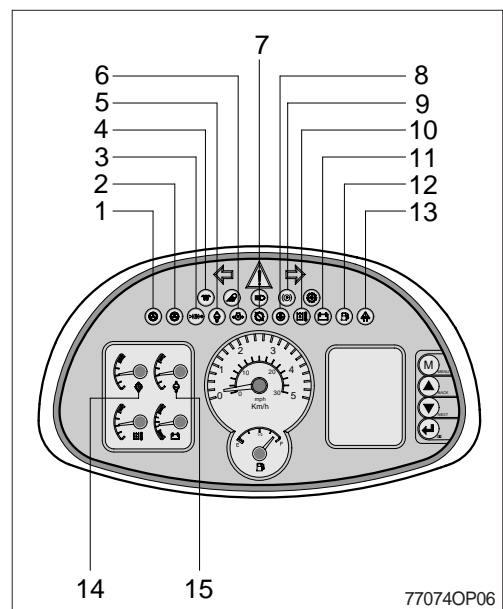

Do not increase engine speed quickly after starting, it can make damage engine or turbocharger.

If there are problems in the control panel, stop the engine immediately and correct problem as required.

5) TRANSMISSION COLD STARTING

- (1) At an oil temperature in the shifting circuit $< -12^{\circ}\text{C}$, the transmission must be warmed-up for some minutes.
- (2) This must be carried out in neutral with an increased engine speed.
- (3) Until this oil temperature is reached, the electronics remains in neutral, and the symbol of the cold start phase will be indicated on the display.
 - Indication on the display : * *
- (4) After the indication on the display is extinguished, the full driving programm can be utilized out of NEUTRAL.

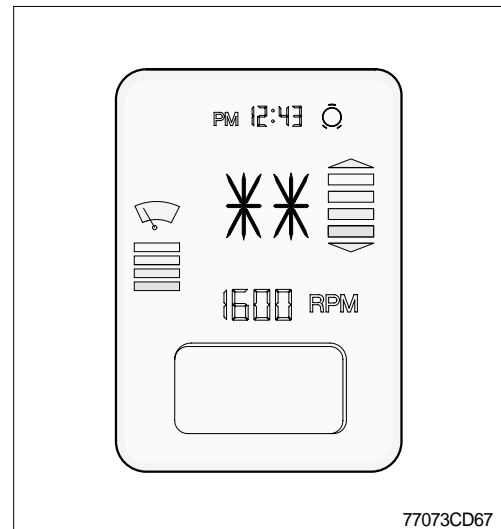

6) TO STOP THE ENGINE

If the engine is abruptly stopped before it has cooled down, engine life may be greatly shortened. Consequently, do not abruptly stop the engine apart from an emergency. In particularly if the engine has overheated, do not abruptly stop it but run it at medium speed to allow it to cool gradually, then stop it.

- (1) Place the gear selector lever in neutral.
- (2) Turn the parking brake switch ON.
- (3) Run the engine for five minutes at low idle with no load.
- (4) Return the key of starting switch to the OFF position.
- (5) Remove the key to prevent other people using the machine and LOCK safety lever.
- (6) Lock the cab door.

