

2. SPECIFICATIONS

1. MAJOR COMPONENTS

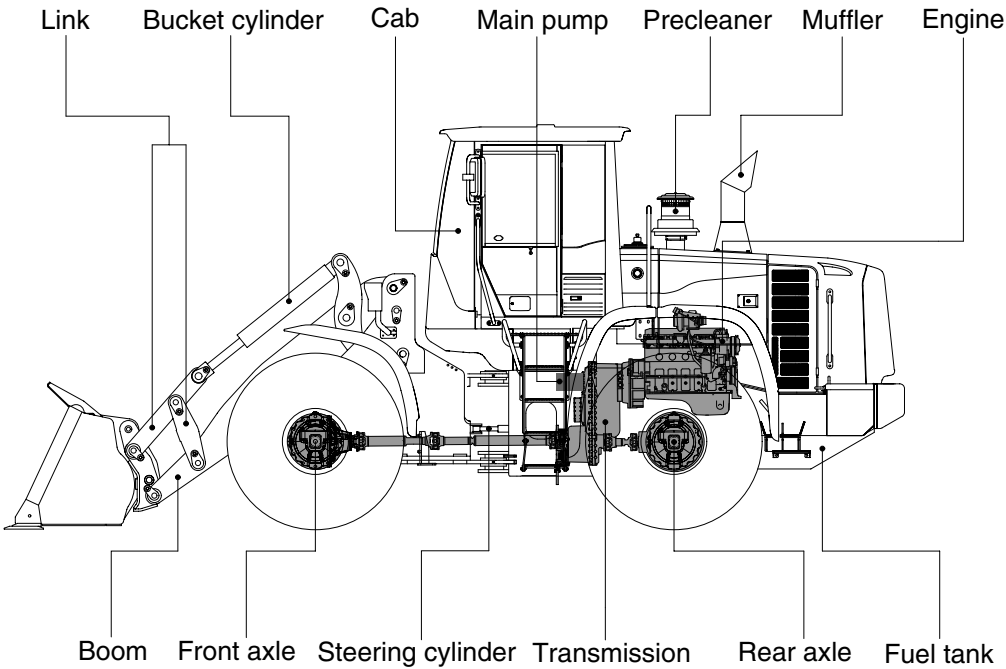
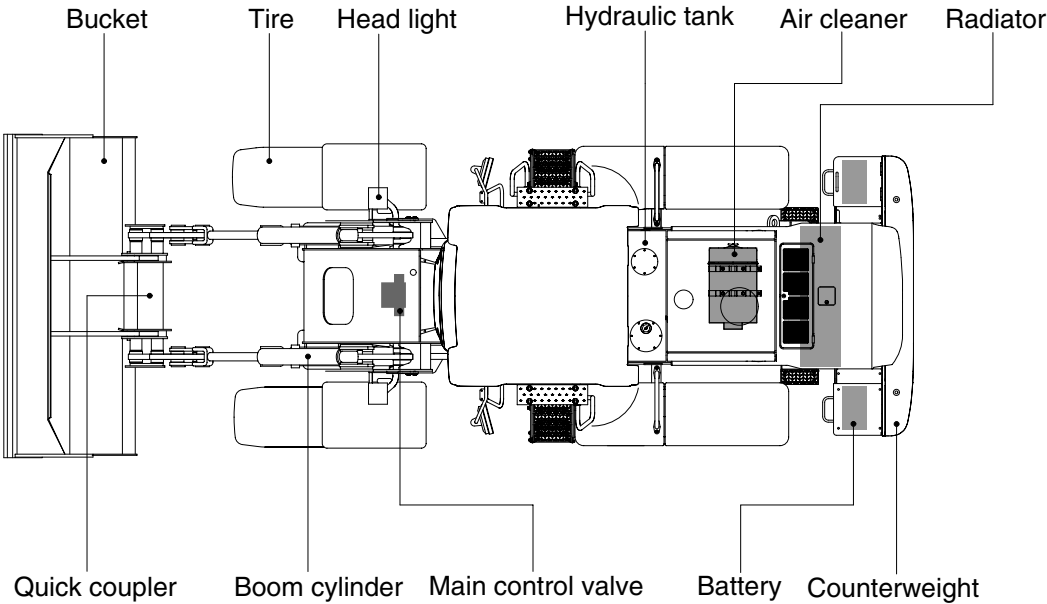

757TM92SE01