

## 8. AIR CONDITIONER AND HEATER

### 1) CLEAN AND REPLACE OF OUTER FILTER

※ Always stop the engine before servicing.

- (1) Open the door, loosen the wing bolt and remove the outer filter.

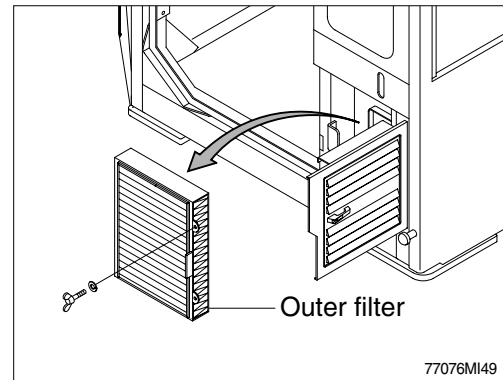

- (2) Clean the filter using a pressurized air (Below  $2\text{kgf/cm}^2$ , 28psi).

△ When using pressurized air, be sure to safety glasses.

- (3) Inspect the filter after cleaning. If it is damaged or badly contaminated, use a new filter.

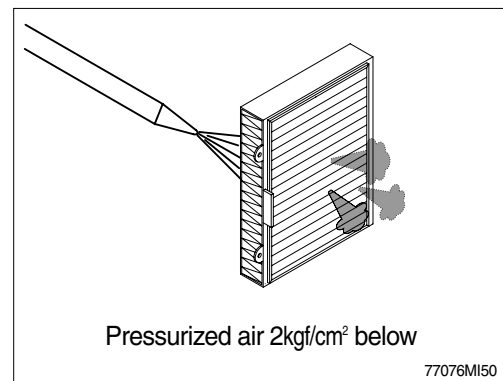

### 2) CLEAN AND REPLACE OF INNER FILTER

※ Always stop the engine before servicing.

- (1) Open the cover.
- (2) Remove the inner filter.

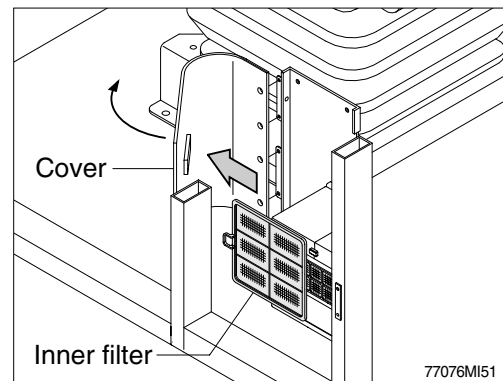

- (3) Clean the inner filter using a pressurized air (Below  $2\text{kgf/cm}^2$ , 28psi) or washing with water.

△ When using pressurized air, be sure to wear safety glasses.

- (4) Inspect the filter after cleaning. If it is damaged or badly contaminated, use a new filter.

※ Dry off after washing with water.

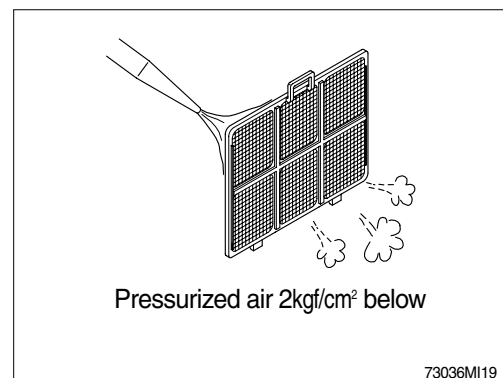

### **3) PRECAUTIONS FOR USING AIR CONDITIONER**

- (1) When using the air conditioner for a long time, open the window once every one hour.
- (2) Be careful not to overcool the cab.
- (3) The cab is properly cooled if the operator feels cool when entering there from outside (About 5°C lower than the outside temperature).
- (4) When cooling, change air occasionally.

### **4) CHECK DURING SEASON**

Ask the service center for replenishment of refrigerant or other maintenance service so that the cooling performance is not damaged.

### **5) CHECK DURING OFF-SEASON**

Operate the air conditioner 2 or 3 times a month (Each for a few minutes) to avoid loss of oil film in the compressor.

