

3. LOADING THE MACHINE

- 1) Load and unload the machine on a flat ground.
- 2) Use the gangplank with sufficient length, width, thickness and gradient.
- 3) Move slowly and carefully when the machine is on the gangplank.
Do not change the direction of the machine while it is on the gangplank.

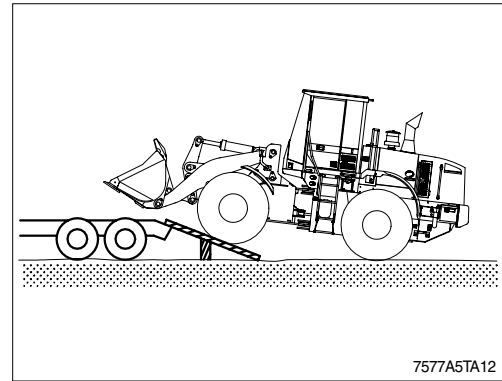

- 4) Do the following after loading the machine to the trailer.
 - (1) Lower the working equipment gently after the location is determined.
 - ※ Place rectangular timber under the bucket cylinder to prevent the damage of it during transportation.
 - ▲ Do not operate any other device when loading.
 - ▲ Balance the load.

