

7. EFFICIENT WORKING METHOD

1) GENERAL

- (1) Lift the bucket about 40-50cm(2ft) above the ground to ensure safety and to gain a good range of view.

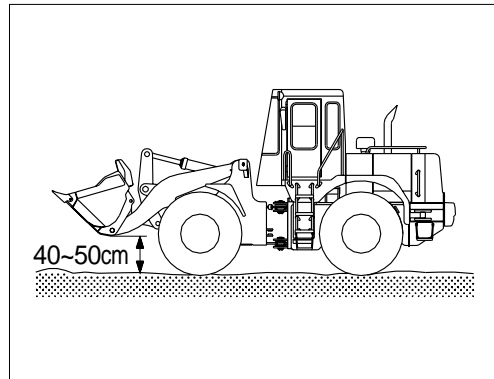

- (2) Clear the jobsite and level the ground.
- (3) Be careful that excessive force is not applied to the bucket.
- (4) When handling hard materials, use bucket teeth or bolt on cutting edge.
- (5) When doing dumping work, put the control lever in the DUMP position, then return it to a former state. Repeat this procedure until the work is finished.
- (6) Position the machine with its back against the wind so that dust does not get into the engine.
- (7) Check if the proper bucket is used for the work.
If the capacity of the bucket exceeds that of the machine, the machine's service life may be shortened.

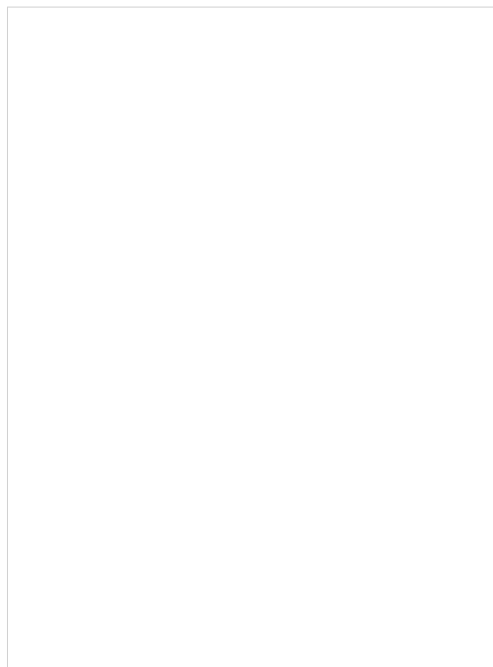

2) EXCAVATION WORK

(1) Shovel work

As the machine loads on the bucket with traveling, tires may start to slip because of heavy load. Then lift the bucket slightly to reduce load.

- Keep the bucket shovel parallel to the ground (If the bucket is pushed in a non-horizontal position, power may be reduced, and the bucket cannot dig deeply into the heap of soil).

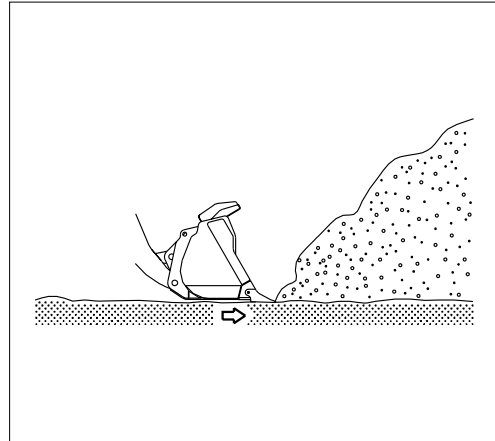

- When the bucket is sufficiently deep into the pile, advance the machine with the control lever pulled down. And by placing the control lever in the bucket roll-back position, fill the bucket with soil.

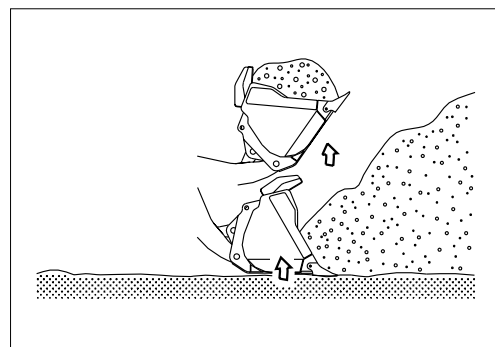

- When it is difficult to dig into the soil, move the bucket control lever forward and backward to move the bucket teeth up and down.

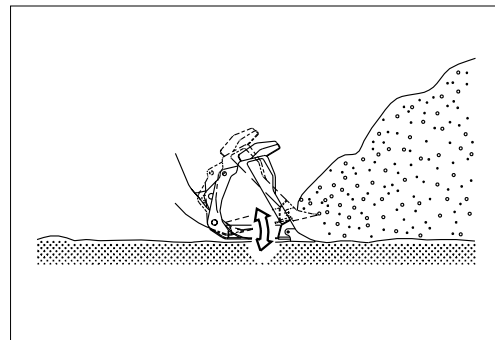

- i If the machine operates with its front tires lifted, its driving force will deteriorate and excessive force will be applied to the rear tires. Avoid operating in that posture.

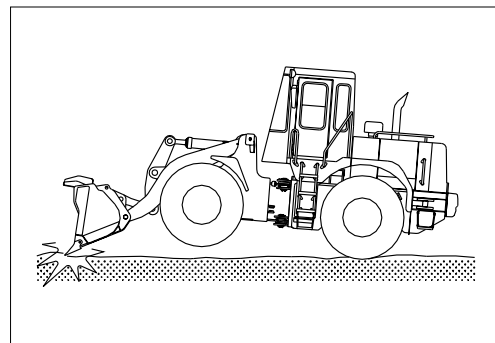

(2) Excavation on level ground

Advance the machine with the bucket lowered slightly and make sure that the bucket is evenly loaded on both sides.

- Lower the bucket edge slightly.

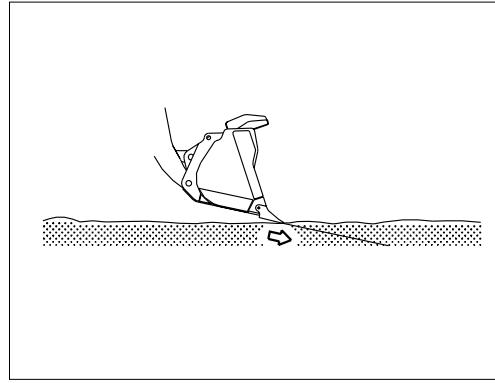

- Advance the machine and lift the bucket using the bucket control lever to dig out the soil.

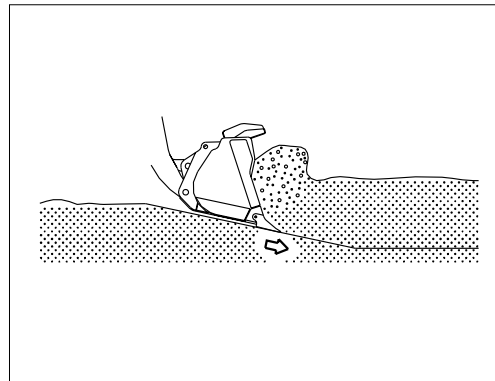

- Advance the machine while controlling the depth of digging with the control lever.

- **Do not press the bucket heavily into the ground. It may damage its driving force.**
- **Use the bucket suitable to the working condition.**
- **When excavating, prevent the excavation force from applying only one side of the bucket.**

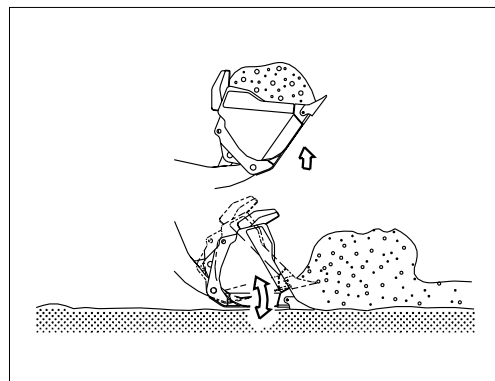

3) LEVELING

- (1) Load the bucket with soil and dump gradually the soil while driving backward.
- (2) After dumping the soil, move backward with the bucket lowered to the ground to level the ground.
- (3) Load the bucket with soil and place the bucket in the horizontal position. Then put the control lever in the BOOM FLOAT position and move backward.
 - i **Make sure that the machine moves always backward when doing leveling work.**

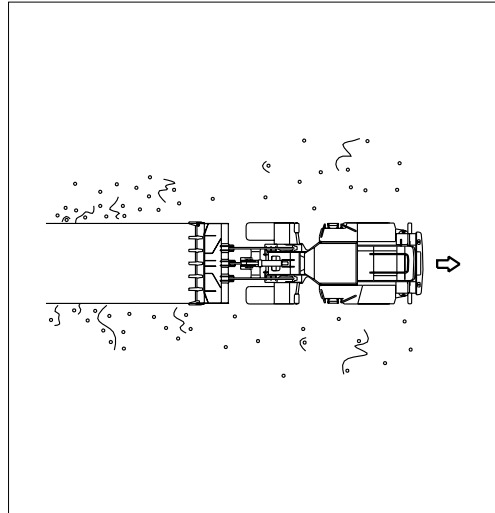

4) TRANSPORTATION

- i **Make sure that the traveling path is always cleared.**
- i **When transporting material, lift the bucket 40-50cm above the ground.**

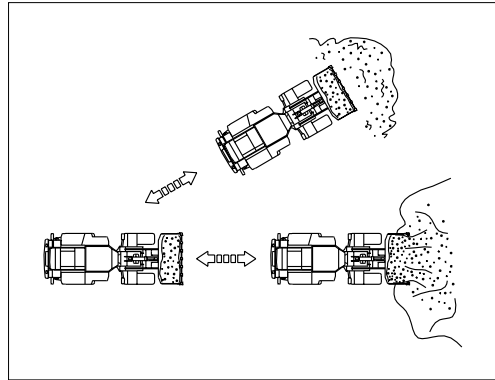

5) COMPACTION

When operating, keep the bottom of the bucket horizontal to the ground.

- i **Do not work with the bucket set in the DUMP position.**

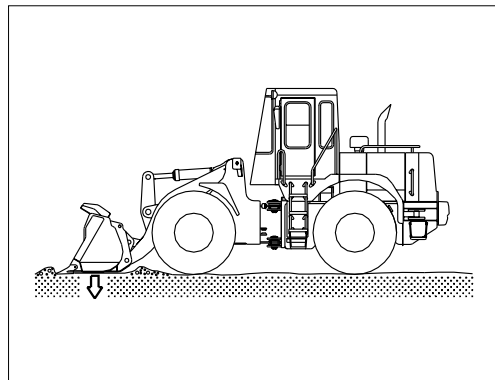

6) LOADING

Maximum efficiency can be attained by carrying out work in such a way that the swinging angle and the traveling distance are kept as small and short as possible in accordance with the terrain.

(1) I method

- After digging out the soil, move backward and position the dump truck between the heap of soil and the machine to load the soil into the truck.
- This is the fastest and most efficient way to load material.
- ⓘ **The ground of the jobsite should be always level and do not swing or step on a brake pedal abruptly with the boom raised.**

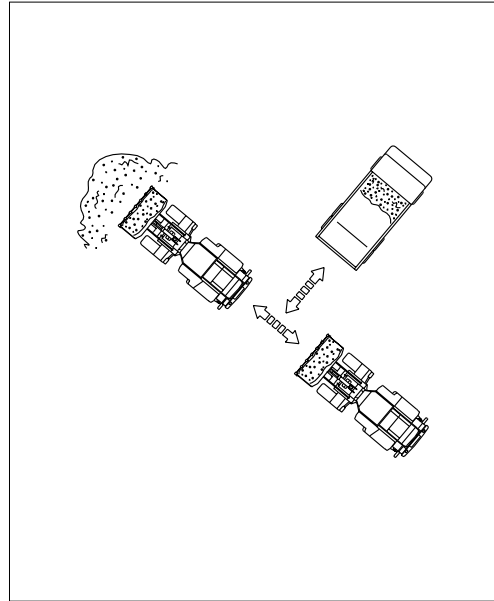

(2) V method

- Park the truck at an angle of 60 degrees toward the machine. After digging out, drive backward and position the machine at a right angle with the truck and load the truck with the soil.
- Position the machine so that the soil can be dumped in the center of the truck. If the length of the truck is more than double the width of the bucket, perform the dumping work from forward to backward.
- Move the control lever to the right and dump the bucket.
- Shake the bucket to throw off the soil stuck inside. Move the bucket control lever to the left and right and attach the bucket to the stopper.
- Shake the bucket before setting it to the DUMP position so that loaded materials are evenly distributed inside the bucket. This will prevent materials from slipping back when the bucket is placed in the DUMP position.

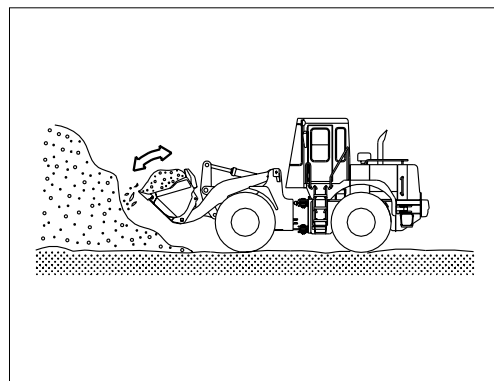
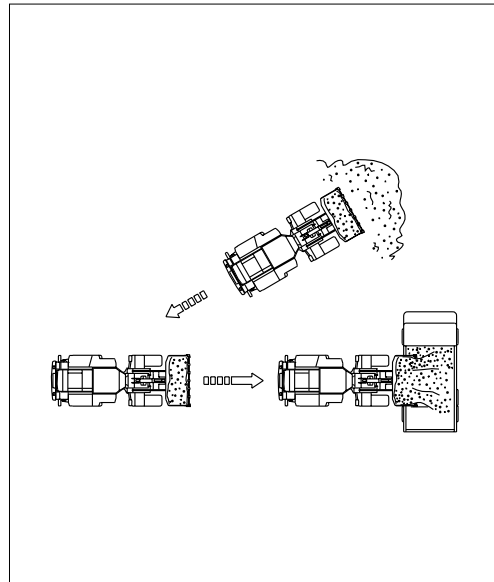

7) PRECAUTIONS DURING OPERATION

(1) Permissible water level

- Do not work in water or damp ground deeper than the permissible depth (Up to lower part of the axle housing).
- After the work is completed, grease parts which has been immersed in water.

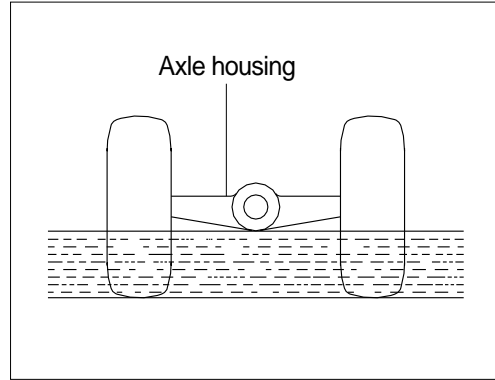

(2) When the brake does not operate

- If the machine does not stop even though the brake pedal is applied, use the parking brake.
- i **After using the parking brake as an emergency brake, ask Hyundai dealer to check complete brake system.**

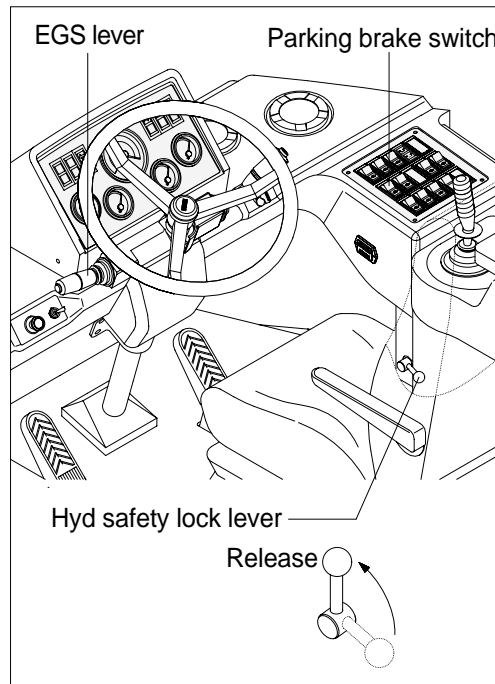

(3) Precautions when driving on a slope

- When turn on a slope, lower the work equipment to lower its center of gravity. Avoid turn on a slope if possible.

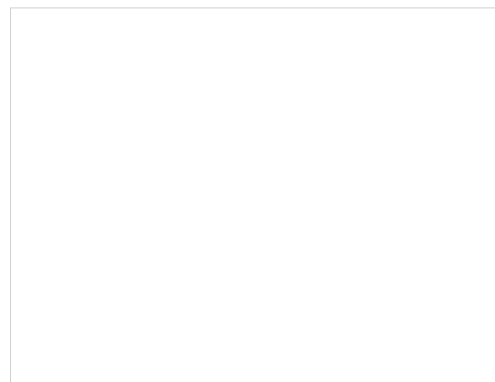

⊠ⓧ **When traveling down a slope**

- a. If the main brake is used too often when traveling down a slope, it may be overheated and damaged. So put the transmission lever in the low speed position and use the engine as a brake.
- b. If there is a mismatch of speed, torque converter oil temperature may be overheated. Set the speed in 1st speed position to allow the temperature to drop.
- c. When the gauge does not move into the green range at the 1st speed, stop the machine and put it in neutral. Run the engine at a mid range speed until the gauge moves into the green range.

⊠∅ **When the engine stops**

If the engine stops on a slope, press the parking brake switch immediately and lower the work equipment to stop the machine.

(4) Precautions when traveling

Do not travel a long distance at high speed. It may overheat tires and cause premature damage. If it is necessary to travel a long distance at high speed, observe the following.

- ⊠ Comply with the regulations concerning this machine to ensure safety.
- ⊠ⓧ Do the pre-inspection before starting off.
- ⊠∅ As the optimum air pressure of tire and optimum driving speed is different according to the kinds of tires and road conditions, consult **Hyundai dealer or tire distributor**.
- ⊠Ⓢ Check the air pressure of tire before driving.
- ⊠° After 1 hour driving, stop for 30 minutes to check any abnormality of tires and other parts, and level of oil and coolant.
- ⊠ Travel with the bucket empty.

