

## 6. TRAVELING OF THE MACHINE

### 1) BASIC OPERATION

#### (1) Traveling posture

Lift the boom so that the bucket is placed 40-50cm above the ground.

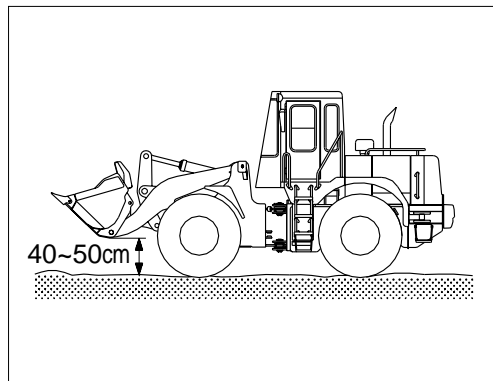

#### (2) Traveling operation

When warm-up operation is completed after the engine is started, move the machine according to the following procedure.

- Release the hydraulic safety lock lever.
- Release the parking brake.
- Put the EGS lever in the 1st stage of forward or backward direction and press gently the accelerator pedal to move the machine.

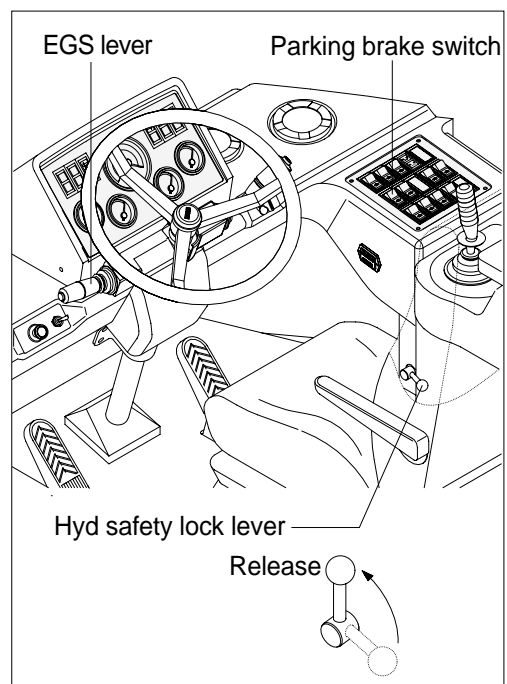

#### (3) Changing speed

- If you want to change the speed, move the EGS lever into the desired position.
- When doing digging or dumping work, run the machine in the 1st or 2nd speed.
- ⓘ **When traveling at high speed, do not abruptly decelerate by using the transmission lever, to slow down instead press the brake pedal.**

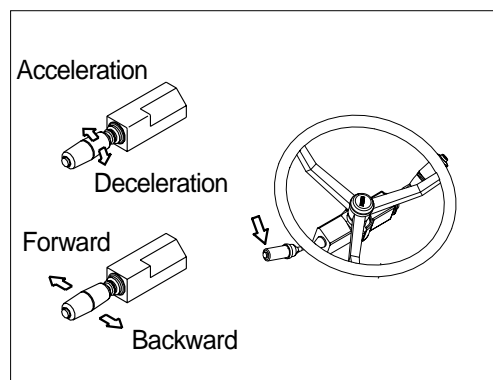

#### (4) Changing direction(Forward/Backward)

- It is possible to change direction (Forward /Backward) without stopping the machine.
- ⌚ Put the lever in the desired position to change direction.
- ¡ **When changing direction, check beforehand there is no obstacle in the direction you will be headed.**
- ¡ **Avoid changing direction at high speed.**

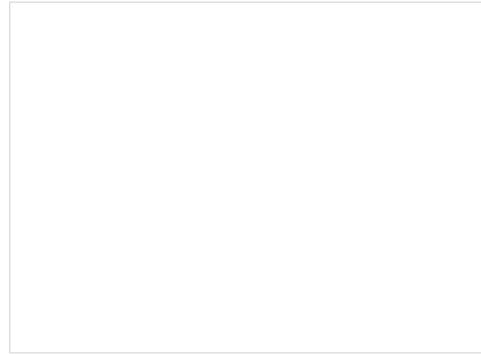

#### (5) Turning the machine

- Turn the machine by moving the steering wheel into the desired direction.
- ⌚ You can turn the machine to the left or right by 40 degree.
- ¡ **Do not turn the machine abruptly when traveling at high speed and avoid turn on a slope.**
- ▲ **Steering does not function with engine OFF.**

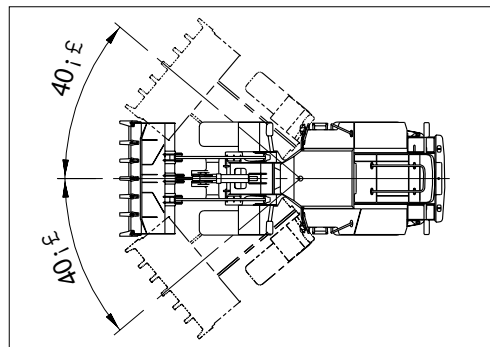

#### (6) Precautions when driving

- If the monitor warning lamp lights up, put the EGS lever in the neutral position and stop the machine. Stop the engine after running it at low idling. Then resolve any problems regarding operation of the machine.
- ⌚ When operating the machine, if the load is lighten rapidly, the speed of the machine will increase. So, be careful.
- ∅ When the machine travels on uneven ground, keep the machine traveling at low speed.

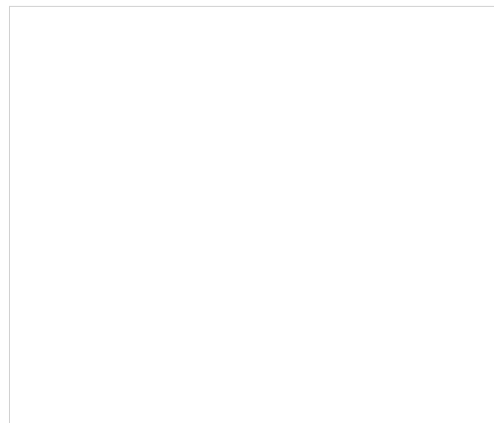

## (7) Stopping the machine

- Press the brake pedal to stop the machine.
- $\perp$  Put the EGS lever in the neutral position.
- $\emptyset$  Press the parking brake switch.

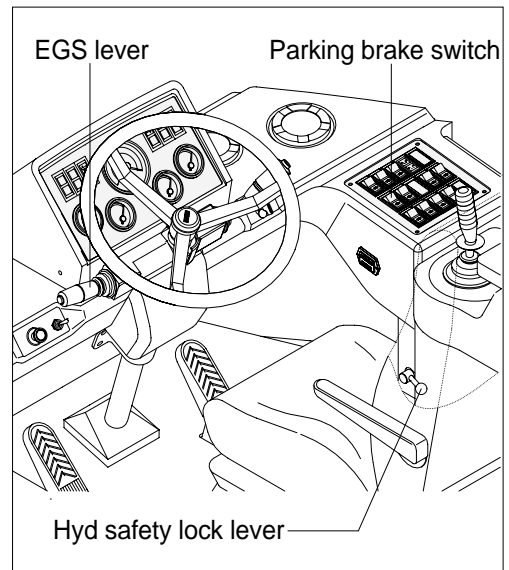

- $\perp$  Lower the bucket to the ground.

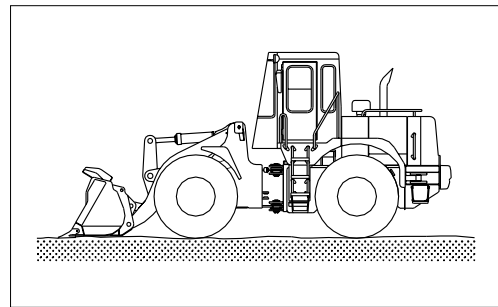

- $\circ$  Put the hydraulic safety lock lever in the lock position.
- i **When parking on a slope, block the tires.**

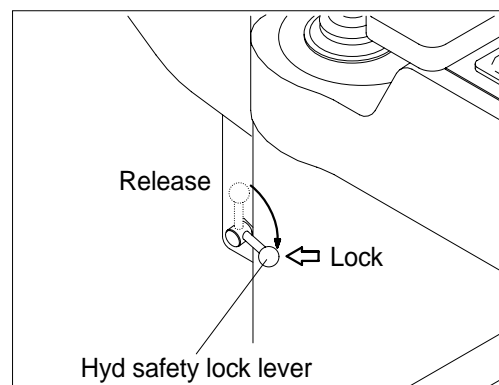

### (8) Stopping engine

- i If the engine is abruptly stopped before it has cooled down, its service life may be shortened. Avoid sudden stop except an emergency.
- i When the engine is overheated, do not stop immediately. Run the engine at a mid range speed to allow it to cool down, then stop it.
  - ⊠ Check if the parking brake is in the lock position.
  - ⊠ Check if the EGS lever is in the neutral position.
  - ⊠ Check if the hydraulic safety lock lever is in the LOCK position.
  - ⊠ Run the engine at low speed without operating the equipment for about 5 minutes. Turn the starting key to the OFF position and remove the key.

### (9) Checks after the engine stopped

- ⊠ Check the leakage of oil and water, the work equipment and the exterior of the machine.
- ⊠ Refill the fuel tank.
- ⊠ Remove any debris inside of the engine room and attached to the machine.

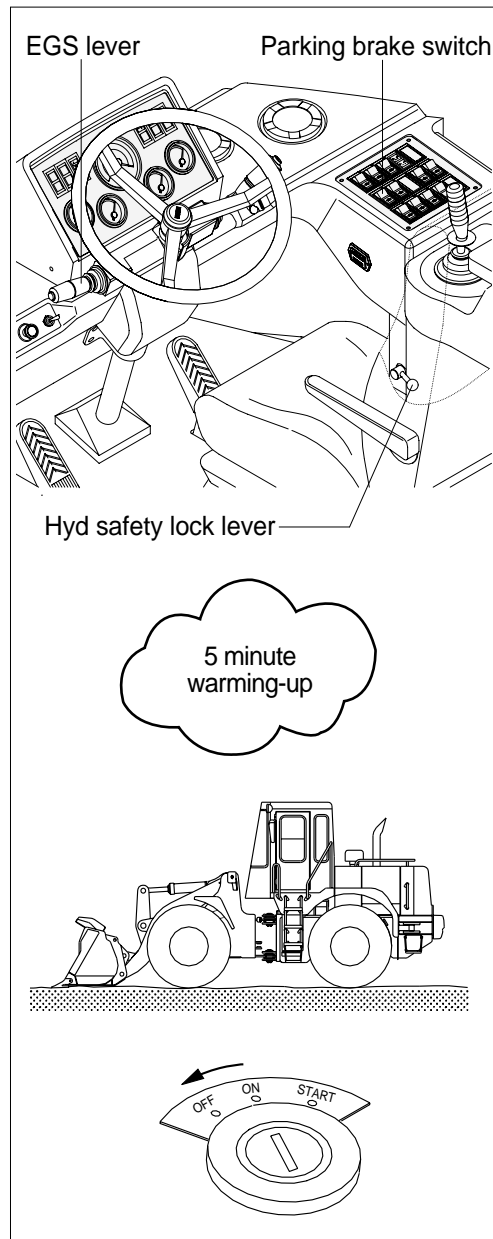

## 2) TRAVELING ON A SLOPE

- (1) Never travel down a slope in neutral.
- (2) Lower the bucket 20-30cm(1ft) to the ground so that it can be used as a brake in an emergency.
- (3) If the machine starts to slide or loses stability, lower the bucket immediately and brake the machine.
- (4) When parking on a slope, use the bucket as a brake and place blocks behind the tires to prevent sliding.
  - ; **Machine cannot travel effectively on a slope when the oil temperature is low. Do the warming-up operation when it is going to travel on a slope.**
  - ; **Be careful when working on slopes. It may cause the machine to lose its balance and turn over.**

