

# 2. SPECIFICATIONS

## 1. MAJOR COMPONENTS

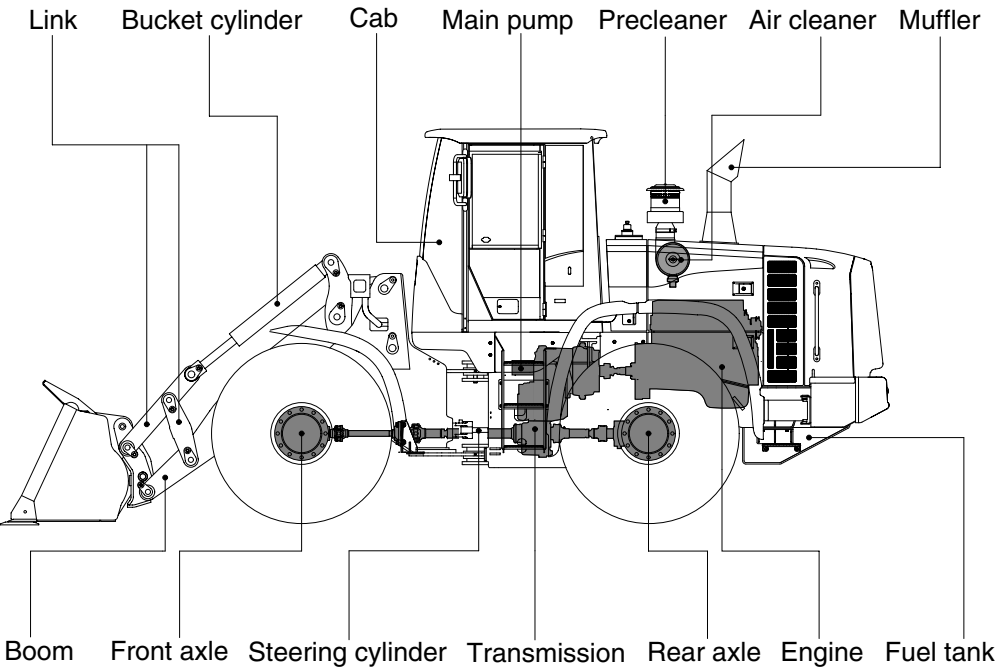
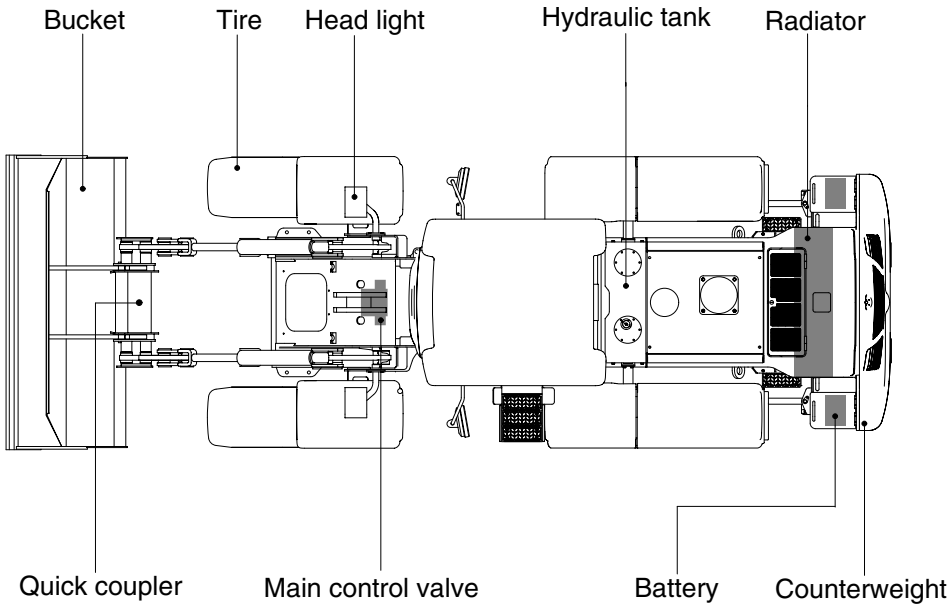

740TM92SP05