

## 2. SPECIFICATIONS

### WITH BOLT-ON CUTTING EDGE TYPE BUCKET

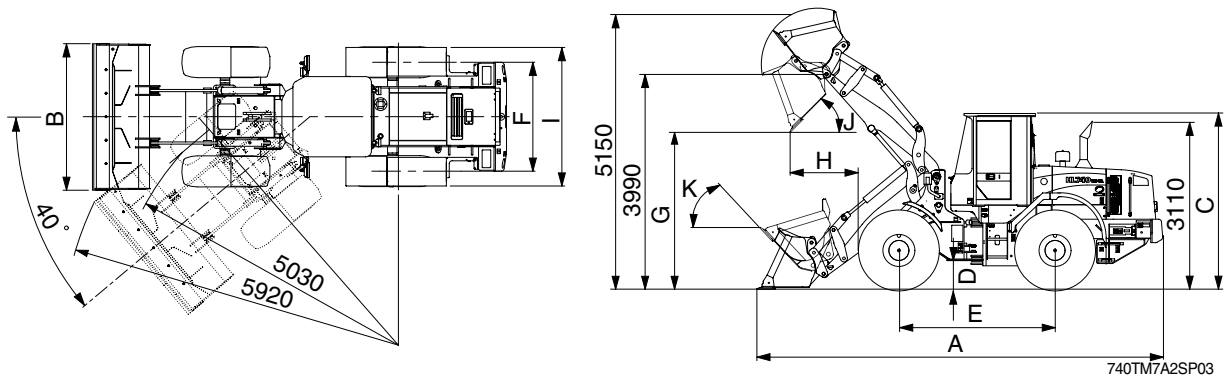

Description		Unit	Specification
Operating weight		kg(lb)	12100(26700)
Bucket capacity	Struck	m <sup>3</sup> (yd <sup>3</sup> )	1.7(2.2)
	Heaped		2.0(2.6)
Overall length	A	mm(ft-in)	7550(24' 9")
Overall width	B		2550( 8' 4")
Overall height	C		3260(10' 8")
Ground clearance	D		417( 1' 4")
Wheelbase	E		2900( 9' 6")
Tread	F		1900( 6' 3")
Dump clearance at 45°	G		2915( 9' 7")
Dump reach(Full lift)	H		1275( 4' 2")
Width over tires	I		2430( 8' 0")
Dump angle	J		Degree (°)
Roll back angle(Carry position)	K	54	
Cycle time	Lift(With load)	sec	5.5
	Dump(With load)		1.4
	Lower(Empty)		2.7
Maximum travel speed		km/hr(mph)	36.3(22.7)
Braking distance		m(ft-in)	12(39' 4")
Minimum turning radius(Center of outside tire)			5.03(16' 6")
Gradability		Degree (°)	30
Travel speed	Forward	First gear	6.4(4.0)
		Second gear	11.7(7.3)
		Third gear	22.3(13.9)
	Reverse	Fourth gear	36.3(22.7)
		First gear	6.8(4.2)
		Second gear	12.4(7.7)
	Third gear	23.4(14.6)	