

8. AIR CONDITIONER AND HEATER

1) CLEAN AND REPLACE OF OUTER FILTER

Always stop the engine before servicing.

- (1) Open the door, loosen the wing bolt and remove the outer filter.

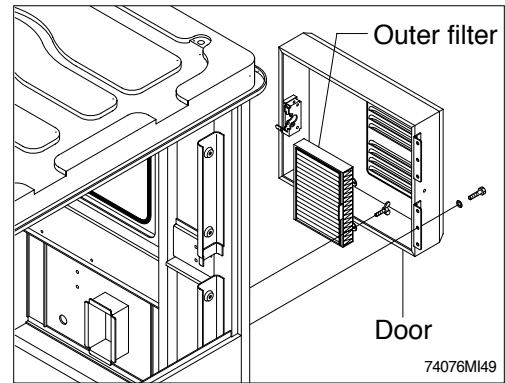

- (2) Clean the filter using a pressurized air (Below 2kgf/cm^2 , 28psi).

△ **When using pressurized air, be sure to safety glasses.**

- (3) Inspect the filter after cleaning. If it is damaged or badly contaminated, use a new filter.

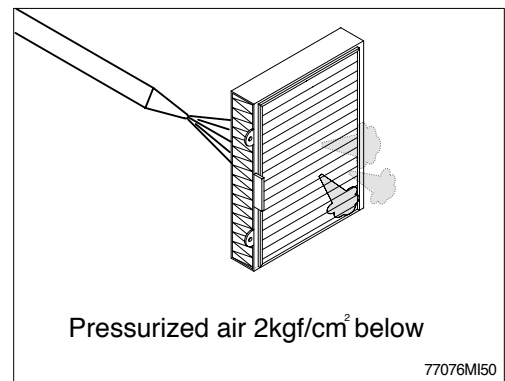

2) CLEAN AND REPLACE OF INNER FILTER

Always stop the engine before servicing.

- (1) Open the cover.
- (2) Remove the inner filter.

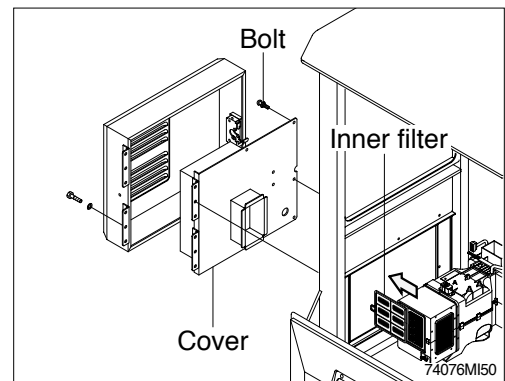

- (3) Clean the inner filter using a pressurized air (Below 2kgf/cm^2 , 28psi) or washing with water.

△ **When using pressurized air, be sure to wear safety glasses.**

- (4) Inspect the filter after cleaning. If it is damaged or badly contaminated, use a new filter.

Dry off after washing with water.

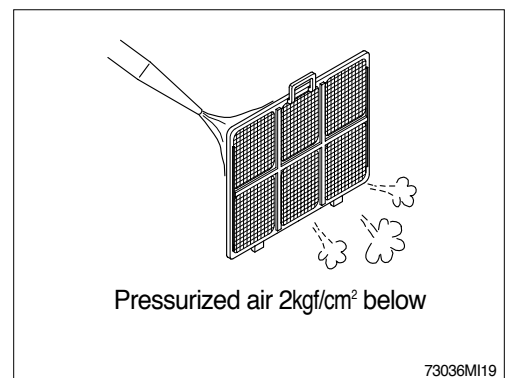

3) PRECAUTIONS FOR USING AIR CONDITIONER

- (1) When using the air conditioner for a long time, open the window once every one hour.
- (2) Be careful not to overcool the cab.
- (3) The cab is properly cooled if the operator feels cool when entering there from outside (About 5°C lower than the outside temperature).
- (4) When cooling, change air occasionally.

4) CHECK DURING SEASON

Ask the service center for replenishment of refrigerant or other maintenance service so that the cooling performance is not damaged.

5) CHECK DURING OFF-SEASON

Operate the air conditioner 2 or 3 times a month (Each for a few minutes) to avoid loss of oil film in the compressor.

