

## 10. STORAGE

Maintain the machine taking care of following to prevent the deterioration of machine when storing the machine for a long time, over 1 month.

### 1) CLEANING THE MACHINE

Clean the machine.

Grease each lubrication part.

### 2) LUBRICATION POSITION OF EACH PART

Change all oil.

※ **Be particularly careful when you reuse the machine.**

**As oil can be diluted during storage.**

**Apply an anticorrosive lubricant on the exposed part of piston rod of cylinder and in places where the machine rusts easily.**

### 3) MASTER SWITCH

Turn OFF the master switch and store the machine.

4) Be sure to mix anticorrosive antifreezing solution in the radiator.

### 5) PREVENTION OF DUST AND MOISTURE

Keep machine dry. Store the machine setting wood on the ground.

※ **Cover exposed part of piston rod of cylinder.**

※ **Lower the bucket to the ground and set a support under tires.**

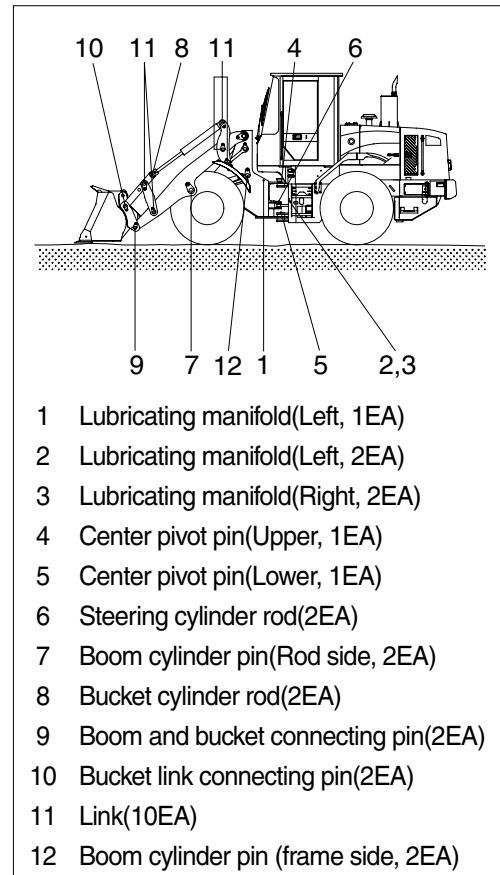

730TM7A4OP37

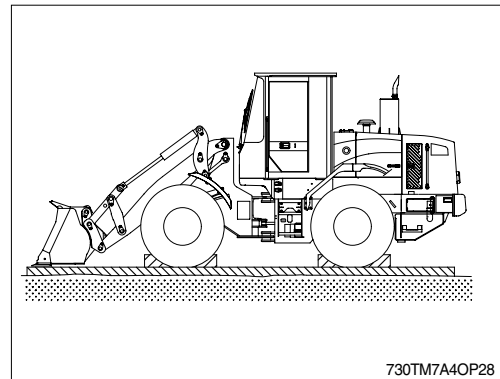

## 6) DURING STORAGE

Start engine and move the machine and working equipment once a month and apply lubrication to each part.

- ※ Check the level of engine oil and coolant and fill if required when starting engine.
- ※ Clean the anticorrosive on the piston rod of cylinder.
- ※ Operate the machine such as traveling, turning, and work equipment operation to make sure enough lubrication of all functional components.

