

6. SERVICE INSTRUCTION

1) CHECK ENGINE OIL LEVEL

Check the oil level with the machine on a flat ground before starting engine.

- (1) Pull out the dipstick and wipe with a clean cloth.
 - (2) Check the oil level by inserting the dipstick completely into the hole and pulling out again.
 - (3) If oil level is LOW, add oil and then check again.
- ※ **If the oil is contaminated or diluted, change the oil regardless of the regular change interval.**
 - ※ **Check oil level after engine has been stopped for 15 minutes.**
 - ▲ **Do not operate unless the oil level is in the normal range.**

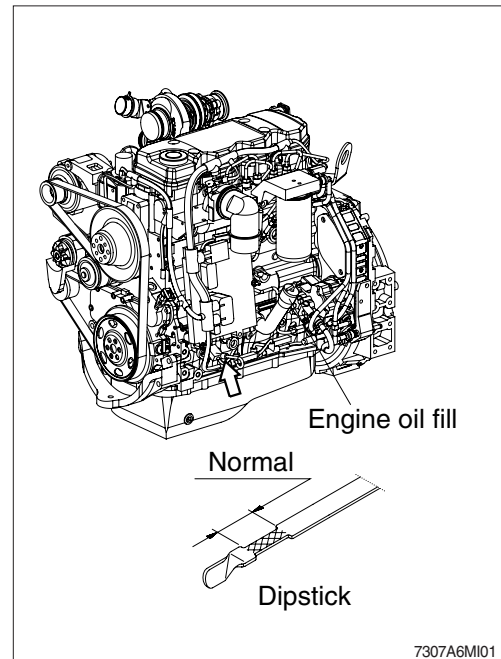

2) REPLACEMENT OF ENGINE OIL AND OIL FILTER

- (1) Operate the engine until the coolant temperature reaches 60°C (140°F). Shut off the engine.
 - (2) Turn the stopper to the open position and allow the oil to drain.
 - Wrench size : 10 mm
- ※ **A drain pan with a capacity of 15 liters (4.0 U.S.gallons) will be adequate.**

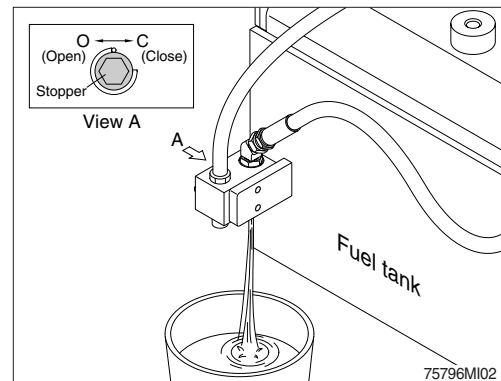

- (3) Clean the area around the oil filter head.
 - (4) Use oil filter wrench to remove the oil filter.
 - (5) Clean the gasket surface of oil filter head.
- ※ **The O-ring can stick on the filter head; make sure it is removed.**

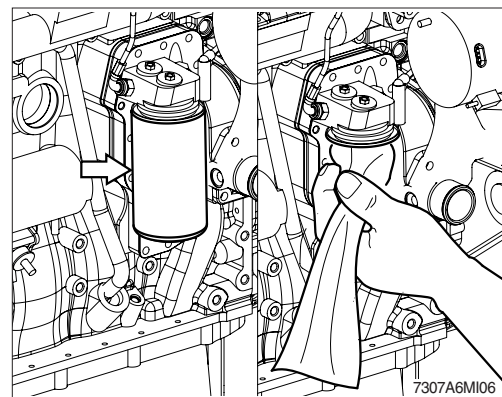

(6) Apply a light film of lubricating oil to the gasket sealing surface before installing the filter.

※ **Fill the filter with clean lubricating oil.**

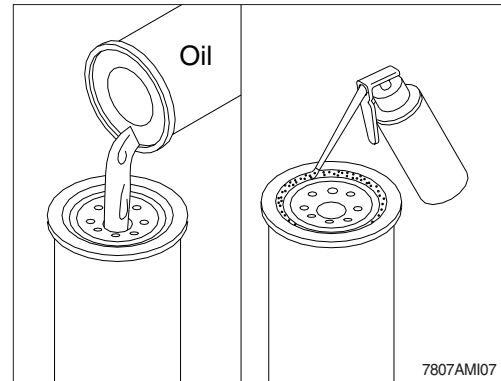

(7) Install the filler to the filter head.

Tighten the filter until the gasket contacts the filter head surface.

※ **Mechanical over-tightening may distort the threads or damage the filter element seal.**

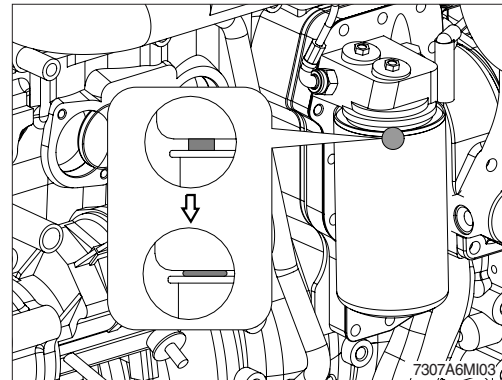

(8) Turn the stopper to the close position.

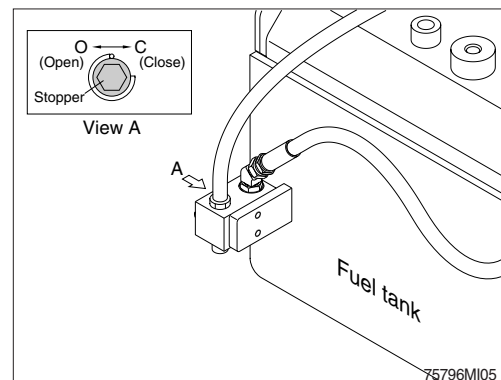

(9) Fill the engine with clean oil to the proper level.

· Quantity : 11 l (2.9 U.S.gallons)

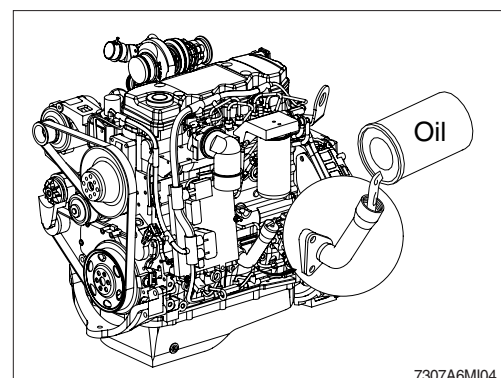

- (10) Operate the engine at low idle and inspect for leaks at the filter and the drain plug.
Shut the engine off and check oil level with dipstick. Allow 15 minutes for oil to drain down before checking.

※ **Do not overfill the engine with oil.**

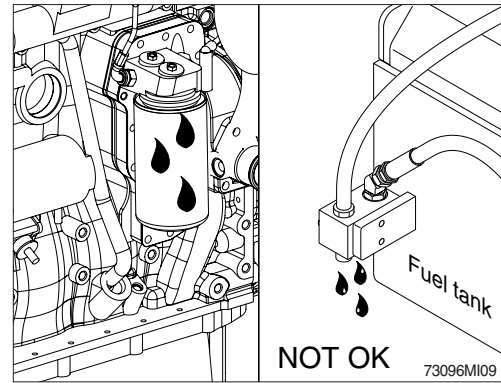

3) CHECK COOLANT LEVEL

- (1) Check the coolant level at the sight gauge.
- (2) Add the mixture of antifreeze and water if coolant is not sufficient.
- (3) The sight gauge should indicate the middle position.
- (4) Replace gasket of radiator cap when it is damaged.

▲ **Do not remove the radiator cap from a hot engine. Wait until the coolant temperature is below 50°C (120°F) before removing the radiator cap. Heated coolant spray or steam can cause personal injury.**

※ **Do not add cold coolant to a hot engine ; engine castings can be damaged. Allow the engine to cool to below 50°C (120°F) before adding coolant.**

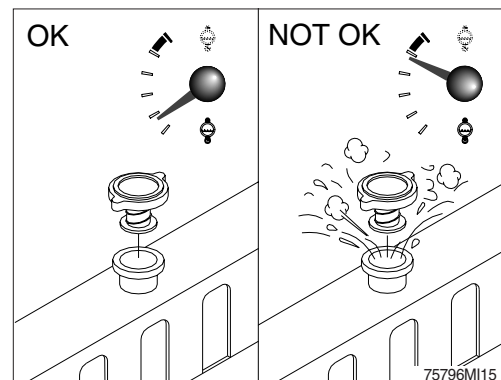
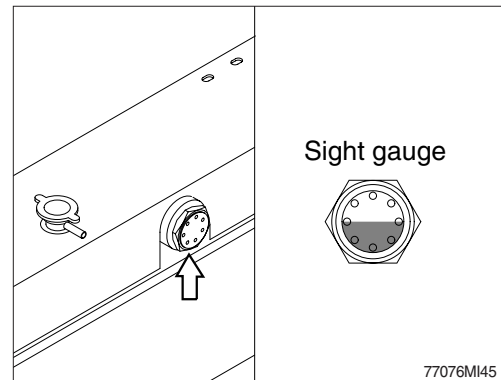

4) FLUSHING AND REFILLING OF RADIATOR

(1) Change coolant

⚠ Avoid prolonged and repeated skin contact with used antifreeze. Such prolonged repeated contact can cause skin disorders or other bodily injury.

Avoid excessive contact-wash thoroughly after contact.

Keep out of reach of children.

⚠ Protect the environment : Handling and disposal of used antifreeze can be subject to federal, state, and local law regulation.

Use authorized waste disposal facilities, including civic amenity sites and garages providing authorized facilities for the receipt of used antifreeze.

If in doubt, contact your local authorities for guidance as to proper handling of used antifreeze.

⚠ Wait until the temperature is below 50°C (120°F) before removing the coolant system radiator cap. Failure to do so can cause personal injury from heated coolant spray.

Drain the cooling system by turning the stopper to the open position.

A drain pan with a capacity of 35 liters (9.2 U.S.gallons) will be adequate in most applications.

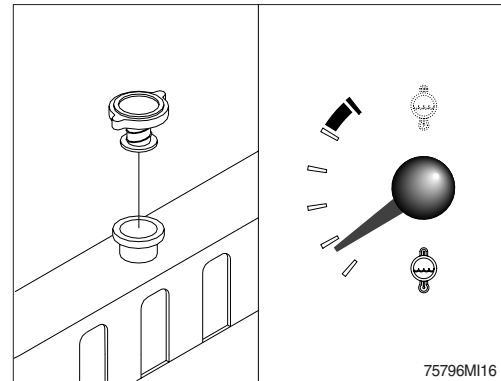

(2) Flushing of cooling system

① Fill the system with a mixture of sodium carbonate and water (or a commercially available equivalent).

※ Use 0.5 kg (1.0 pound) of sodium carbonate for every 23 liters (6.0 U.S. gallons) of water.

※ Do not install the radiator cap. The engine is to be operated without the cap for this process.

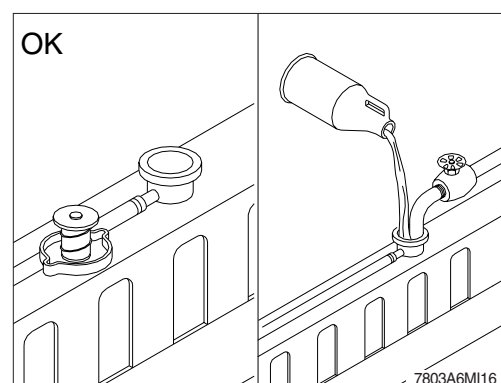
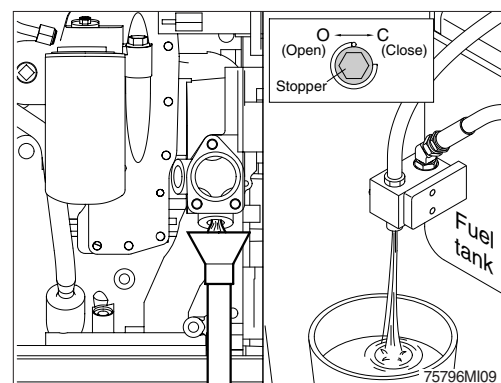

- ② Operate the engine for 5 minutes with the coolant temperature above 80°C (176°F). Shut the engine off, and drain the cooling system.

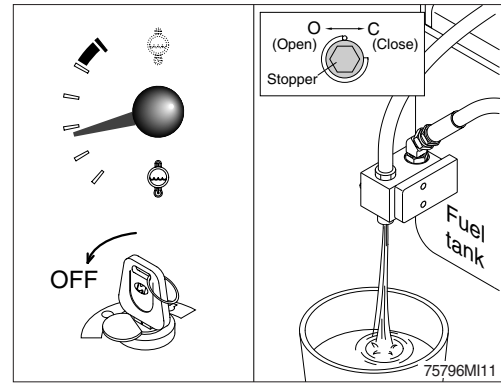

- ③ Fill the cooling system with clean water.
- ※ Be sure to vent the engine and aftercooler for complete filling.
 - ※ Do not install the radiator cap or the new coolant filter.

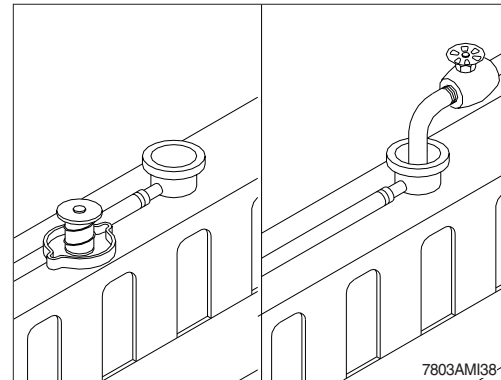

- ④ Operate the engine for 5 minutes with the coolant temperature above 80°C (176°F). Shut the engine off, and drain the cooling system.
- ※ If the water being drained is still dirty, the system must be flushed again until the water is clean.

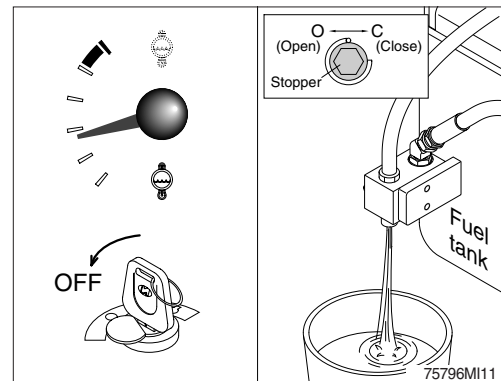

(3) Cooling system filling

- ① Use a mixture of 50 percent water and 50 percent ethylene glycol antifreeze to fill the cooling system.
- ※ Use the correct amount of DCA4 corrosion inhibitor to protect the cooling system.
 - ※ Never use water alone for coolant. This can result in damage from corrosion.

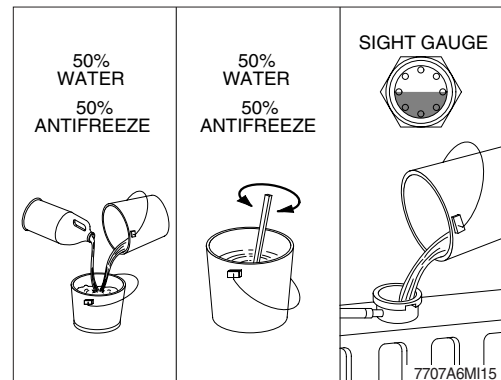

- ② Install the radiator cap. Operate the engine until it reaches a temperature 80°C (176°F), and check for coolant leaks. Check the coolant level again to make sure the system is full of coolant.

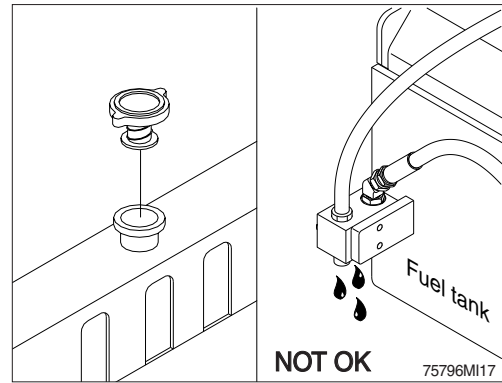

5) CLEAN RADIATOR AND OIL COOLER

Check, and if necessary, clean and dry outside of radiator and oil cooler. After working in a dusty place, clean radiator more frequently.

- (1) Visually inspect the radiator for clogged radiator fins.
- (2) Use 550 kPa (80 psi) air pressure to blow the dirt and debris from the fins.
Blow the air in the opposite direction of the fan air flow.
- (3) Visually inspect the radiator for bent or broken fins.
※ If the radiator must be replaced due to bent or broken fins which can cause the engine to overheat, refer to the manufacturer's replacement procedures.
- (4) Visually inspect the radiator for core and gasket leaks.

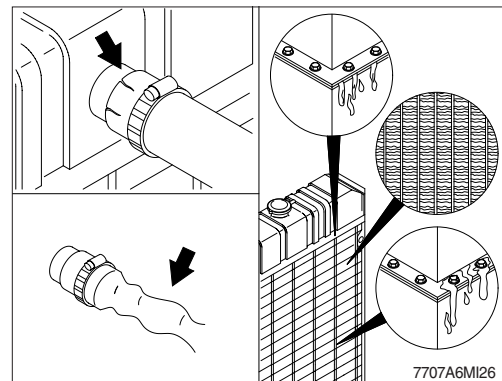
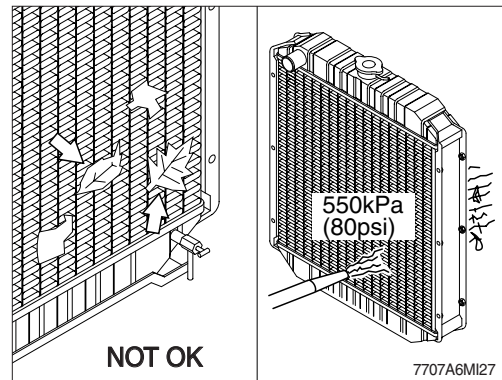

6) CHECK CHARGE AIR COOLER

- (1) Inspect the charge air cooler for dirt and debris blocking the fins. Check for cracks, holes, or other damage. If damage is found, please contact hyundai distributor.

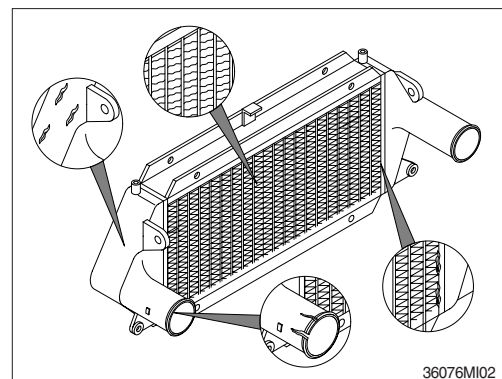

7) DRIVE BELT

- (1) Inspect the belts daily. Check the belts for intersecting cracks. Transverse (across the belt width) cracks are acceptable. Longitudinal (direction of belt length) cracks that intersect the transverse cracks are not acceptable. Replace a belt if it is frayed or has pieces of material missing.

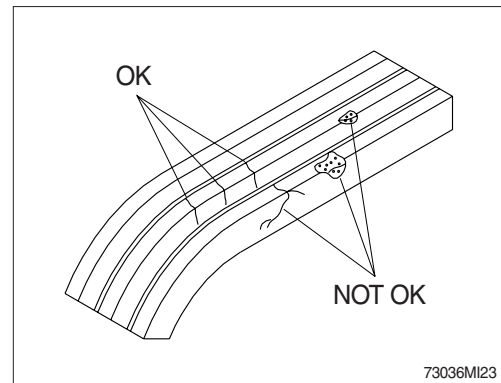

8) INSPECTION OF COOLING FAN

- ⚠ Personal injury can result from a fan blade failure. Never pull or pry on the fan. This can damage the fan blade and cause fan failure.**
- ※ Rotate the crankshaft by using the engine barring gear.
 - ※ A visual inspection of the cooling fan is required daily.
- Check for cracks, loose rivets, and bent or loose blades.
- Check the fan to make sure it is securely mounted. Tighten the capscrews if necessary.
- Replace any fan that is damaged.

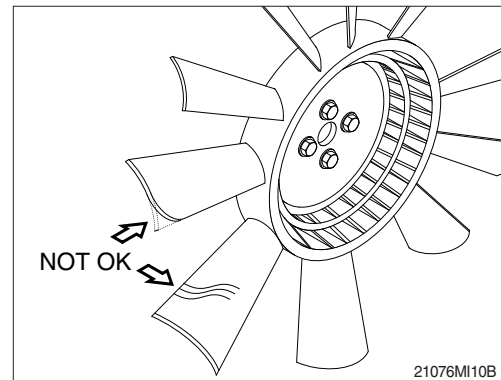

9) BELT TENSIONER, AUTOMATIC ADJUSTMENT

- (1) Every 1000 hours, or 1 year, whichever occurs first, inspect the automatic belt tensioner.
- With the engine turned off, check that neither the top nor bottom tensioner arm stop is touching the cast boss on the tensioner body. If either of the stops is touching a boss, the alternator belt must be replaced. Check to make sure the correct belt part number is being used if either condition exists.
- (2) Check the tensioner pulley and body for cracks. If any cracks are noticed, the tensioner must be replaced. Refer to a Cummins Authorized Repair facility. Check the tensioner for dirt buildup. If this condition exists, the tensioner must be removed and steam-cleaned.

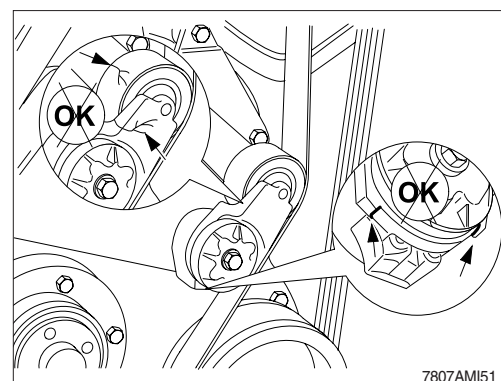
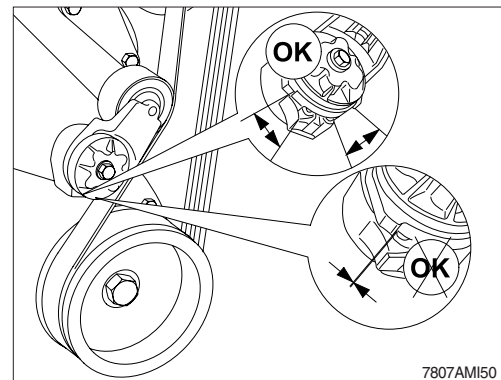

- (3) Check that the bottom tensioner arm stop is in contact with the bottom tensioner arm stop boss on the tensioner body. If these two are not touching, the tensioner must be replaced.

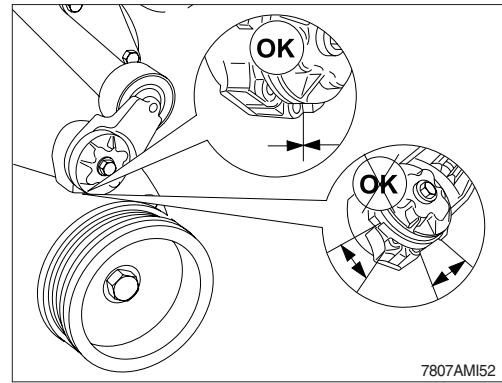

- (4) Inspect the tensioner for evidence of the pivoting tensioner arm contacting the stationary circular base. If there is evidence of these two areas touching, the pivot tube bushing has failed and the tensioner must be replaced.

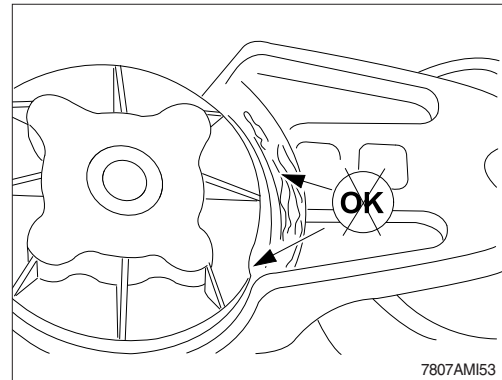

- (5) A worn tensioner that has play in it or a belt that “walks” off its pulley possibly indicates pulley misalignment.

※ **Maximum pulley misalignment is three degrees. This measurement can be taken with a straightedge and an inclinometer.**

- (6) Install the belt.

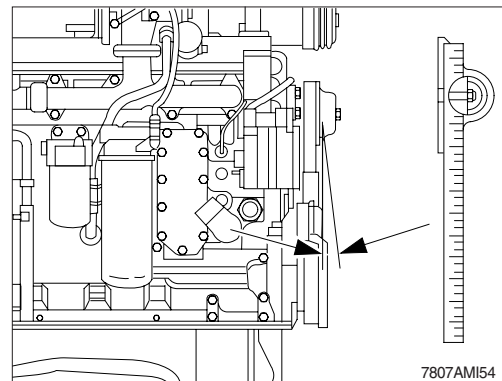

10) CLEANING OF AIR CLEANER

(1) Primary element

- ① Loosen the wing nut and remove the element.
 - ② Clean the inside of the body.
 - ③ Clean the element with pressurized air.
 - Remove the dust inside of the element by the pressurized air (below 3 kgf/cm², 40 psi) forward and backward equally.
 - ④ Inspect for cracks or damage of element by putting a light bulb inside of the element.
 - ⑤ Insert element and tighten wing nut.
- ※ **When the air cleaner warning lamp is ON, clean the primary element.**
 - ※ **The primary element should be replaced if the warning lamp is ON after installation of a clean primary element, or if the exhaust smoke is still black.**
 - ※ **Replace the primary element after 4 times cleanings.**

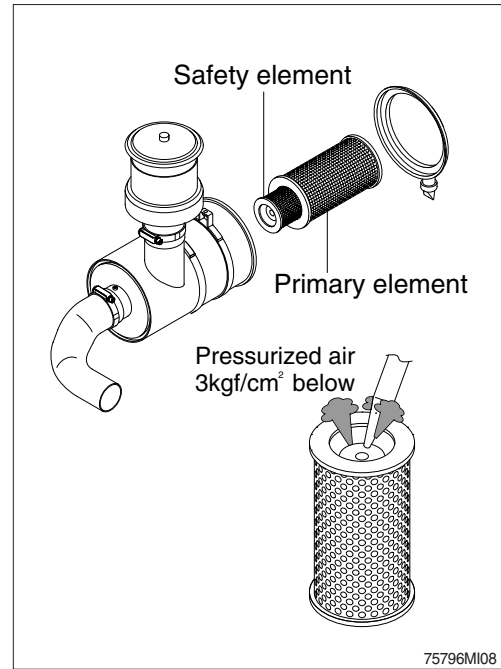

(2) Safety element

- ※ **The safety element should be replaced at the time the primary element is replaced.**
- ※ **Always replace the safety element. Never attempt to reuse the safety element by cleaning the element.**

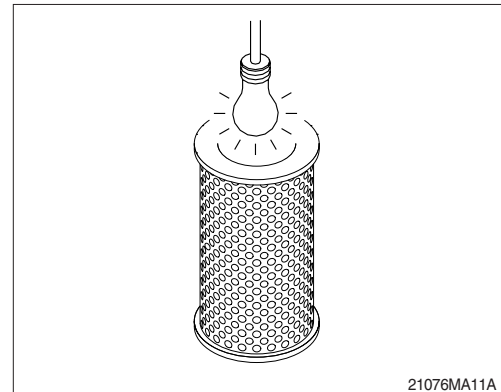

11) FUEL TANK

- (1) Fill fuel fully when system the operation to minimize water condensation, and check it with fuel gauge before starting the machine.
 - (2) Drain the water and sediment in the fuel tank by opening the plug.
- ※ **Be sure to LOCK the cap of fuel tank.**
 - ※ **Remove the strainer of the fuel tank and clean it if contaminated.**
 - ▲ **Stop the engine when refueling.**
All lights and flames shall be kept at a safe distance while refueling.

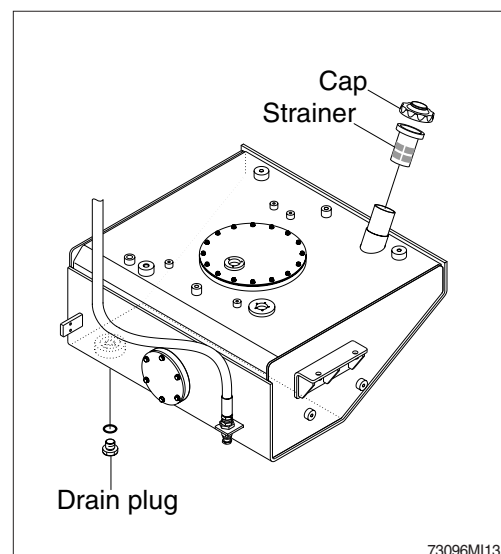

12) REPLACEMENT OF FUEL FILTER

- (1) Clean around the filter head, remove the filter and clean the gasket surface.
 - Wrench size : 90~95 mm (3.5~3.8 in)
- (2) Replace the O-ring.
- (3) Apply engine oil on the gasket of filter when mounting, and tighten 3/4 to 1 turn more after the gasket touches the filter head.
- (4) Relieve the air after mounting.
 - ※ **Do not pre-fill an on-engine fuel filter with fuel. The system must be primed after the fuel filter is installed. Pre filling the fuel filter can result in debris entering the fuel system and damaging fuel system components.**
 - ※ **Check for fuel leakage after the engine starts.**
 - ※ **If air is in the fuel system, the engine will not start. Start engine after bleeding the air according to the method of bleeding air.**

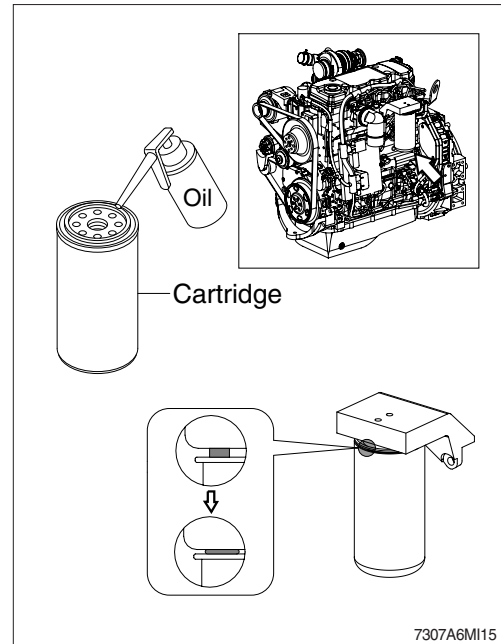

13) PREFILTER

- ※ **Inspect or drain the collection bowl of water daily and replace the element every 500hours.**

(1) Drain water

- ① Open bowl drain valve to evacuate water.
- ② Close drain valve.

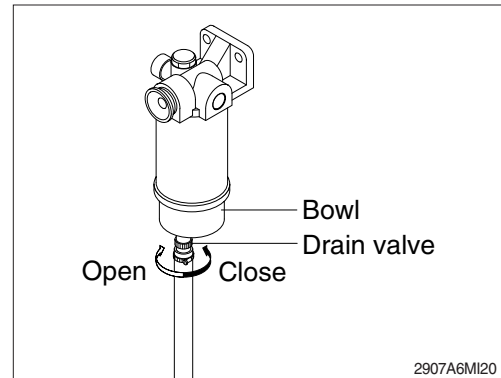

(2) Replace element

- ① Drain the unit of fuel. Follow "Drain water" instructions above.
- ② Remove element, fuel warmer and bowl from filter head.
- ※ **The bowl is reusable, do not damage or discard.**
- ③ Separate element from bowl. Clean bowl and seal gland.

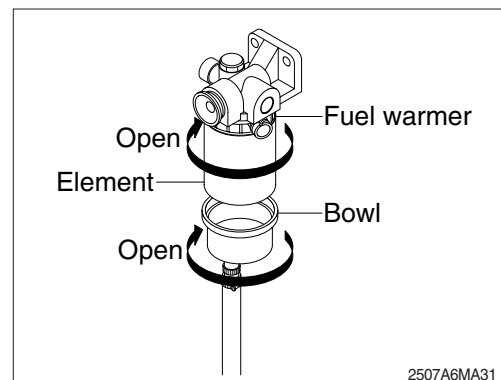

- ④ Lubricate new bowl seal with clean fuel or motor oil and place in bowl gland.
- ⑤ Attach bowl to new element firmly by hand.
- ⑥ Lubricate new element seal and place in element top gland.
- ⑦ Attach the element, fuel warmer and bowl to the head.

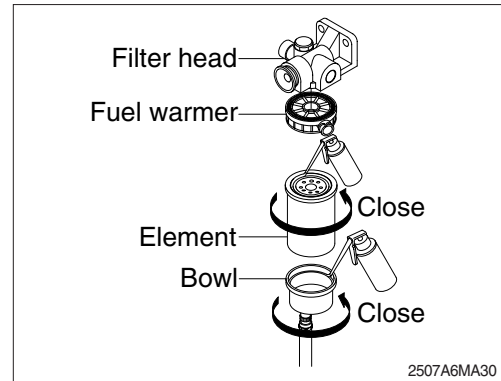

14) BLEEDING THE FUEL SYSTEM

- (1) Loosen fuel supply line plug at the outlet of pre-filter.
- (2) Do hand-priming the lift pump repeatedly until air bubbles comes out from fuel supply line completely.
- (3) Tighten fuel supply line to its origin position.

▲ The fuel pump, high-pressure fuel lines, and fuel rail contain very high-pressure fuel. Do not loosen any fittings while the engine is running. Personal injury and property damage can result. Wait at least 10 minutes after shutting down the engine before loosening any fittings in the high-pressure fuel system to allow pressure to do decrease to a lower level.

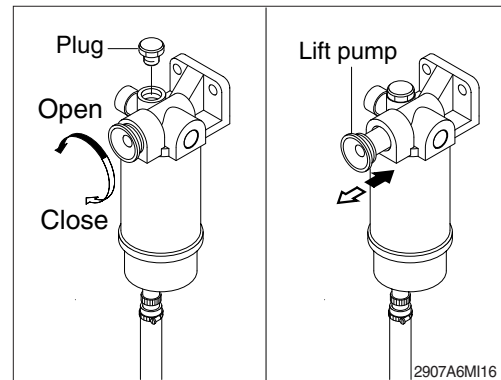

15) LEAKAGE OF FUEL

▲ Be careful and clean the fuel hose, injection pump, fuel filter and other connections as the leakage from these part can cause fire.

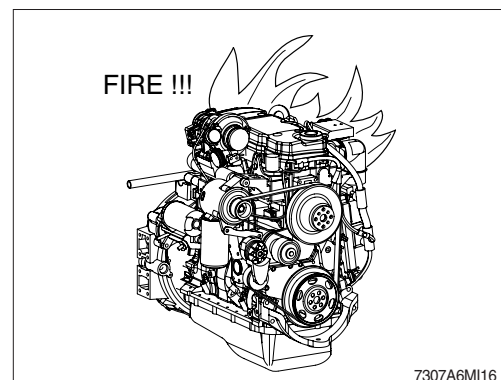

16) HYDRAULIC OIL CHECK

- (1) Lower the bucket on the ground at a flat location as in the illustration.
Stop the engine and then leave for about 5 minutes.
- (2) Check the oil level at the sight gauge. The sight gauge is located on the left side of the hydraulic oil tank.
- (3) The sight gauge should indicate the middle position.

※ **Add hydraulic oil, If necessary.**

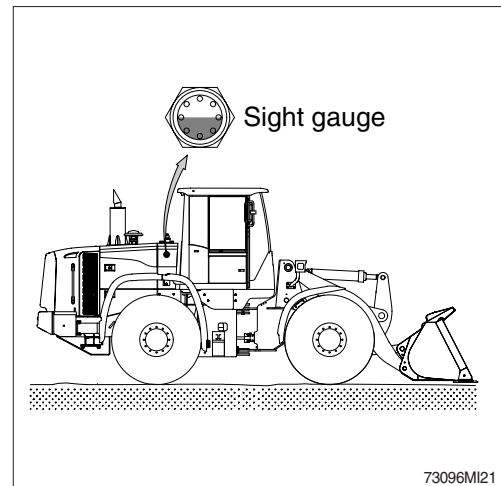

17) FILLING HYDRAULIC OIL

- (1) Stop the engine to the position of level check.
- (2) Rotate the cap nut counter-clockwise by hand and push the rod to release the air pressure.
- (3) Remove the breather on the top of oil tank and fill the oil to the specified level.
- (4) Start engine after filling and operate the work equipment several times.
- (5) Check the oil level at the level check position after engine stops.

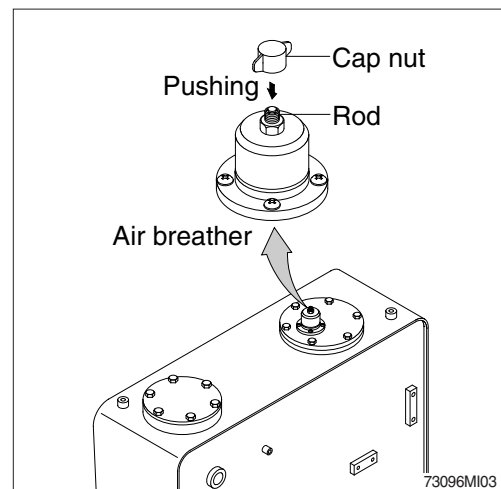

18) CHANGE THE HYDRAULIC OIL

- (1) Lower the bucket on the ground extend the bucket cylinder to the maximum.
- (2) Loosen the cap and relieve the pressure in the tank by pushing the top of the air breather.
- (3) Prepare a suitable container.
- (4) To drain the oil loosen the drain plug at the fuel tank block.
- (5) Tighten the drain plug.
- (6) Fill proper amount of recommended oil.
- (7) Put the breather in the right position.
- (8) Start engine and run continually. Release the air by full stroke of control lever.

※ **The oil must be free of bubbles. If bubbles are present in the oil, air is entering the hydraulic system. Inspect the suction hoses and hose clamps.**

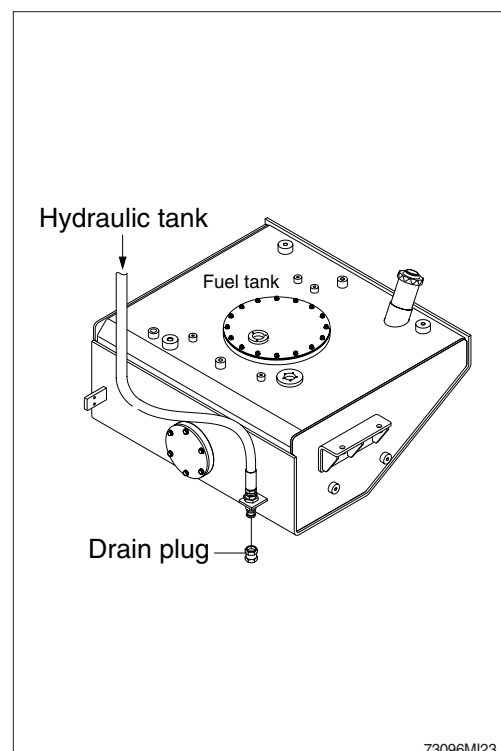

19) CLEANING AND REPLACING RETURN FILTER

Clean and replace the return filter in the following manner.

- (1) Remove the cover.
- (2) Remove spring, by-pass valve and return filter from the tank.
- (3) Replace element with new one and assemble spring and by-pass valve after cleaning.
- (4) Install the cover on the tank.
 - Tightening torque : 6.9 ± 1.4 kgf · m
(50 ± 10 lbf · ft)

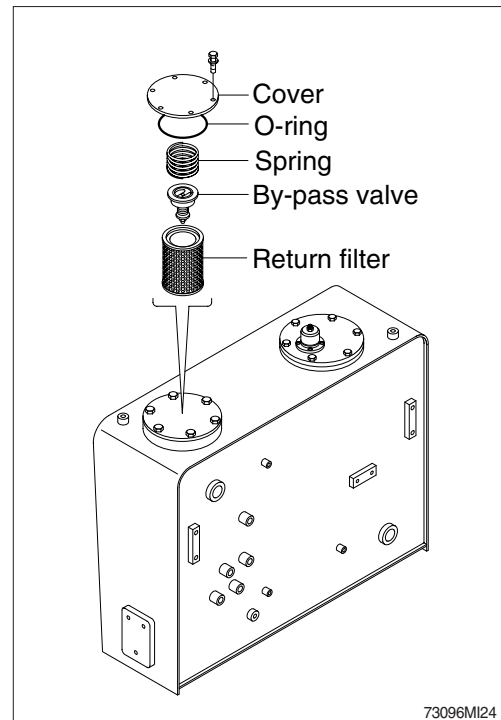

20) REPLACEMENT OF ELEMENT IN HYDRAULIC TANK BREATHER

- (1) Loosen the cap and relieve the pressure in the tank by pushing the top of the air breather.
- (2) Loosen the lock nut and remove the cover.
- (3) Pull out the filter element.
- (4) Replace the filter element new one.
- (5) Reassemble by reverse order of disassembly.
 - Tightening torque : $0.2 \sim 0.3$ kgf · m
($1.4 \sim 2.1$ lbf · ft)

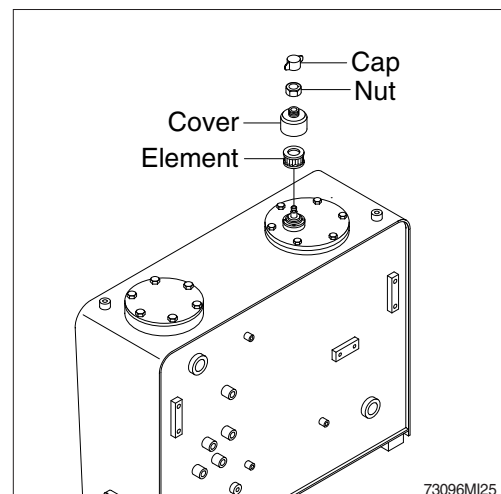

21) REPLACE OF PILOT LINE FILTER

- (1) Loosen the bowl positioned on the safety valve.
- (2) Pull out the filter element and clean the bowl.
- (3) Install the new element and tighten the bowl using spanner.
 - Spanner size : 27 mm

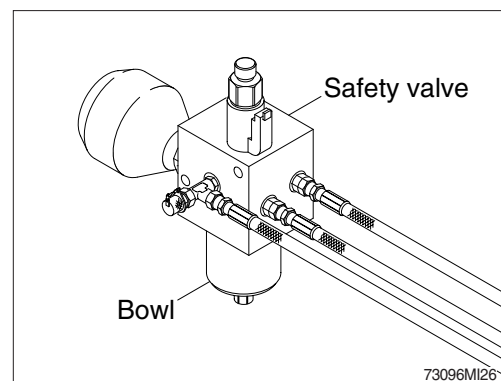

22) REPLACE OF BRAKE PRESSURE FILTER

- (1) Loosen the nut on the filter body.
- (2) Pull out the filter element and clean filter housing.
- (3) Install the new element and tighten the nut using the spanner (36 mm).

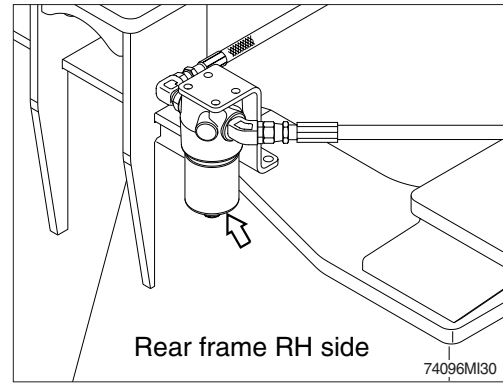

23) LUBRICATE RCV LEVER

Remove bellows and grease the joint (A) and the sliding parts (B).

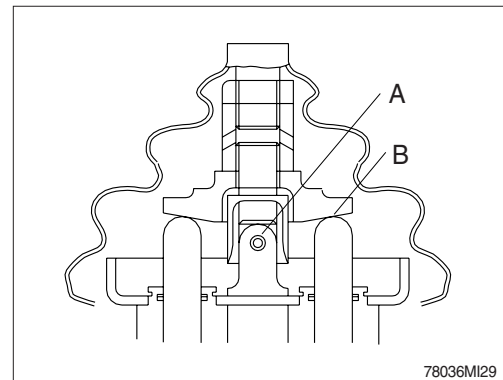

24) TIRE PRESSURE

(1) Inappropriate tire pressure is a primary cause for tire damage. Insufficient tire pressure will damage internal carcass of tire. Repeated excessive bending will damage or break the carcass. Excessive pressure will also cause premature damage of tire.

(2) Recommended tire pressure (When tire is cooled)

Size	Pressure
17.5-25, 12PR (L3)	3.5 bar (50 psi)

(3) Continuous operation will produce heat and increase pressure on tire. But such phenomenon was already taken into account when designing a tire. Do not try to remove normally increased air because tires may be crushed or overinflated.

(4) The three major causes for excessive heat and pressure of tire are insufficient pressure, excessive load and overspeed. Avoid excessive load and overspeed in order to keep tires in good shape.

▲ Do not inflate tires using flammable gases or alcohol injector.

This cause explosion or personal injury.

▲ Inflate tires at the pressure level recommended by the manufacturer, and check periodically pressure and wear of tires.

▲ When replacing the inflated tire, do not stand near the tire.

※ **Check the tire when the tire is at normal temperature and the machine is not loaded.**

▲ Do not use recycled wheel parts.

▲ When removing lockering or inflating tire, use safety cable or chain to ensure safety.

※ **Be sure to bleed air before removing lockering. Never inflate tires unless the lockering is assembled in its place.**

① Avoid the followings when traveling.

② Rubbing tires against road bank or rack at cargo-unloading spot.

③ Tires slippage during working.

④ Abrupt starting of machine.

When oil, grease or gasoline smeared on tire, clean those. Otherwise it may cause of permanent deformation.

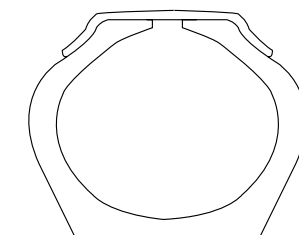
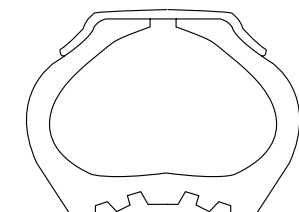
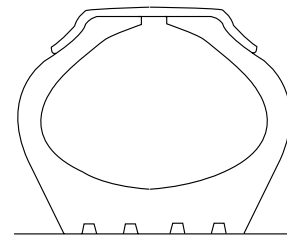

25) REPLACEMENT OF TIRE

▲ Disassembly, reassembly, replacement and repair of tire requires special skills and equipment. Contact a tire repair shop.

(1) Tires to be replaced

- ① Tires with broken or bent bead wires
- ② Tires exposed more than 1/4 of carcass ply.
- ③ Tires whose carcass is damaged more than 1/3 of the tire width.
- ④ Tires which show ply separation.
- ⑤ Tires which has a radial crack near the carcass.
- ⑥ Tires which are judged to be unsuitable for use because of deformation or damage.

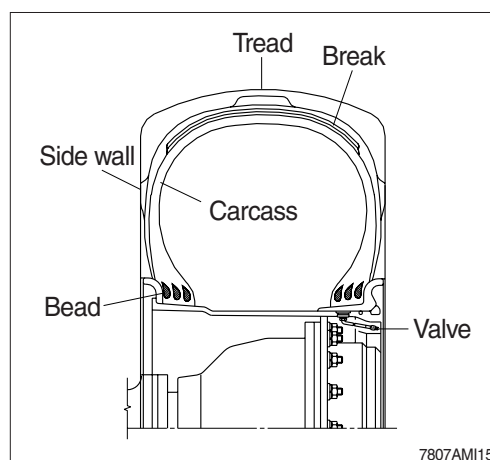

(2) Separation of tire

- ① After moving the machine to flat ground, lower the bucket to the ground and turn the parking brake switch ON.

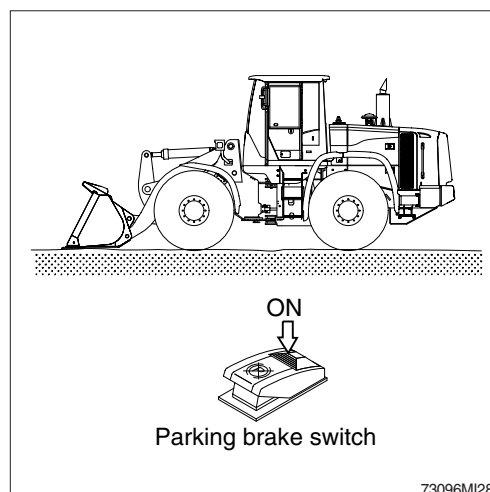

- ② Loosen slightly all wheel mounting.
 - Tools : Socket 32 mm
 - Torque wrench
 - Extension bar
- ③ Lift the machine with a jack.
- ④ Loosen all wheel mounting nuts and replace the tire.

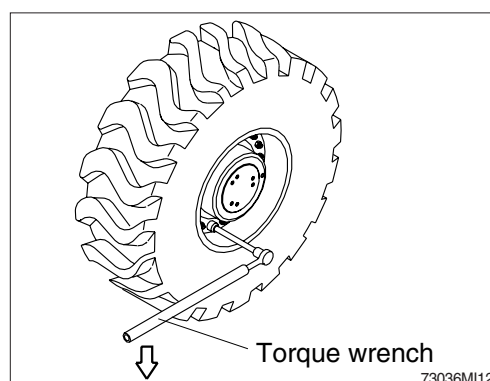

(3) Direction of tire to be installed

- ① Be careful that the valve should be facing the outside.

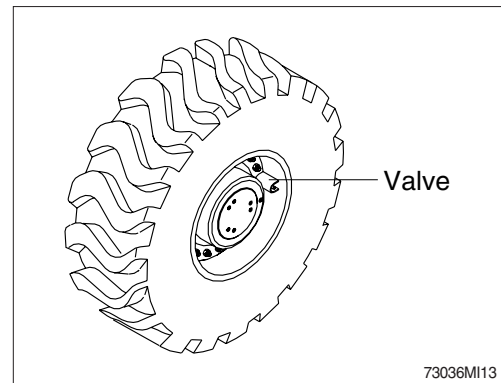

(4) Mounting of tire

- ① Lightly tighten nuts as shown in the illustration.
- ② Lower the jack after tire is replaced.
- ③ Tighten nuts according to the specified tighten torque.
 - Tightening torque : $79 \pm 2.5 \text{ kgf} \cdot \text{m}$
($571 \pm 18 \text{ lbf} \cdot \text{ft}$)

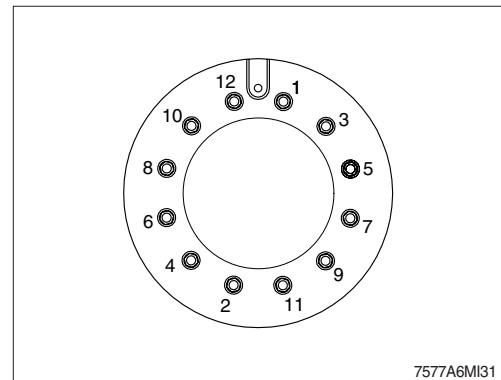

26) STORING TIRES AFTER REMOVAL

As a basic rule, store the tires in a warehouse which unauthorized persons cannot enter. If the tire are stored outside, always erect a fence around the tires and put up "No Entry" and other warning signs that even young children can understand.

Stand the tire on level ground, and block it securely so that it cannot roll or fall over.

If the tire should fall over, get out of the way quickly. The tires for construction equipment are extremely heavy, so trying to hold the tire may lead to serious injury.

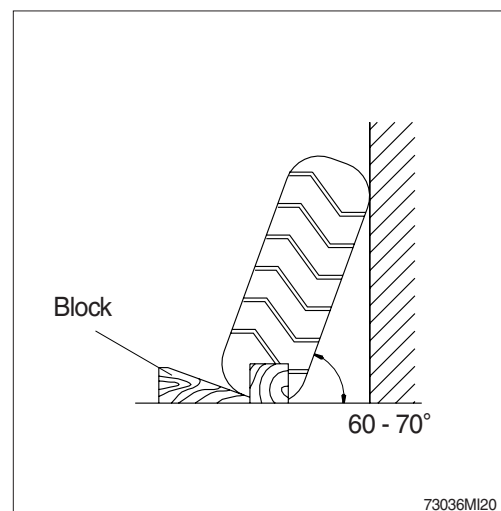

27) CHECK TRANSMISSION OIL LEVEL

The oil level check must be carried out as follows;

- (1) Oil level check (weekly).
- (2) At horizontally standing machine.
- (3) Transmission in neutral position.
- (4) In cold start phase, the engine must be running about 2~3 minutes at idling speed, and the marking on the oil level gauge must then be lying above the cold start mark blue.
- (5) At operating temperature of the transmission (about 80~90°C).
- (6) At engine idling speed.
- (7) On the oil level gauge, the oil level must be lying in the zone HOT.

▲ When checking, press the parking brake switch and fix the front and rear frames with the safety lock bar.

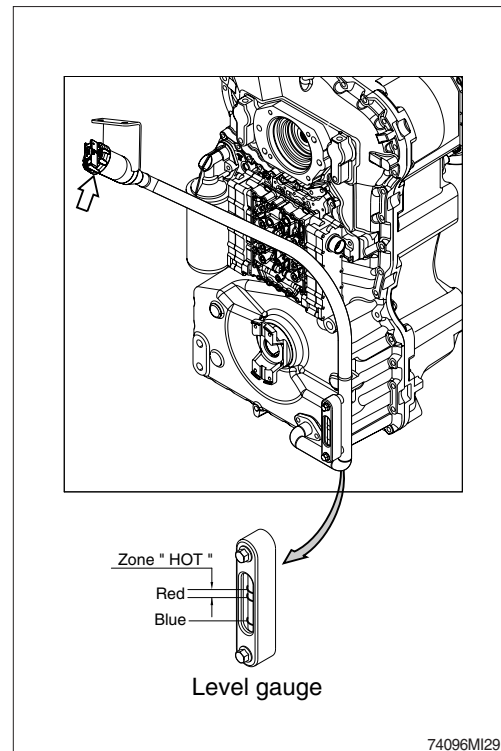

28) REPLACEMENT OF TRANSMISSION OIL AND FILTER ELEMENT

- (1) Operate the machine for a few minutes in order to warm the transmission oil.
- (2) Move the machine to flat ground. Lower the bucket to the ground and slightly apply downward force.
- (3) Press the parking brake switch and stop the engine.
- (4) Open transmission air breather to relieve internal air pressure.
- (5) Remove the transmission drain plug. Allow the transmission oil to drain into a suitable container.

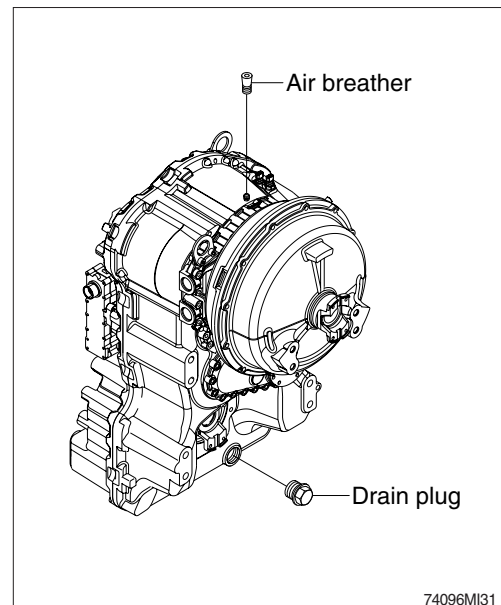

- (6) Remove the transmission oil filter cartridge.
Dispose of the used transmission oil filter cartridge properly.
- (7) Clean the filter cartridge mounting base.
Remove any part of the filter cartridge gasket that remains on the filter cartridge mounting base.

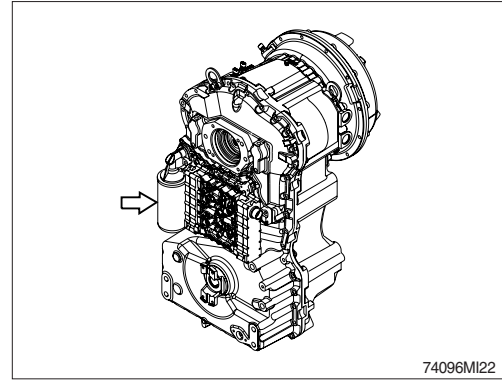

- (8) Apply a light coat of oil to the gasket of a new transmission oil filter cartridge.
- (9) Install the new transmission oil filter cartridge.
Screw the filter in until contacts with the sealing surface is obtained and tighten it now by hand about 1/3 to 1/2 turn.

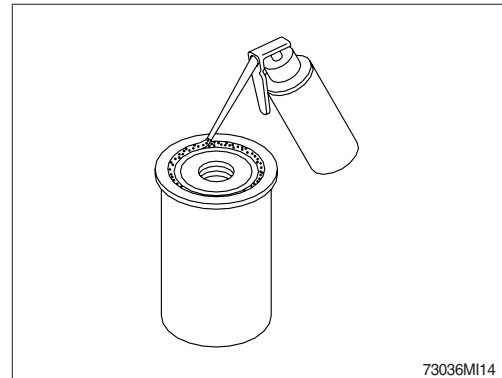

- (10) Fill the oil through level gauge inlet and check if the oil is at the appropriate level.
- (11) The proper oil amount is 20 liters. (5.3 U.S. gallons)

- ▲ As the machine is hot after operation wait until the temperature has dropped.
- ▲ It is imperative to pay attention to absolute cleanliness of oil and filter.
Binding is in any case the marking on the oil level gauge.

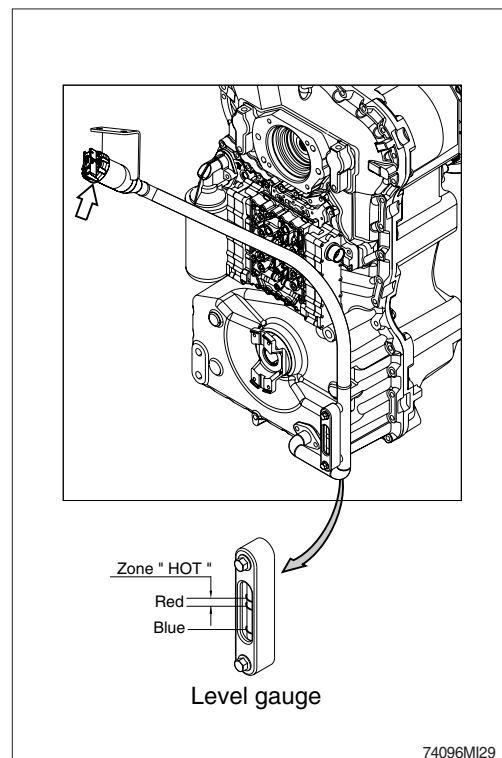

29) CLEANING TRANSMISSION AIR BREATHER

- (1) Remove dust or debris around the air breather.
- (2) Remove the air breather and wash it with cleaning oil.

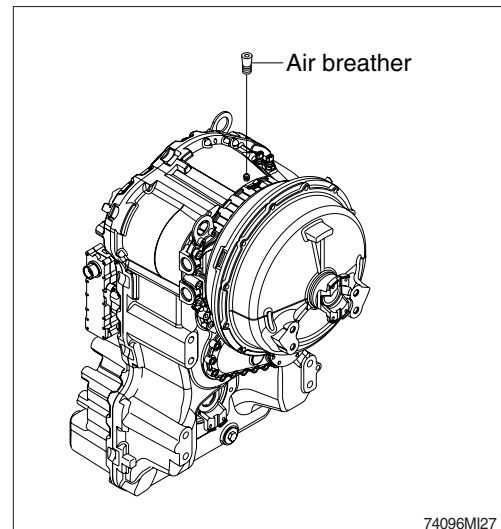

30) CHECK AND SUPPLYING AXLE OIL

- (1) Move the machine to flat ground.
- (2) Open the axle air breather to relieve internal air pressure.

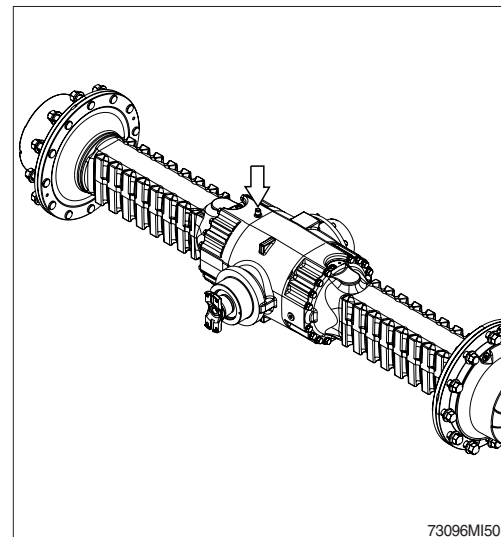

- (3) Remove the plug and check the oil amount.
If the oil level is at the hole of the plug, it is normal.

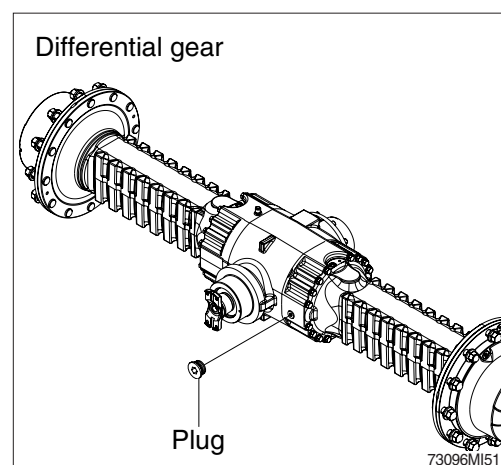

(4) If the oil level is below the plug hole, supply oil through a plug hole.

▲ When checking the oil level, press the parking brake switch and fix front and rear frames using the safety lock bar.

▲ As the machine is hot after operation, wait until the temperature has dropped.

※ Set the plug of planetary gear in parallel to the ground.

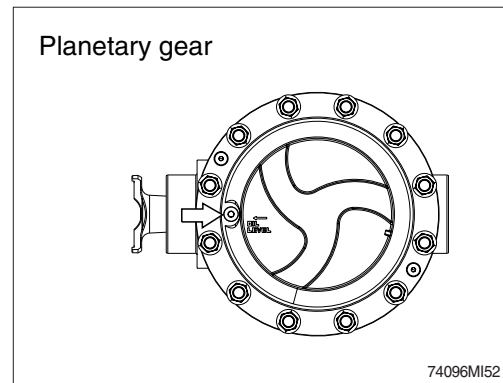

31) CHANGE THE AXLE OIL

(1) Place a case under drain plug to catch oil.

(2) Remove the air breather to relieve internal pressure.

(3) Drain oil the differential gear.

① Remove the refilling plug and remove the drain plug to drain oil off.

② Wash drain plug and install it.

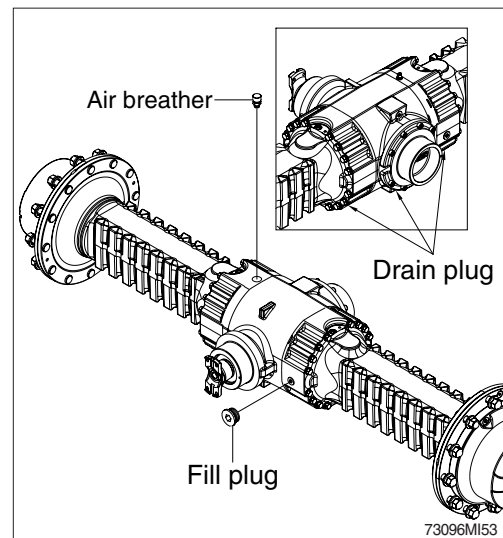

(4) Drain oil planetary gear.

① Drain oil by removing drain plug.

※ The drain plug should be facing the ground.

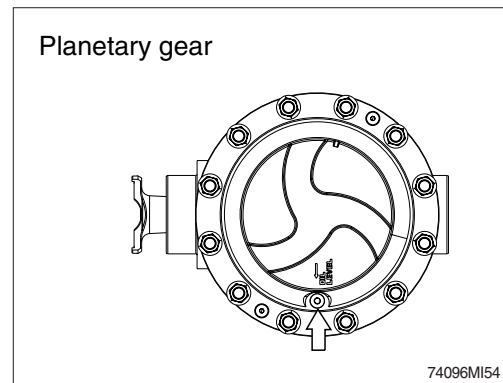

(5) After draining, put the drain plug of planetary gear in parallel to the ground.

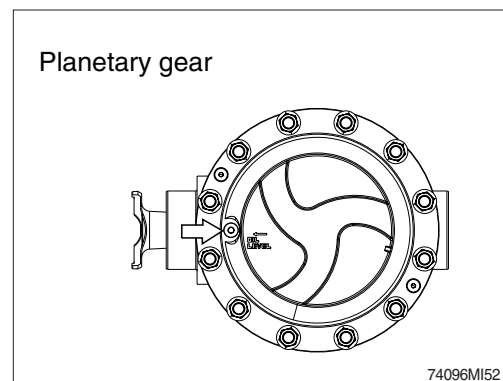

(6) Supply oil into the differential gear and the planetary gear.

·Oil amount

Front axle : 17.7 l (4.7 U.S. gal)

Rear axle : 17.7 l (4.7 U.S. gal)

(7) Supply oil until it overflows from the oil filler, then install the plug.

▲ As the machine is hot after operation, wait until the temperature has dropped.

If a work requires frequent use of brake, replace it earlier than normal change interval.

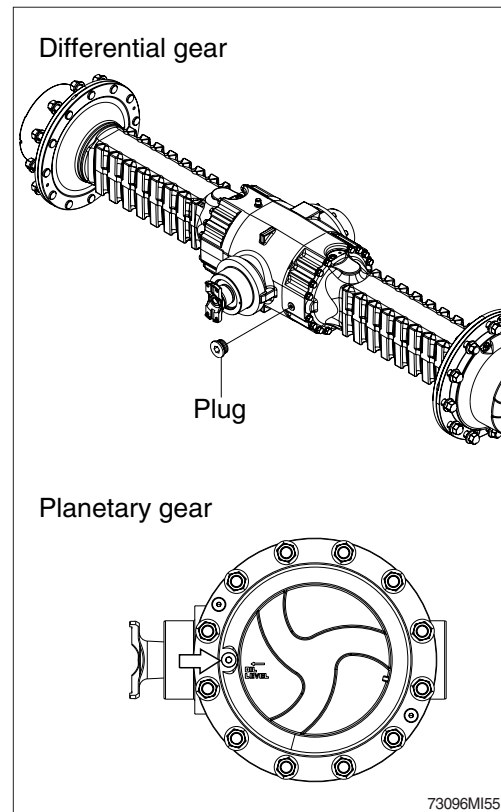

32) CLEANING AXLE BREATHER

(1) Remove dust or debris around the breather.

(2) Remove the breather and wash it with cleaning oil.

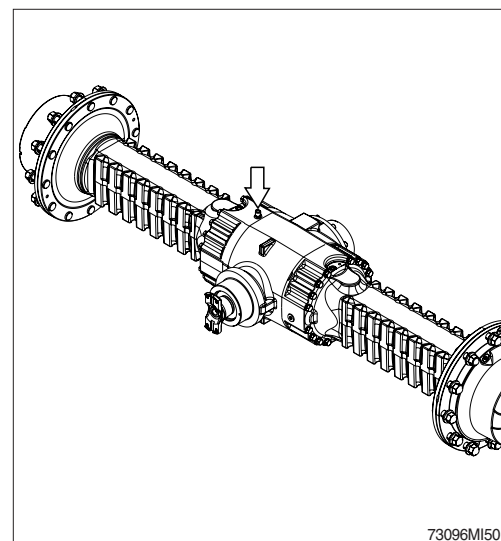

33) LUBRICATION

(1) Supply grease through the grease nipple, using grease gun.

(2) After lubricating, clean off spilled grease.

▲ Press the parking brake switch and fix front and rear frames using the safety lock bar.

▲ Set the work equipment in a stable position and turn the hydraulic safety lock valve into the lock position.

(3) Rear axle pivot : 2EA

(4) Steering cylinder pin : 4EA

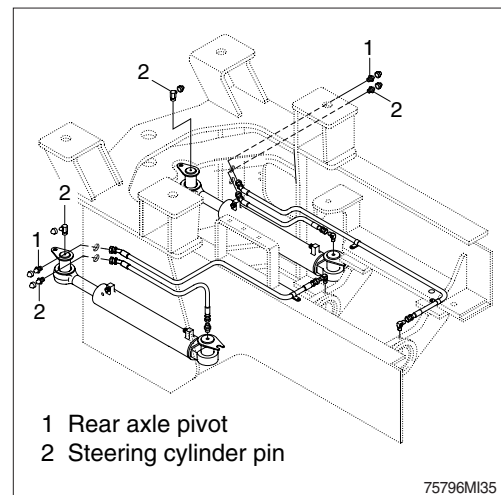
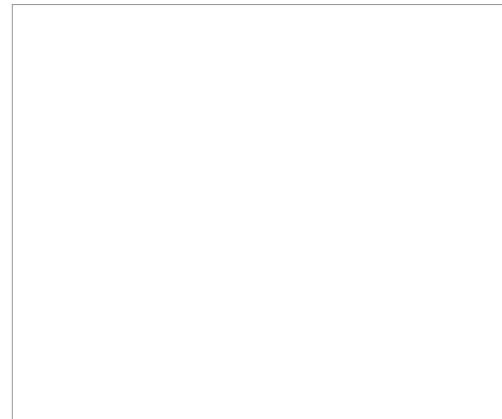

(5) Center pivot pin : 2EA

(6) Drive shaft

- Front (flange bearing) : 1EA

- Center (slip yoke) : 2EA

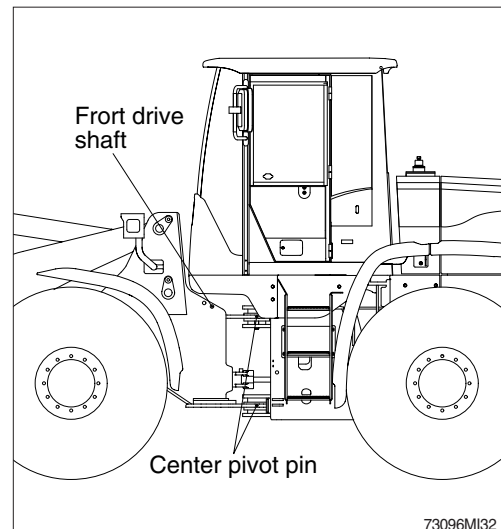

34) REPLACEMENT OF BOLT ON CUTTING EDGE

(1) Replacement time

Replace the cutting edge before it has worn out to the end of bucket.

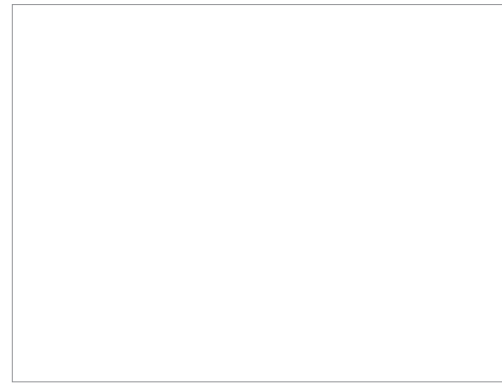

(2) Replacement method

▲ Make sure the work equipment does not move when replacing the cutting edge.

Set the work equipment in a stable position, put the hydraulic safety lock lever in the LOCK position and stop the engine.

- ① Lift the bucket to a proper height and insert blocks so that the bucket does not fall down.
- ② Loosen bolts and nuts, and remove the cutting edge.
- ③ Clean the contacted surface.
- ④ Turn the cutting edge and install on the bucket.
- ※ **If both sides have worn out, replace it with new ones.**
- ※ **If the contacted face of cutting edge has worn out, repair the contacted face of it.**
- ⑤ Tighten evenly bolts and nuts to remove the clearance between bucket and cutting edge.
 - Tightening torque : $62.8 \pm 9.4 \text{ kgf} \cdot \text{m}$
($454 \pm 68 \text{ lbf} \cdot \text{ft}$)
- ⑥ After a few hours of operation, retighten bolts.

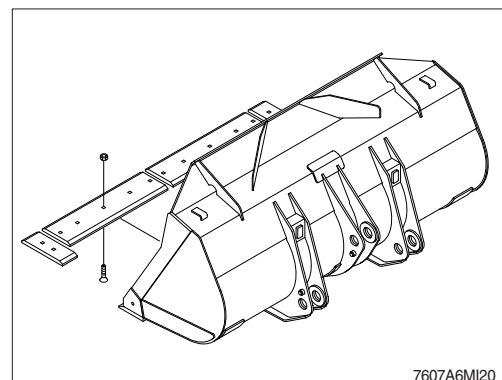
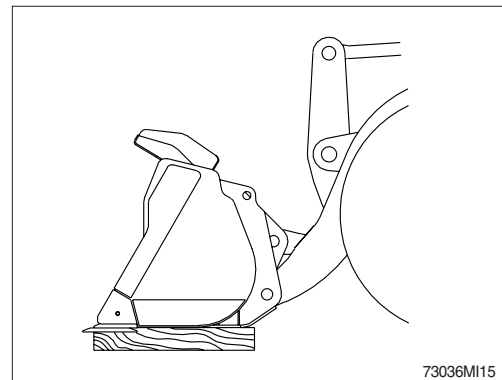

35) REPLACEMENT OF BUCKET TOOTH

(1) Replacement time

Replace the bucket tooth before it has worn out to the end of the bucket.

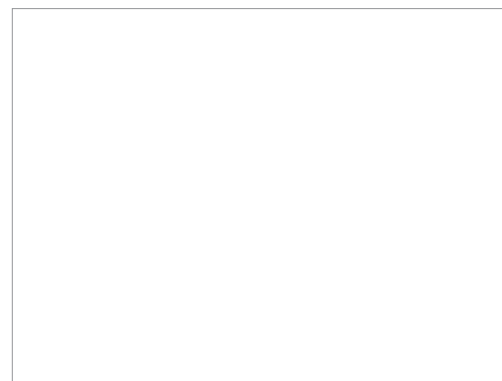

(2) Replacement method

▲ **Make sure the work equipment does not move when replacing the bucket tooth.**

Set the work equipment in a stable position, put the pilot cut off switch in the OFF position and stop the engine.

- ① Lift the bucket to a proper height and insert blocks so that the bucket does not fall down.
- ② Loosen bolts and nuts, and remove bucket tooth.
- ③ Clean the contacted surface.
- ※ **If the contacted face of bucket tooth has worn out, repair the contacted face of it.**
- ④ Install new bucket tooth on the bucket, and tighten bolts and nuts.
 - Tightening torque : $62.8 \pm 9.4 \text{ kgf} \cdot \text{m}$
($454 \pm 68 \text{ lbf} \cdot \text{ft}$)
- ⑤ After a few hours of operation, retighten bolts.

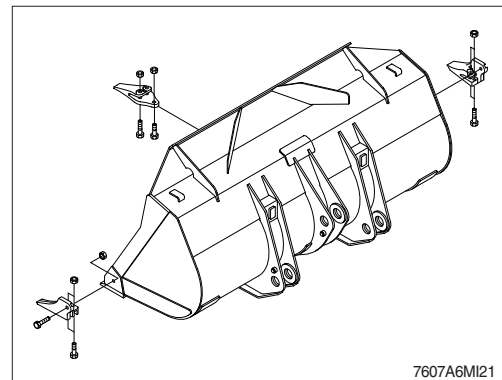
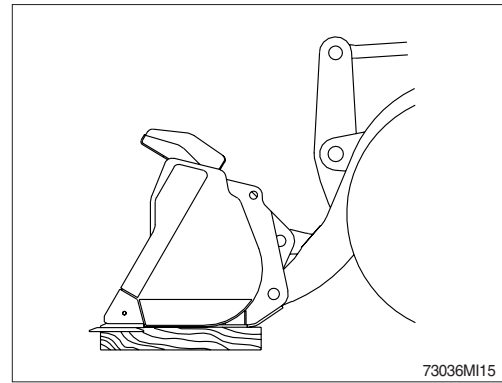

36) MAINTENANCE OF WORK EQUIPMENT

- (1) Lubricate to each pin of working device.
Lubricate the grease to grease nipple in accordance with lubrication intervals.

No.	Description	Qty
1	Bucket cylinder-front frame connection pin	1
2	Boom cylinder-front frame connection pin	2
3	Boom cylinder-boom connection pin	2
4	Bell crank-bucket link connection pin	1
5	Bucket-boom connection pin	2
6	Bucket-bucket link connection pin	1
7	Boom-bell crank connection pin	1
8	Bucket cylinder-bell crank connection pin	1
9	Boom-front frame connection pin	2

- ※ Shorten lubricating interval when working in the water or dusty place.

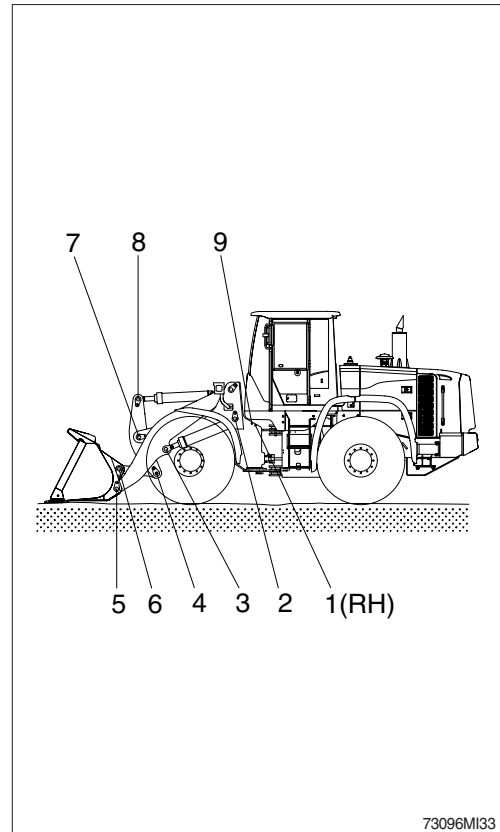

- (2) Check for wear and tear of work equipment pins and bushings.
(3) Check for damage of boom and bell crank.

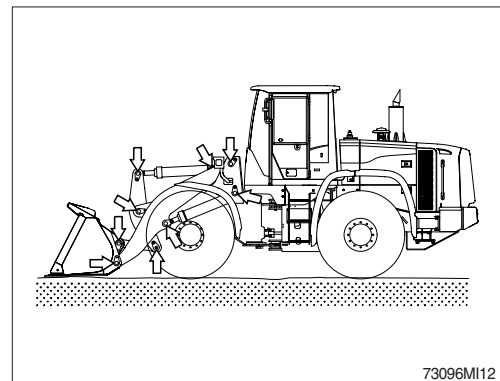

- (4) Dust seal are mounted on the rotating part of working device to extend the lubricating interval.
- ※ Mount the lip to be faced out side when replace the dust seal.
 - ※ If it is assembled in wrong direction, it will cause fast wear of pin and bushing, and create noise and vibration during operation.
 - ※ Make sure the seals are not damaged or deformed.

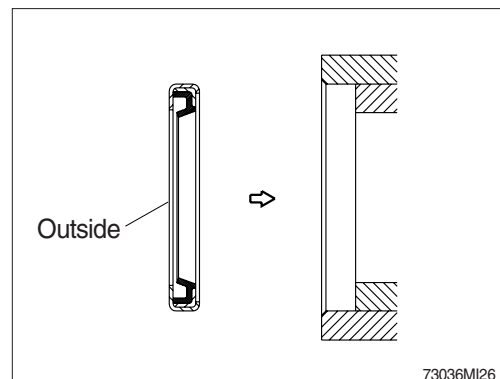

37) WORK EQUIPMENT SUPPORT

When carrying out inspection and maintenance with the equipment raised, fit a stand under the lift arm securely to prevent the work equipment from coming down. In addition, set the work equipment control levers to the Hold position and Lock with the safety lock.

